

Zubehör für die Hochfrequenzchirurgie
Accessories for electrosurgery
Accesorios para la electrocirugía
Accessoires électrochirurgicaux
Accessori per elettrochirurgia

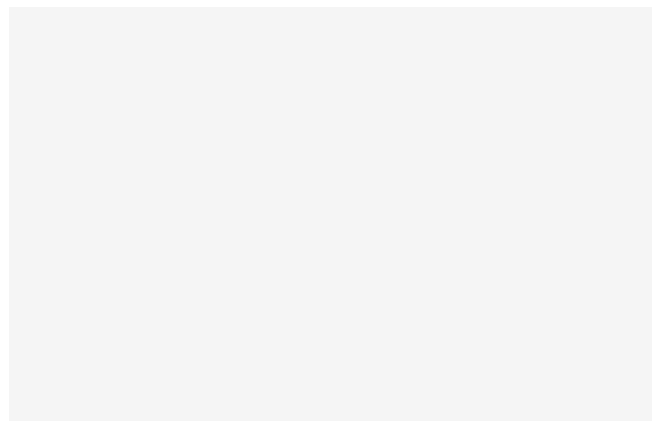











Überreicht durch
With compliments
Atentamente
Avec les compliments de
Con i complimenti









Surgical Innovation is our Passion

Inhalt
Index
Indice
Index
Indice

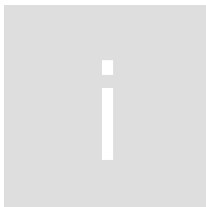

1 7-22		Monopolare Elektroden-Handgriffe Monopolar electrode handles Mangos porta-electrodos monopolares Manches porte-électrodes monopolaires Manici portaelettrodi monopolari
2 25-47		Monopolare Elektroden Monopolar electrodes Electrodos monopolares Electrodes monopolaires Elettrodi monopolari
3 49-56		Neutralelektroden Neutral electrodes Placas neutras Electrodes neutres Elettrodi neutri
4 57-85		Bipolares Instrumentarium Bipolar instruments Instrumentos bipolares Instruments bipolaires Strumenti bipolari
5 87-103		Instrumentarium zur bipolaren Gefäßversiegelung Instruments for bipolar vessel sealing Instrumentos para el sellado vascular bipolar Instruments pour la clampage vasculaire bipolaire Strumenti di sigillatura vascolare bipolare
6 105-121		Anschlusskabel sowie Adapter Connecting cables and adapters Cables de conexión así como adaptadores Câbles de raccordement et adaptateurs Cavi di collegamento e adattatori
7 123-137		Argon-Beamer-System Argon Beamer System Sistema Argon Beamer Système Argon Beamer Sistema Argon Beamer
8 139-149		Rauchgasabsaugung und Zubehör Smoke evacuator and accessories Evacuación de gases de combustión y accesorios Évacuateur de fumée et accessoires Aspiratore di fumo e accessori

9 151-153		Nervstimulator Nerve stimulator Estimulador de nervios Neurostimulateur Neurostimolatore
10 155-166		Übersicht der Hochfrequenzchirurgie-Geräte Overview of electrosurgery units Resumen de aparatos electroquirúrgicos Résumé des bistouris électrochirurgicaux Elenco degli apparecchi elettrochirurgici
11 167-177		Fußschalter Foot switches Interruptores de pie Interrupteurs à pédale Interruttori a pedale
12 179-180		Netzkabel Mains cables Cables de conexión a la red Câbles d'alimentation Cavi d'alimentazione
13 181-187		Fahrgestelle Trolleys Soportes móviles Chariots Carrelli
14 189-215		Zubehörsätze Accessory sets Juegos de accesorios Jeux d'accessoires Serie di accessori
15 217-221		Nummern-Index Index of order numbers Índice de números de referencia Index numérique des références de commande Elenco dei codici

1

Monopolare Elektroden-Handgriffe
Monopolar electrode handles
Mangos porta-electrodos monopolares
Manches porte-électrodes monopolaires
Manici portaelettrodi monopolari

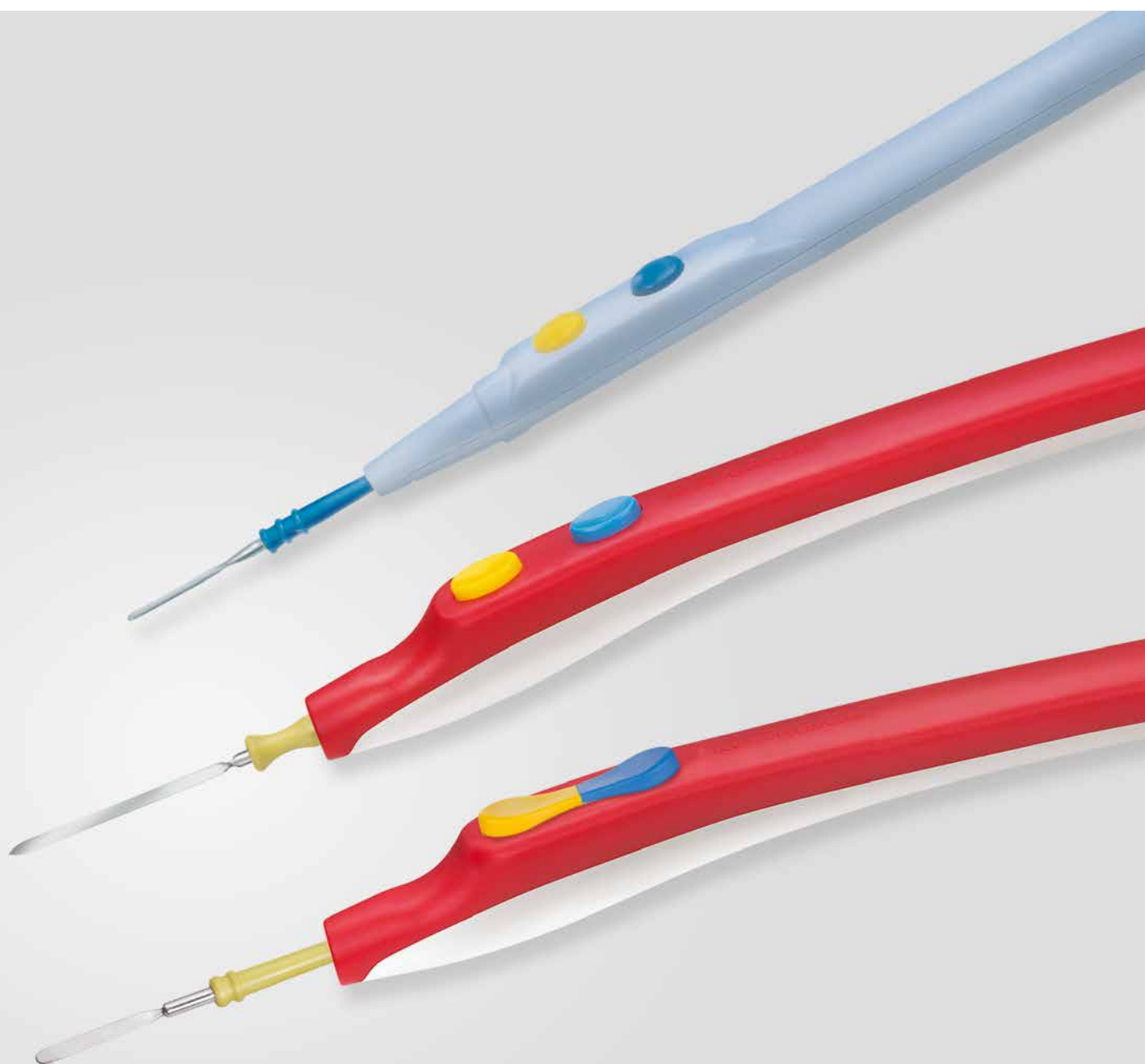

Die neuen monopolaren Elektroden-Handgriffe.
Touch and feel the difference!

The new monopolar electrode handles.
Touch and feel the difference!

Los nuevos mangos de electrodos monopolares.
Toquelos y sienta la diferencia!

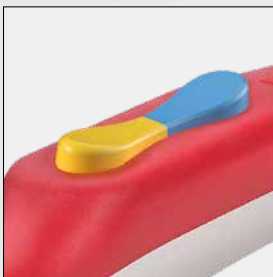

Aktivierung von Cut und Coag
Cut and Coag activated
Activación de Cut y Koag
Activation Coupe et Coag
Attivazione di Cut e Koag

Hochwertige Materialien
Premium quality materials
Materiales de primera calidad
Matériaux de haute qualité
Materiali di alta qualità

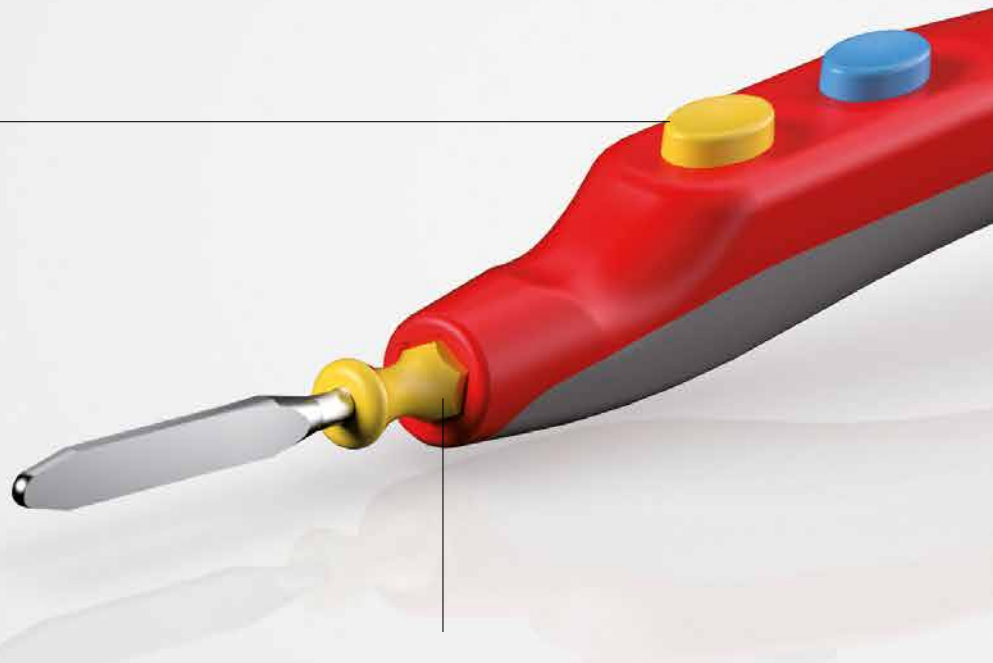

Die Öffnungen sind Bestandteil des Reinigungskonzeptes und stellen sicher, dass kleinste Mengen an Flüssigkeit während des Reinigungsprozesses wieder abfließen können.

The openings are part of the cleaning concept and ensure that the smallest amounts of liquid can be drained off during the cleaning process.

Las orificios son parte del concepto de limpieza y aseguran que las cantidades más pequeñas de líquido pueden ser drenadas de nuevo durante el proceso de limpieza.

Les ouvertures font partie du concept de nettoyage et s'assurent que les plus petites quantités de liquide peuvent être drainées pendant le processus de nettoyage.

Le aperture fanno parte del concetto di pulizia ed assicurano che le più piccole quantità di liquido possano essere scolate indietro durante il processo di pulizia.

Elektrodenaufnahme für Elektroden
Electrode connection for electrodes
Soporte de electrodos
Orifice d'insertion de l'électrode
Portaelettrodi
Ø 4,0, 2,4, 1,6 mm

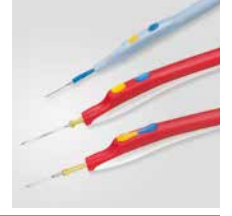

Les nouveaux manches d'électrodes monopolaires.
Touchez et ressentez la différence!

I nuovi manici monopolari per elettrodi.
Provate la differenza!

1

Knickschutz
Anti-kink grommet
Protección contra doblamiento
Protection anti-torsion
Guaina di protezione

Hochwertiges Kabel, 4 m
Premium quality cord, 4 m
Cable de primera calidad, 4 m
Câble de haute qualité, 4 m
Cavo di alta qualità, 4 m

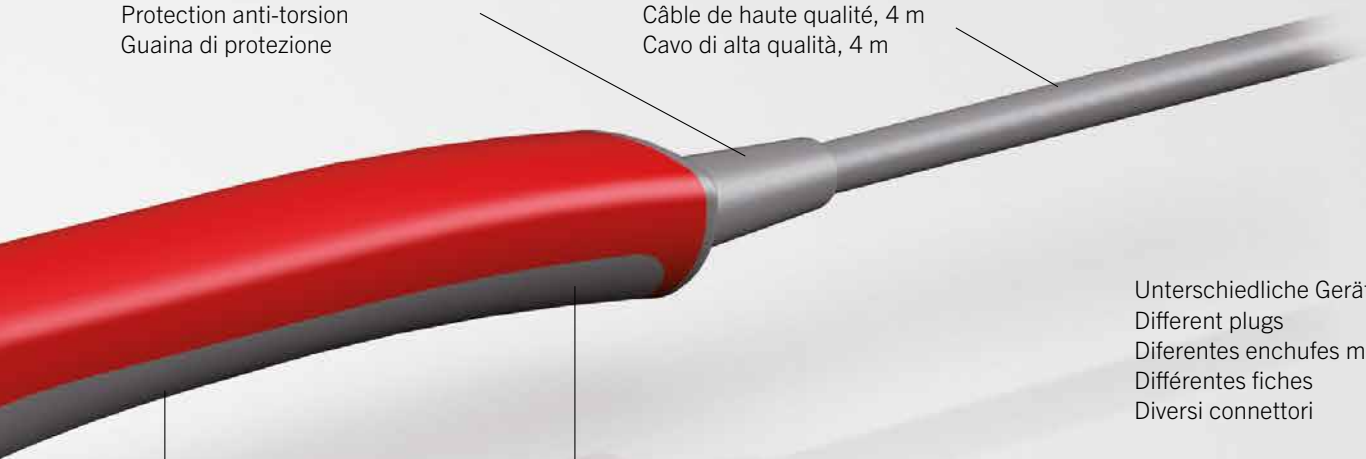

Unterschiedliche Gerätestecker
Different plugs
Diferentes enchufes macho
Différentes fiches
Diversi connettori

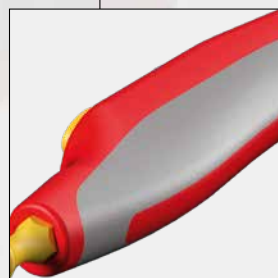

Ergonomisch tailliert
Ergonomically tailored
Ergonómico y entallado
Profil ergonomique
Linea ergonomica

Hochwertige Weichteilkomponente
Premium quality pliant component
Componente de material blando
de primera calidad
Partie souple de grande qualité
Componenti per tessuti molli
di alta qualità

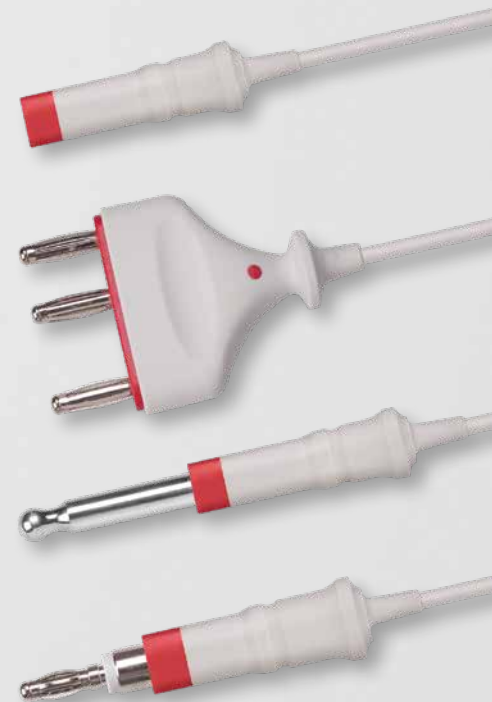

Monopolare Elektroden-Handgriffe
Monopolar electrode handles
Mangos porta-electrodos monopolares
Manches porte-électrodes monopolaires
Manici portaelettrodi monopolari

smartPen

Passend für **maXium®/ME 411/ME 401/ME 400/ME 200**
Suitable for **ME MB 3/ME MB 2/ME MB 1/ME M1/ME 102**
Para
Pour
Per

Ø 4 mm



80-217-13-04 *max. 6300 V_p*

KLS Martin

Elektroden-Handgriff mit zwei Tasten, großem Koax-Stecker und fest angeschlossenem 4 m Kabel
Electrode handle with two pushbuttons, large coax plug and permanent cord of 4 m
Mango porta-electrodos con dos teclas, clavija coaxial grande y cable de conexión fija de 4 m
Manche porte-électrode avec interrupteur digital double, grande fiche coax et câble de raccordement fixe de 4 m
Manico portaelettrodi con due tasti, spina coassiale grande e cavo di connessione fisso da 4 m

Ø 4 mm



80-210-13-04 *max. 6300 V_p*

KLS Martin/Erbe intern. Version/Valleylab

Elektroden-Handgriff mit zwei Tasten, 3-Pin-Stecker und fest angeschlossenem 4 m Kabel
Electrode handle with two pushbuttons, 3-pin plug and permanent cord of 4 m
Mango porta-electrodos con dos teclas, clavija de 3 patillas y cable de conexión fija de 4 m
Manche porte-électrode avec interrupteur digital double, fiche à 3 broches et câble de raccordement fixe de 4 m
Manico portaelettrodi con due tasti, spina a 3-spire e cavo di connessione fisso da 4 m

Ø 4 mm



80-210-18-04 *max. 6300 V_p*

maXium® e/Erbe ICC/ACC/VIO

Elektroden-Handgriff mit zwei Tasten, mit 5-mm-Stecker und fest angeschlossenem 4 m Kabel
Electrode handle with two pushbuttons, with 5-mm plug and permanent cord of 4 m
Mango porta-electrodos con dos teclas, con clavija de 5 mm y cable de conexión fija de 4 m
Manche porte-électrode avec interrupteur digital double, avec fiche de 5 mm et câble de raccordement fixe de 4 m
Manico portaelettrodi con due tasti, con spina da 5 mm e cavo di connessione fisso da 4 m

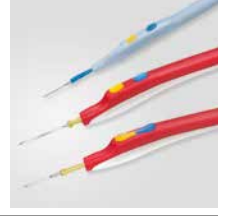

Ø 4 mm



80-220-02-04 *max. 6300 V_p*

KLS Martin

Elektroden-Handgriff ohne Tasten, großem Koax-Stecker und fest angeschlossenem 4 m Kabel
 Electrode handle without pushbuttons, large coax plug and permanent cord of 4 m
 Mango porta-electrodos sin teclas, clavija coaxial grande y cable de conexión fija de 4 m
 Manche porte-électrode sans interrupteur, grande fiche coax et câble de raccordement fixe de 4 m
 Manico portaelettrodi senza tasti, spina coassiale grande e cavo di connessione fisso da 4 m

Ø 4 mm



80-220-41-04 *max. 6300 V_p*

maXium® i/ME MB 3 i/Valleylab/Bovie

Elektroden-Handgriff ohne Tasten, mit 8-mm-Stecker und fest angeschlossenem 4 m Kabel für Valleylab-Geräte
 Electrode handle without pushbuttons, with 8-mm plug and permanent cord of 4 m, for Valleylab units
 Mango porta-electrodos sin teclas, con clavija de 8 mm y cable de conexión fija de 4 m para aparatos Valleylab
 Manche porte-électrode sans interrupteur, avec fiche de 8 mm et câble de raccordement fixe de 4 m pour appareils Valleylab
 Manico portaelettrodi senza tasti, con spina da 8 mm e cavo di connessione fisso da 4 m per apparecchi Valleylab

Ø 4 mm



80-220-31-04 *max. 6600 V_p*

maXium® e/Erbe ICC/ACC/VIO

Elektroden-Handgriff ohne Tasten, mit 5-mm-Stecker und fest angeschlossenem 4 m Kabel
 Electrode handle without pushbuttons, with 5-mm plug and permanent cord of 4 m
 Mango porta-electrodos sin teclas, con clavija de 5 mm y cable de conexión fija de 4 m
 Manche porte-électrode sans interrupteur, avec fiche de 5 mm et câble de raccordement fixe de 4 m
 Manico portaelettrodi senza tasti, con spina da 5 mm e cavo di connessione fisso da 4 m

Monopolare Elektroden-Handgriffe
 Monopolar electrode handles
 Mangos porta-electrodos monopolares
 Manches porte-électrodes monopolaires
 Manici portaelettrodi monopolari

smartPen

Passend für **maXium®/ME 411/ME 401/ME 400/ME 200**
 Suitable for **ME MB 3/ME MB 2/ME MB 1/ME M1/ME 102**
 Para
 Pour
 Per

Ø 2,4 mm



80-210-21-04 *max. 6300 V_p*

KLS Martin/Erbe intern. Version/Valleylab

Elektroden-Handgriff mit zwei Tasten, 3-Pin-Stecker und fest angeschlossenem 4 m Kabel
 Electrode handle with two pushbuttons, 3-pin plug and permanent cord of 4 m
 Mango porta-electrodos con dos teclas, clavija de 3 patillas y cable de conexión fija de 4 m
 Manche porte-électrode avec interrupteur digital double, fiche à 3 broches et câble de raccordement fixe de 4 m
 Manico portaelettrodi con due tasti, spina a 3-spire e cavo di connessione fisso da 4 m

Ø 2,4 mm



80-210-23-04 *max. 6300 V_p*

KLS Martin/Erbe intern. Version/Valleylab

Elektroden-Handgriff mit Wippschalter, 3-Pin-Stecker und fest angeschlossenem 4 m Kabel
 Electrode handle with rocker switch, 3-pin plug and permanent cord of 4 m
 Mango porta-electrodos con interruptor basculante, clavija de 3 patillas y cable de conexión fija de 4 m
 Manche porte-électrode avec interrupteur à bascule, fiche à 3 broches et câble de raccordement fixe de 4 m
 Manico portaelettrodi con selettore a levetta, spina a 3-spire e cavo di connessione fisso da 4 m

Ø 4 mm



80-227-00-04 *max. 6300 V_p*

KLS Martin

Elektroden-Handgriff mit zwei Tasten und abnehmbarem Kabel
 Electrode handle with two pushbuttons and with detachable cord
 Mango porta-electrodos con dos teclas y mangos de electrodos con cable desmontable
 Manche porte-électrode avec interrupteur digital double et avec câble amovible
 Manico portaelettrodi con due tasti e con cavo rimovibile

80-227-01-04 *max. 6300 V_p*

KLS Martin

Anschlusskabel (inklusive Kabel)
 Connection cord (including cord)
 Cable de conexión (inclusive cable)
 Câble de raccordement (avec câble)
 Cavo di collegamento (cavo incluso)



80-227-02-04 *max. 6300 V_p*

Erbe VIO, ICC, ACC

Anschlusskabel (inklusive Kabel)
 Connection cord (including cord)
 Cable de conexión (inclusive cable)
 Câble de raccordement (avec câble)
 Cavo di collegamento (cavo incluso)

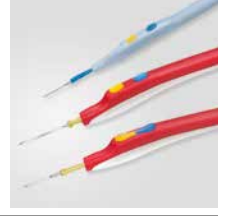

Passend für MD 62/ME K1/ME K2/ME K3/ME 82/miniCutter

Suitable for
 Para
 Pour
 Per

Ø 4 mm



80-217-05-04 max. 6300 V_p

KLS Martin

Elektroden-Handgriff mit einer Taste, großem Koax-Stecker und fest angeschlossenem 4 m Kabel
 Electrode handle with a pushbutton, large coax plug and permanent cord of 4 m
 Mango porta-electrodos con una tecla, clavija coaxial grande y cable de conexión fija de 4 m
 Manche porte-électrode avec un interrupteur digital, grande fiche coax et câble de raccordement fixe de 4 m
 Manico portaelettrodi con un tasto, spina coassiale grande e cavo di connessione fisso da 4 m

Ø 1,6 mm



80-214-13-04 max. 6300 V_p

KLS Martin

Dental-Elektroden-Handgriff mit einer Taste, großem Koax-Stecker und fest angeschlossenem 4 m Kabel
 Dental electrode handle with a pushbutton, large coax plug and permanent cord of 4 m
 Mango porta-electrodos dental con una tecla, clavija coaxial grande y cable de conexión fija de 4 m
 Manche porte-électrode dentaire avec un interrupteur digital, grande fiche coax et câble de raccordement fixe de 4 m
 Manico portaelettrodi dentale con un tasto, spina coassiale grande e cavo di connessione fisso da 4 m

Ø 1,6 mm



80-214-12-04 max. 6300 V_p

KLS Martin

Dental-Elektroden-Handgriff ohne Taste, großem Koax-Stecker und fest angeschlossenem 4 m Kabel
 Dental electrode handle without pushbutton, large coax plug and permanent cord of 4 m
 Mango porta-electrodos dental sin tecla, clavija coaxial grande y cable de conexión fija de 4 m
 Manche porte-électrode dentaire sans interrupteur digital, grande fiche coax et câble de raccordement fixe de 4 m
 Manico portaelettrodi dentale senza tasto, spina coassiale grande e cavo di connessione fisso da 4 m

Handgriffe · Handles · Mangos · Manches · Manici

	80-217-13-04	80-210-13-04	80-210-18-04	80-217-05-04	80-220-02-04	80-220-41-04	80-220-31-04	80-227-00-04 & 80-227-01-04	80-227-00-04 & 80-227-02-04
Ø (mm)	4,0	4,0	4,0	4,0	4,0	4,0	4,0	4,0	4,0
Gerätetyp Type of unit Tipo del aparato Type d'appareil Tipo d'apparecchio									
maXium® m	x	x			x*			x	
maXium® i		x				x*			
maXium® e		x	x				x*		x
maXium® smart C m	x	x			x*			x	
maXium® smart C i		x				x*			
maXium® smart C e		x	x				x*		x
ME 411	x	x			x*			x	
ME 401	x	x			x*			x	
ME 400	x	x			x*			x	
ME 200	x	x			x*			x	
ME MB 1	x	x			x*			x	
ME M 1	x	x			x*			x	
ME MB 2	x	x			x*			x	
ME MB 3	x	x			x*	x*		x	
ME 81	x	x			x*			x	
ME 82	x	x		x	x*			x	
miniCutter				x	x*				
ME 102	x	x			x*			x	
ME 80	x	x			x*			x	
ME 50	x	x			x*			x	
ME K1				x	x*				
ME K2				x	x*				
ME 60				x	x*				
MD 70				x	x*				
MD 62				x	x*				

x* = bei Verwendung eines Fußschalters
 for use with foot switch
 usando un interruptor de pie
 pour utilisation avec un interrupteur à pédale
 per l'uso di un interruttore a pedale

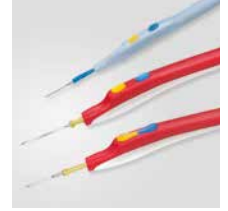

	80-210-21-04	80-210-23-04	80-214-13-04	80-214-12-04
Ø (mm)	2,4	2,4	1,6	1,6
Gerätetyp Type of unit Tipo del aparato Type d'appareil Tipo d'apparecchio				
maXium® m	x	x	x	x*
maXium® i	x	x		
maXium® e	x	x		
maXium® smart C m	x	x	x	x*
maXium® smart C i	x	x		
maXium® smart C e	x	x		
ME 411	x	x	x	x*
ME 401	x	x	x	x*
ME 400	x	x	x	x*
ME 200	x	x	x	x*
ME MB 1	x	x	x	x*
ME M 1	x	x	x	x*
ME MB 2	x	x	x	x*
ME MB 3	x	x	x	x*
ME 81	x	x	x	x*
ME 82	x	x	x	x*
miniCutter			x	x*
ME 102	x	x	x	x*
ME 80	x	x	x	x*
ME 50	x	x	x	x*
ME K1				
ME K2				
ME 60			x	x*
MD 70			x	x*
MD 62			x	x*

x* = bei Verwendung eines Fußschalters
 for use with foot switch
 usando un interruptor de pie
 pour utilisation avec un interrupteur à pédale
 per l'uso di un interruttore a pedale

Monopolare Elektroden-Handgriffe
Monopolar electrode handles
Mangos porta-electrodos monopolares
Manches porte-électrodes monopolaires
Manici portaelettrodi monopolari

Passend für **maXium®/ME 411/ME 401/ME 400/ME 200**
Suitable for **ME MB 3/ME MB 2/ME MB 1/ME M1/ME 102**
Para
Pour
Per

Ø 4 mm

1/2



1/3



Ø 12,5 mm

80-220-00-04 *max. 3000 V_p*

KLS Martin/Aesculap/Berchtold

Elektroden-Handgriff ohne Tasten, mit großem Koax-Stecker und 4 m Anschlusskabel
Electrode handle without pushbuttons, with large coax plug and connection cable of 4 m
Mango porta-electrodos sin teclas con clavija coaxial y cable de conexión de 4 m
Manche porte-électrode sans interrupteur, avec grande fiche coax et câble de raccordement de 4 m
Manico portaelettrodi senza tasti, con spina coassiale grande e cavo di connessione da 4 m

Ø 4 mm

1/2



1/3



Ø 12,5 mm

80-217-02-04 *max. 5500 V_p*

KLS Martin/Aesculap/Berchtold

Elektroden-Handgriff mit zwei Tasten, großem Koax-Stecker und 4 m Anschlusskabel
Electrode handle with two pushbuttons, large coax plug and connection cable of 4 m
Mango porta-electrodos con dos teclas, clavija coaxial grande y cable de conexión de 4 m
Manche porte-électrode avec interrupteur digital double, grande fiche coax et câble de raccordement de 4 m
Manico portaelettrodi con due tasti, spina coassiale grande e cavo di connessione da 4 m

80-217-12-04 *max. 5500 V_p*

KLS Martin/Aesculap/Berchtold

Elektroden-Handgriff mit zwei Tasten, großem Koax-Stecker und 5 m Anschlusskabel
Electrode handle with two pushbuttons, large coax plug and connection cable of 5 m
Mango porta-electrodos con dos teclas, clavija coaxial grande y cable de conexión de 5 m
Manche porte-électrode avec interrupteur digital double, grande fiche coax et câble de raccordement de 5 m
Manico portaelettrodi con due tasti, spina coassiale grande e cavo di connessione da 5 m

Ø 4 mm

1/2



1/3



Ø 12,5 mm

Surgi-Pen

80-219-02-04 *max. 4000 V_p*

KLS Martin/Aesculap/Berchtold

Elektroden-Handgriff mit zwei Tasten, großem Koax-Stecker und 4 m Anschlusskabel
Electrode handle with two pushbuttons, large coax plug and connection cable of 4 m
Mango porta-electrodos con dos teclas, clavija coaxial grande y cable de conexión de 4 m
Manche porte-électrode avec interrupteur digital double, grande fiche coax et câble de raccordement de 4 m
Manico portaelettrodi con due tasti, spina coassiale grande e cavo di connessione da 4 m

80-219-12-04 *max. 4000 V_p*

KLS Martin/Aesculap/Berchtold

Elektroden-Handgriff mit zwei Tasten, großem Koax-Stecker und 5 m Anschlusskabel
Electrode handle with two pushbuttons, large coax plug and connection cable of 5 m
Mango porta-electrodos con dos teclas, clavija coaxial grande y cable de conexión de 5 m
Manche porte-électrode avec interrupteur digital double, grande fiche coax et câble de raccordement de 5 m
Manico portaelettrodi con due tasti, spina coassiale grande e cavo di connessione da 5 m

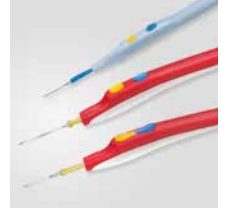

Passend für **maXium®/ME 411/ME 401/ME 400/ME 200**
 Suitable for **ME MB 3/ME MB 2/ME MB 1/ME M1/ME 102**
 Para
 Pour
 Per

Ø 4 mm

1/2



80-210-12-04 **max. 5500 V_p**

KLS Martin/Erbe intern. Version/Valleylab

Elektroden-Handgriff mit zwei Tasten, 3-Pin-Stecker und 5 m Anschlusskabel
 Electrode handle with two pushbuttons, 3-pin plug and connection cable of 5 m
 Mango porta-electrodos con dos teclas, clavija de 3 patillas y cable de conexión de 5 m
 Manche porte-électrode avec interrupteur digital double, fiche à 3 broches et câble de raccordement de 5 m
 Manico portaelettrodi con due tasti, spina a 3-spire e cavo di connessione da 5 m

1/3



Ø 4 mm

1/2



Surgi-Pen

80-219-42-04 **max. 4000 V_p**

KLS Martin/Erbe intern. Version/Valleylab

Elektroden-Handgriff mit zwei Tasten, 3-Pin-Stecker und 4 m Anschlusskabel
 Electrode handle with two pushbuttons, 3-pin plug and connection cable of 4 m
 Mango porta-electrodos con dos teclas, clavija de 3 patillas y cable de conexión de 4 m
 Manche porte-électrode avec interrupteur digital double, fiche à 3 broches et câble de raccordement de 4 m
 Manico portaelettrodi con due tasti, spina a 3-spire e cavo di connessione da 4 m

1/3



Ø 4 mm

1/2



80-225-00-04 **max. 4000 V_p**

Elektrodenhandgriff mit 2 Tasten, mit abnehmbarem Kabel
 Electrode handle with 2 pushbuttons, with detachable cable
 Mango portaelectrodos con 2 botones, con cable desmontable
 Manche d'électrode avec 2 touches, avec câble amovible
 Manico per elettrodi a due pulsanti, con cavo estraibile

1/3



80-225-01-04 **max. 4000 V_p**

KLS Martin/Aesculap/Berchtold

Anschlusskabel 4 m Länge
 Connecting cable 4 m
 Cable de conexión de 4 m de longitud
 Câble de raccordement long de 4 m
 Cavo di collegamento della lunghezza di 4 m

1/3



80-225-02-04 **max. 4000 V_p**

maXium® e, Erbe ACC/ICC/VIO

Anschlusskabel 4 m Länge
 Connecting cable 4 m
 Cable de conexión de 4 m de longitud
 Câble de raccordement long de 4 m
 Cavo di collegamento della lunghezza di 4 m

Monopolare Elektroden-Handgriffe
Monopolar electrode handles
Mangos porta-electrodos monopolares
Manches porte-électrodes monopolaires
Manici portaelettrodi monopolari

Passend für **maXium® e**
Suitable for
Para
Pour
Per



80-220-30-04 *max. 3000 V_p*
maXium® e/Erbe ICC/ACC/VIO

Elektroden-Handgriff ohne Taste, mit 5-mm-Stecker und 4 m Anschlusskabel
Electrode handle without pushbutton, with 5-mm plug and connection cable of 4 m
Mango porta-electrodos sin tecla, con clavija de 5 mm y cable de conexión de 4 m
Manche porte-électrode sans interrupteur, avec fiche de 5 mm et câble de raccordement de 4 m
Manico portaelettrodi senza tasto, con spina da 5 mm e cavo di connessione da 4 m



80-217-32-04 *max. 5500 V_p*
maXium® e/Erbe ICC/ACC/VIO

Elektroden-Handgriff mit zwei Tasten, mit 5-mm-Stecker und 4 m Anschlusskabel
Electrode handle with two pushbuttons, with 5-mm plug and connection cable of 4 m
Mango porta-electrodos con dos teclas, clavija de 5 mm y cable de conexión de 4 m
Manche porte-électrode avec interrupteur digital double, fiche de 5 mm et câble de raccordement de 4 m
Manico portaelettrodi con due tasti, spina da 5 mm e cavo di connessione da 4 m

Passend für **maXium® i, ME MB 3 i, ME MB 2 i**
Suitable for
Para
Pour
Per



80-220-40-04 *max. 3000 V_p*
maXium® i/ME MB 3 i/ME MB 2 i/Valleylab/Bovie

Elektroden-Handgriff ohne Tasten, mit 8-mm-Stecker und 4 m Anschlusskabel für Valleylab-Geräte
Electrode handle without pushbuttons, with 8-mm plug and connection cable of 4 m, for Valleylab units
Mango porta-electrodos sin teclas, con clavija de 8 mm y cable de conexión de 4 m para aparatos Valleylab
Manche porte-électrode sans interrupteur, avec fiche de 8 mm et câble de raccordement de 4 m pour appareils Valleylab
Manico portaelettrodi senza tasti, con spina da 8 mm e cavo di connessione da 4 m per apparecchi Valleylab

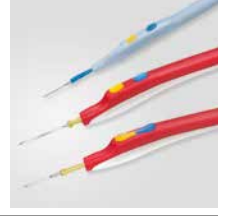

Passend für maXium®/ME 411/ME 401/ME 400/ME 200
 Suitable for ME MB 3/ME MB 2/ME MB 1/ME M1/ME 102
 Para
 Pour
 Per



80-221-02-04 max. 4100 V_p **STERILE IEO**
KLS Martin/Erbe intern. Version/Valleylab

Einmal-Handgriff mit Lanzette, steril verpackt, 4,2 m Anschlusskabel, VE=10 Stück
 Disposable handle with lancet, sterile packed, connection cable of 4.2 m, SU=10/pack
 Mango desechable con lanceta, envase estéril, cable de conexión de 4,2 m, UV=10 piezas
 Manche à usage unique avec lancette, emballage stérile, câble de raccordement de 4,2 m, UC=10 unités
 Manico monouso con lancetta, imballaggio sterile, cavo di connessione da 4,2 m, UV=10 pezzi

Passend für Aktivelektroden mit Ø 2,4 mm (siehe Seite 26)
 For active electrodes Ø 2.4 mm (see page 26)
 Para electrodos activos con Ø 2,4 mm (véase página 26)
 Pour électrodes actives Ø 2,4 mm (voir page 26)
 Per elettrodi attivi con Ø 2,4 mm (vedi a pag. 26)



80-210-16-04 max. 4000 V_p
KLS Martin/Erbe intern. Version/Valleylab

Elektroden-Handgriff mit zwei Tasten, 3-Pin-Stecker und 4 m Anschlusskabel
 Electrode handle with two pushbuttons, 3-pin plug and connection cable of 4 m
 Mango porta-electrodos con dos teclas, clavija de 3 patillas y cable de conexión de 4 m
 Manche porte-électrode avec interrupteur digital double, fiche à 3 broches et cable de raccordement de 4 m
 Manico porta elettrodi con due tasti, spina a 3-spire e cavo di connessione da 4 m



80-210-03-04 max. 5000 V_p
KLS Martin/Erbe intern. Version/Valleylab

Elektroden-Handgriff mit zwei Tasten, 3-Pin-Stecker und 4 m Anschlusskabel, 50 Aufbereitungszyklen
 Electrode handle with two pushbuttons, 3-pin plug and connection cable of 4 m, 50 reprocessing cycles
 Mango porta-electrodos con dos teclas, clavija de 3 patillas y cable de conexión de 4 m, 50 ciclos de procesamiento
 Manche porte-électrode avec interrupteur digital double, fiche à 3 broches et cable de raccordement de 4 m, 50 cycles de traitement
 Manico porta elettrodi con due tasti, spina a 3-spire e cavo di connessione da 4 m, 50 cicli di ricondizionamento

Monopolare Elektroden-Handgriffe
Monopolar electrode handles
Mangos porta-electrodos monopolares
Manches porte-électrodes monopolaires
Manici portaelettrodi monopolari

Passend für **MD 62/ME K1/ME K2/ME K3/ME 82/miniCutter**

Suitable for
Para
Pour
Per

Ø 1,6 mm



80-214-10-04 *max. 3500 V_p*

KLS Martin

Dental-Elektroden-Handgriff ohne Taste, mit großem Koax-Stecker und 3 m Anschlusskabel
Dental electrode handle without pushbutton, with large coax plug and connection cable of 3 m
Mango porta-electrodos dental sin tecla, con clavija coaxial grande y cable de conexión de 3 m
Manche porte-électrode dentaire sans interrupteur digital, avec grande fiche coax et câble de raccordement de 3 m
Manico portaelettrodi dentale senza tasto, con spina coassiale grande e cavo di connessione da 3 m

Ø 1,6 mm



80-214-11-04 *max. 2000 V_p*

KLS Martin

Dental-Elektroden-Handgriff mit einer Taste, mit großem Koax-Stecker und 3 m Anschlusskabel
Dental electrode handle with a pushbutton, with large coax plug and connection cable of 3 m
Mango porta-electrodos dental con una tecla, con clavija coaxial grande y cable de conexión de 3 m
Manche porte-électrode dentaire avec un interrupteur digital, avec grande fiche coax et câble de raccordement de 3 m
Manico portaelettrodi dentale con un tasto, con spina coassiale grande e cavo di connessione da 3 m

Ø 4 mm



80-217-01-04 *max. 5500 V_p*

KLS Martin

Elektroden-Handgriff mit einer Taste, großem Koax-Stecker und 4 m Anschlusskabel
Electrode handle with a pushbutton, large coax plug and connection cable of 4 m
Mango porta-electrodos con una tecla, clavija coaxial grande y cable de conexión de 4 m
Manche porte-électrode avec un interrupteur digital, grande fiche coax et câble de raccordement de 4 m
Manico portaelettrodi con un tasto, spina coassiale grande e cavo di connessione da 4 m



Passend für KLS-Martin-Geräte aus unserem früheren Programm
 Suitable for KLS Martin units of our former program
 Para aparatos KLS Martin de nuestra anterior gama de producción
 Pour appareils KLS Martin de notre ancienne gamme
 Per apparecchi KLS Martin della nostra gamma precedente

Ø 1,6 mm



80-214-00-04 *max. 3500 V_p*

Berchtold

Dental-Elektroden-Handgriff ohne Taste, mit kleinem Koax-Stecker und 3 m Anschlusskabel
 Dental electrode handle without pushbutton, with small coax plug and connection cable of 3 m
 Mango porta-electrodos dental sin tecla, con clavija coaxial pequeña y cable de conexión de 3 m
 Manche porte-électrode dentaire sans interrupteur digital, avec petite fiche coax et câble de raccordement de 3 m
 Manico portaelettrodi dentale senza tasto, con spina coassiale piccola e cavo di connessione da 3 m

Ø 1,6 mm



80-214-01-04 *max. 2000 V_p*

Berchtold

Dental-Elektroden-Handgriff mit einer Taste, mit kleinem Koax-Stecker und 3 m Anschlusskabel
 Dental electrode handle with one pushbutton, small coax plug and connection cable of 3 m
 Mango porta-electrodos dental con una tecla, con clavija coaxial pequeña y cable de conexión de 3 m
 Manche porte-électrode dentaire avec un interrupteur digital, avec petite fiche coax et câble de raccordement de 3 m
 Manico portaelettrodi dentale con un tasto, con spina coassiale piccola e cavo di connessione da 3 m

NON-CE



80-213-01-04 *max. 750 V_p*

Elektroden-Handgriff für Elektroden Ø 1,6 mm
 Electrode handle for electrodes Ø 1.6 mm
 Mango porta-electrodos para electrodos Ø 1,6 mm
 Manche porte-électrode pour électrodes Ø 1,6 mm
 Manico portaelettrodi per elettrodi Ø mm 1,6

NON-CE



80-280-30-04 *max. 4000 V_p*
 3 m/10 ft.

Anschlusskabel, einpolig,
 für Griff 80-213-01-04







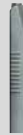
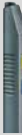
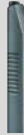

Connection cable, monopolar,
 for handle 80-213-01-04

Cable de conexión, monopolar,
 para mango 80-213-01-04

Câble de raccordement, monopolaire,
 pour manche 80-213-01-04

Cavo di connessione, monopolare,
 per manico 80-213-01-04

Handgriffe · Handles · Mangos · Manches · Manici

	80-220-00-04	80-217-01-04	80-217-02-04	80-217-12-04	80-219-02-04	80-219-12-04	80-219-42-04	80-210-12-04	80-225-00-04 & 80-225-01-04	80-225-00-04 & 80-225-02-04	80-181-02-04
Ø (mm)	4,0	4,0	4,0	4,0	4,0	4,0	4,0	4,0	4,0	4,0	
Gerätetyp Type of unit Tipo del aparato Type d'appareil Tipo d'apparecchio											
maXium® m	x*		x	x	x	x	x	x	x		x
maXium® i							x	x			x
maXium® e							x	x		x	x
maXium® smart C m	x*		x	x	x	x	x	x	x		x
maXium® smart C i							x	x			x
maXium® smart C e							x	x		x	x
ME 411	x*		x	x	x	x	x	x	x		x
ME 401	x*		x	x	x	x	x	x	x		x
ME 400	x*		x	x	x	x	x	x	x		x
ME 200	x*		x	x	x	x	x	x	x		x
ME MB 1	x*		x	x	x	x	x	x	x		x
ME M 1	x*		x	x	x	x	x	x	x		x
ME MB 2	x*		x	x	x	x	x	x	x		x
ME MB 3	x*		x	x	x	x	x	x	x		
ME 81	x*		x	x	x	x	x	x	x		
ME 82	x*	x					x	x	x		
miniCutter		x									
ME 102	x*		x	x	x	x	x	x	x		
ME 80	x*		x	x	x	x	x	x	x		
ME 50	x*		x	x	x	x	x	x	x		
ME K1		x		x							
ME K2		x		x							
ME 60		x		x							
MD 70		x		x							
MD 62		x		x							

Kombination Combination Combinación Combinaison Combinazione	
maXium®/Beamer	x
MB 181/ME 411	x
MB 181/ME CD1	x

x* = bei Verwendung eines Fußschalters
 for use with foot switch
 usando un interruptor de pie
 pour utilisation avec un interrupteur à pédale
 per l'uso di un interruttore a pedale



Handgriffe · Handles · Mangos · Manches · Manici

1

	80-221-02-04	80-210-03-04	80-210-16-04	80-214-10-04	80-214-11-04
Ø (mm)	2,4	2,4	2,4	1,6	1,6
Gerätetyp Type of unit Tipo del aparato Type d'appareil Tipo d'apparecchio					
maXium® m	x	x	x	x*	
maXium® i	x	x	x	x*	
maXium® e	x	x	x	x*	
maXium® smart C m	x	x	x	x*	
maXium® smart C i	x	x	x	x*	
maXium® smart C e	x	x	x	x*	
ME 411	x	x	x	x*	
ME 401	x	x	x	x*	
ME 400	x	x	x	x*	
ME 200	x	x	x	x*	
ME MB 1	x	x	x	x*	
ME M 1	x	x	x	x*	
ME MB 2	x	x	x	x*	
ME MB 3	x	x	x	x*	
ME 81	x	x	x	x*	
ME 82	x	x	x	x*	x
miniCutter				x*	x
ME 102	x	x	x	x*	
ME 80	x	x	x		
ME 50	x	x	x		
ME K1				x*	x
ME K2				x*	x
ME 60				x*	x
MD 70				x*	x
MD 62				x*	x

Kombination Combination Combinación Combinaison Combinazione
maXium®/Beamer
MB 181/ME 411
MB 181/ME CD1

x* = bei Verwendung eines Fußschalters
 for use with foot switch
 usando un interruptor de pie
 pour utilisation avec un interrupteur à pédale
 per l'uso di un interruttore a pedale

Monopolare Elektroden
Monopolar Electrodes
Electrodos monopolares
Electrodes monopolaires
Elettrodi monopolari

2



Monopolare Elektroden
 Monopolar electrodes
 Electrodo monopolares
 Electrodes monopolaires
 Elettrodi monopolari

KLS-Martin-SYN-Elektroden mit farbkodierter Kunststoffisolation
KLS Martin SYN electrodes with color-coded plastic insulation
SYN electrodo KLS Martin con aislamiento de plástico en color codificado
SYN électrodes KLS Martin avec isolation en matière plastique avec code couleur
SYN elettrodi KLS Martin con isolamento in materiale plastico con codice colore

Aktivelektroden mit Ø 4 mm
Active electrodes Ø 4 mm
Electrodos activos con Ø 4 mm
Electrodes actives Ø 4 mm
Elettrodi attivi Ø 4 mm

Reusable

Ø 4 mm  **max. 4000 V_p**



80-510-06-04

Lanzettelektrode, gerade, VE = 5 Stück
 Lancet electrode, straight, SU = 5/pack
 Electrodo de lanceta, recto, UV = 5 piezas
 Electrode lancette, droite, UC = 5 unités
 Elettrodo a lancetta, retto, UV = 5 pezzi



80-511-06-04

Lanzettelektrode, abgewinkelt, isoliert
 Lancet electrode, angled, insulated
 Electrodo de lanceta, acodado, aislado
 Electrode lancette, coudée, isolée
 Elettrodo a lancetta, angolato, isolato

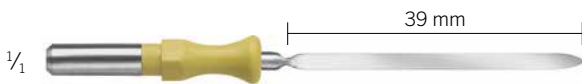

80-515-06-04

Messerelektrode, VE = 5 Stück
 Knife electrode, SU = 5/pack
 Electrodo de cuchillo, UV = 5 piezas
 Electrode couteau, UC = 5 unités
 Elettrodo a bisturi, UV = 5 pezzi

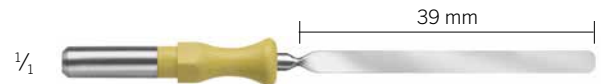

80-516-06-04

Mammaria-Spatel
 Mammary spatula (electrode)
 Electrodo de mammaria
 Electrode spatule
 Elettrodo a mammaria



80-520-06-04

Nadelelektrode, VE = 5 Stück
 Needle electrode, SU = 5/pack
 Electrodo de aguja, UV = 5 piezas
 Electrode aiguille, UC = 5 unités
 Elettrodo ad ago, UV = 5 pezzi



80-521-04-04

Nadelelektrode isoliert
 Needle electrode insulated
 Electrodo de aguja aislado
 Electrode aiguille isolée
 Elettrodo ad ago isolato



80-521-02-04

Nadelelektrode, VE = 5 Stück
 Needle electrode, SU = 5/pack
 Electrodo de aguja, UV = 5 piezas
 Electrode aiguille, UC = 5 unités
 Elettrodo ad ago, UV = 5 pezzi



80-522-04-04

Nadelelektrode isoliert
 Needle electrode insulated
 Electrodo de aguja aislado
 Electrode aiguille isolée
 Elettrodo ad ago isolato



Aktivelektroden mit Ø 4 mm
Active electrodes Ø 4 mm
Electrodo activos con Ø 4 mm
Electrodes actives Ø 4 mm
Elettrodi attivi Ø 4 mm

max. 4000 V_p



80-542-06-04

Drahtschlingenelektrode, Wolfram
 Wire loop electrode, tungsten
 Electrodo de asa de alambre, tungsteno
 Electrode anse en fil, en tungstène
 Elettrodo ad ansa di filo, tungsteno



80-550-06-04

Bandschlingenelektrode
 Ribbon loop electrode
 Electrodo de asa de cinta
 Electrode boucle
 Elettrodo ad ansa a nastro



80-560-06-04

Kugelelektrode, VE=5 Stück
 Ball electrode, SU=5/pack
 Electrodo de bola, UV=5 piezas
 Electrode boule, UC=5 unités
 Elettrodo a sfera, UV=5 pezzi



80-562-06-04

Kugelelektrode, VE=5 Stück
 Ball electrode, SU=5/pack
 Electrodo de bola, UV=5 piezas
 Electrode boule, UC=5 unités
 Elettrodo a sfera, UV=5 pezzi



80-580-06-04

Elektroden-Satz, bestehend aus: 1 x 80-510-06-04
 Electrode set, consisting of: 1 x 80-515-06-04
 Set electrodos, compuesto de: 1 x 80-520-06-04
 Set électrodes, composé de: 1 x 80-560-06-04
 Set elettrodi, composto da: 1 x 80-562-06-04

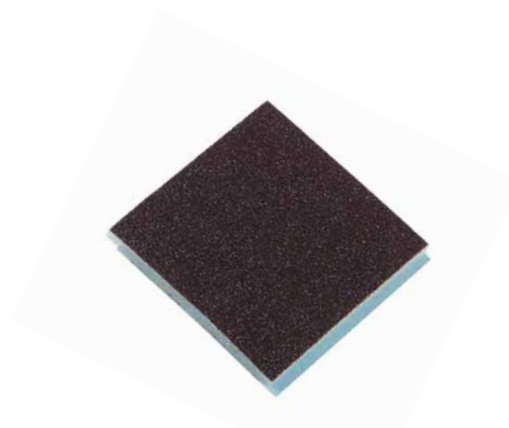

80-505-00-04 **STERILE IEO**

Reinigungspad für Elektroden, steril verpackt, VE=100 Stück
 Cleaning pad for electrodes, sterile packed, SU=100 /pack
 Almohadilla de limpieza para electrodos, embalado estéril, UV=100 piezas
 Tampon de nettoyage pour électrodes, emballage stérile, UC=100 unités
 Tampone di pulizia per elettrodi, imballaggio sterile, UV=100 pezzi

Monopolare Elektroden
 Monopolar electrodes
 Electrodo monopolar
 Electrodes monopolaires
 Elettrodi monopolari

KLS-Martin-SYN-Elektroden mit farbkodierter Kunststoffisolation
KLS Martin SYN electrodes with color-coded plastic insulation
SYN electrodo KLS Martin con aislamiento de plástico en color codificado
SYN électrodes KLS Martin avec isolation en matière plastique avec code couleur
SYN elettrodi KLS Martin con isolamento in materiale plastico con codice colore

Reusable

Aktivelektroden mit Ø 2,4 mm
Active electrodes Ø 2.4 mm
Electrodo activos con Ø 2,4 mm
Electrodes actives Ø 2,4 mm
Elettrodi attivi Ø 2,4 mm



80-520-09-04 **max. 2900 V_p**
 Nadelektrode für die Mikrodissektion, Wolframspitze,
 VE = 5 Stück, wiederverwendbar
 Needle electrode for dissection, tungsten tip,
 5 items/pack, reusable
 Electrodo de aguja para la disección, punta de tungsteno,
 UE = 5 unidades, reutilizable
 Electrode aiguille pour dissection, pointe en tungstène,
 UE = 5 pièces, réutilisable
 Elettrodo ad ago per dissezione, punta in tungsteno,
 UV = 5 unità, riutilizzabile



80-520-10-04 **max. 2900 V_p** **STERILE**
 Nadelektrode für die Mikrodissektion, Wolframspitze,
 VE = 5 Stück, steril verpackt, wiederverwendbar
 Needle electrode for dissection, tungsten tip,
 5 items/pack, sterile packed, reusable
 Electrodo de aguja para la disección, punta de tungsteno,
 UE = 5 unidades, embalado estéril, reutilizable
 Electrode aiguille pour dissection, pointe en tungstène,
 UE = 5 pièces, emballage stérile, réutilisable
 Elettrodo ad ago per dissezione, punta in tungsteno,
 UV = 5 unità, imballaggio sterile, riutilizzabile



80-510-08-04 **max. 3250 V_p**
 Lanzettelektrode, gerade
 Lancet electrode, straight
 Electrodo de lanceta, recto
 Electrode lancette, droite
 Elettrodo a lancetta, retto



80-515-08-04 **max. 3250 V_p**
 Messerelektrode
 Knife electrode
 Electrodo de cuchillo
 Electrode couteau
 Elettrodo a bisturi



80-520-08-04 **max. 3250 V_p**
 Nadelektrode
 Needle electrode
 Electrodo de aguja
 Electrode aiguille
 Elettrodo ad ago



80-542-08-04 **max. 3250 V_p**
 Drahtschlingenelektrode, Wolfram
 Wire loop electrode, tungsten
 Electrodo de asa de alambre, tungsteno
 Electrode anse en fil, en tungstène
 Elettrodo ad ansa di filo, tungsteno



80-562-08-04 **max. 3250 V_p**
 Kugelelektrode
 Ball electrode
 Electrodo de bola
 Electrode boule
 Elettrodo a sfera



KLS-Martin-Edelstahlelektroden
KLS Martin stainless steel electrodes
Electrodos KLS Martin de acero inoxidable
Electrodes KLS Martin en acier inoxydable
Elettrodi KLS Martin in acciaio inox

Aktivelektroden mit Ø 4 mm
Active electrodes Ø 4 mm
Electrodos activos con Ø 4 mm
Electrodes actives Ø 4 mm
Elettrodi attivi Ø 4 mm



80-510-04-04
 Lanzettelektrode, gerade
 Lancet electrode, straight
 Electrodo de lanceta, recto
 Electrode lancette, droite
 Elettrodo a lancetta, retto



80-511-04-04
 Lanzettelektrode, abgewinkelt
 Lancet electrode, angled
 Electrodo de lanceta, acodado
 Electrode lancette, coudée
 Elettrodo a lancetta, angolato



80-540-04-04 = Ø 5 mm
 80-542-04-04 = Ø 10 mm
 80-545-04-04 = Ø 20 mm
 Drahtschlingenelektrode
 Wire loop electrode
 Electrodo de asa de alambre
 Electrode anse en fil
 Elettrodo ad ansa di filo



80-515-04-04
 Messerelektrode
 Knife electrode
 Electrodo de cuchillo
 Electrode couteau
 Elettrodo a bisturi



80-550-04-04 = Ø 10 mm
 80-552-04-04 = Ø 15 mm
 Bandschlingenelektrode
 Ribbon loop electrode
 Electrodo de asa de cinta
 Electrode boucle
 Elettrodo ad ansa a nastro

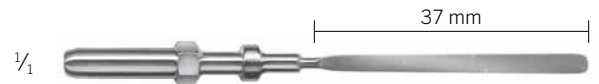

80-516-04-04
 Mammaria-Spatel
 Mammary spatula (electrode)
 Electrodo de mammaria
 Electrode spatule
 Elettrodo a mammaria



80-519-04-04
 Nadelelektrode
 Needle electrode
 Electrodo de aguja
 Electrode aiguille
 Elettrodo ad ago



80-520-04-04
 Nadelelektrode
 Needle electrode
 Electrodo de aguja
 Electrode aiguille
 Elettrodo ad ago



80-570-04-04 = 8 x 10 mm
 80-572-04-04 = 10 x 10 mm
 80-574-04-04 = 12 x 10 mm
 Plattenelektrode
 Plate electrode
 Electrodo de placa
 Electrode plaque
 Elettrodo a piastra



80-560-04-04 = Ø 2 mm
 80-562-04-04 = Ø 4 mm
 80-563-04-04 = Ø 5 mm
 Kugelelektrode
 Ball electrode
 Electrodo de bola
 Electrode boule
 Elettrodo a sfera

Monopolare Elektroden
 Monopolar electrodes
 Electrodo monopolar
 Electrodes monopolaires
 Elettrodi monopolari

Aktivelektroden mit Ø 4 mm
Active electrodes Ø 4 mm
Electrodos activos con Ø 4 mm
Electrodes actives Ø 4 mm
Elettrodi attivi Ø 4 mm

Wolfram
Tungsten
Tungsteno
En tungstène
Tungsteno

Reusable



max. 650 V_p

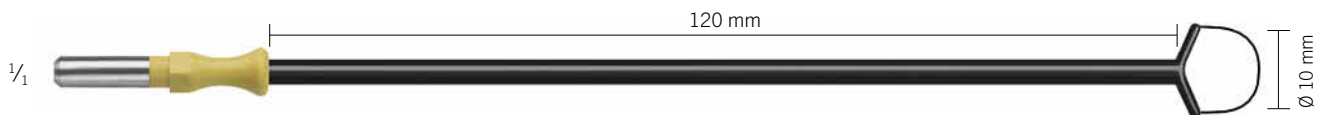

80-680-12-04
 Konisationselektrode
 Conization electrode
 Electrodo para conización
 Electrode pour l'électroconisation
 Elettrodo per conizzazione



80-681-12-04
 Konisationselektrode
 Conization electrode
 Electrodo para conización
 Electrode pour l'électroconisation
 Elettrodo per conizzazione

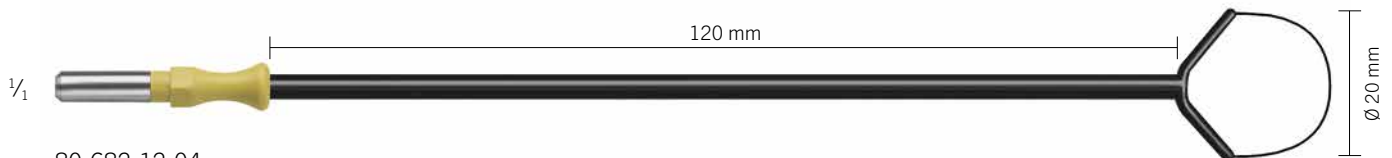

80-682-12-04
 Konisationselektrode
 Conization electrode
 Electrodo para conización
 Electrode pour l'électroconisation
 Elettrodo per conizzazione

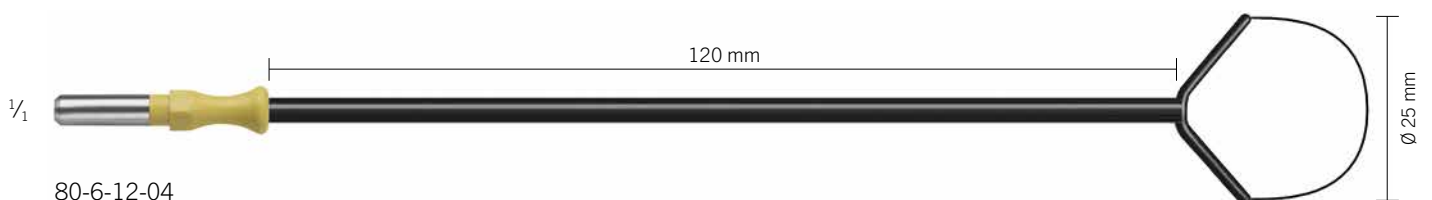

80-6-12-04
 Konisationselektrode
 Conization electrode
 Electrodo para conización
 Electrode pour l'électroconisation
 Elettrodo per conizzazione



Aktivelektroden mit Ø 4 mm
Active electrodes Ø 4 mm
Electrodo activos con Ø 4 mm
Electrodes actives Ø 4 mm
Elettrodi attivi Ø 4 mm

Wolfram
Tungsten
Tungsteno
En tungstène
Tungsteno

Weitere Informationen entnehmen Sie bitte der separaten Broschüre.

For further information please refer to our separate product brochure.

Encontrará informaciones adicionales en el folleto individual.

Vous trouverez des informations supplémentaires dans la brochure.

Per ulteriori informazioni vedasi il prospetto separato.



2

Ø 4 mm

max. 650 V_p

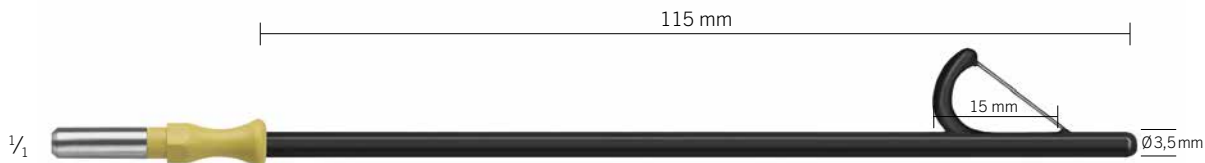

80-684-12-04

Konisationselektrode nach Scarfi
 Conization electrode
 Electrodo para conización
 Electrode pour l'électroconisation
 Elettrodo per conizzazione



80-685-12-04

Konisationselektrode nach Scarfi
 Conization electrode
 Electrodo para conización
 Electrode pour l'électroconisation
 Elettrodo per conizzazione

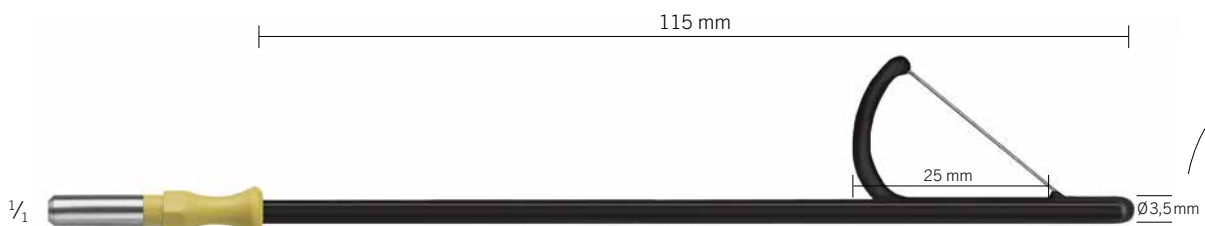

80-686-12-04

Konisationselektrode nach Scarfi
 Conization electrode
 Electrodo para conización
 Electrode pour l'électroconisation
 Elettrodo per conizzazione

Monopolare Elektroden
Monopolar electrodes
Electrodos monopolares
Electrodes monopolaires
Elettrodi monopolari

Reusable

Aktivelektroden mit Ø 4 mm
Active electrodes Ø 4 mm
Electrodos activos con Ø 4 mm
Electrodes actives Ø 4 mm
Elettrodi attivi Ø 4 mm



80-675-13-04 **max. 3500 V_p**

Nadelelektrode, isoliert
Needle electrode, insulated
Electrodo de aguja, aislado
Electrode aiguille, isolée
Elettrodo ad ago, isolato

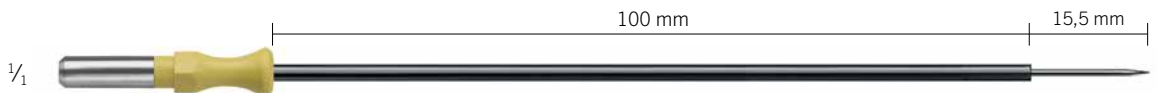

80-677-12-04 **max. 3500 V_p**

Nadelelektrode, isoliert
Needle electrode, insulated
Electrodo de aguja, aislado
Electrode aiguille, isolée
Elettrodo ad ago, isolato

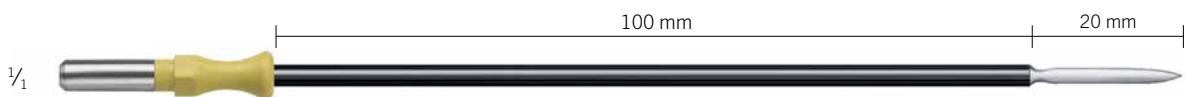

80-510-12-04 **max. 4000 V_p**

Lanzettelektrode, isoliert
Lancet electrode, insulated
Electrodo de lanceta, aislado
Electrode lancette, isolée
Elettrodo a lancetta, isolato



80-515-12-04 **max. 4000 V_p**

Messerelektrode, isoliert
Knife electrode, insulated
Electrodo de cuchillo, aislado
Electrode couteau, isolée
Elettrodo a bisturi, isolato



Aktivelektroden mit Ø 4 mm
Active electrodes Ø 4 mm
Electrodo activos con Ø 4 mm
Electrodes actives Ø 4 mm
Elettrodi attivi Ø 4 mm

Ø 4 mm  **max. 4000 V_p**



80-515-14-04
 Messerelektrode, kurz, isoliert
 Knife electrode, short, insulated
 Electrodo de cuchillo, corto, aislado
 Electrode couteau, courte, isolée
 Elettrodo a bisturi, corto, isolato



80-515-16-04
 Messerelektrode, kurz, abgewinkelt, isoliert
 Knife electrode, short, angled, insulated
 Electrodo de cuchillo, corto, acodado, aislado
 Electrode couteau, courte, coudée, isolée
 Elettrodo a bisturi, corto, angolato, isolato



80-540-12-04
 Drahtschlingenelektrode, isoliert, Wolfram
 Wire loop electrode, insulated, tungsten
 Electrodo de asa de alambre, aislado, tungsteno
 Electrode anse en fil, isolée, en tungstène
 Elettrodo ad ansa di filo, isolato, tungsteno

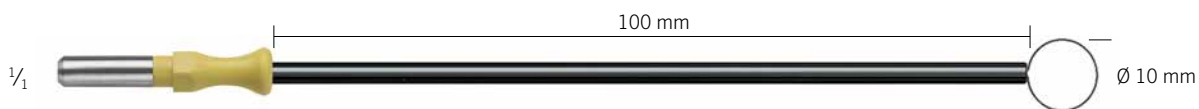

80-542-12-04
 Drahtschlingenelektrode, isoliert, Wolfram
 Wire loop electrode, insulated, tungsten
 Electrodo de asa de alambre, aislado, tungsteno
 Electrode anse en fil, isolée, en tungstène
 Elettrodo ad ansa di filo, isolato, tungsteno

Monopolare Elektroden
 Monopolar electrodes
 Electrodo monopolar
 Electrodes monopolaires
 Elettrodi monopolari

Reusable

Aktivelektroden mit Ø 4 mm
Active electrodes Ø 4 mm
Electrodos activos con Ø 4 mm
Electrodes actives Ø 4 mm
Elettrodi attivi Ø 4 mm



80-674-12-04 **max. 4000 V_p**
 Kugelelektrode, isoliert
 Ball electrode, insulated
 Electrodo de bola, aislado
 Electrode boule, isolée
 Elettrodo a sfera, isolato

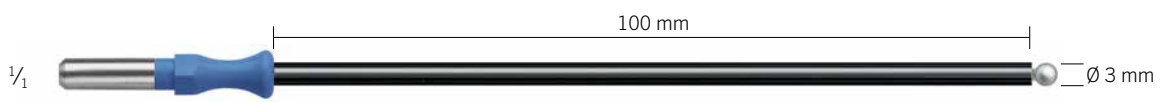

80-674-13-04 **max. 4000 V_p**
 Kugelelektrode, isoliert
 Ball electrode, insulated
 Electrodo de bola, aislado
 Electrode boule, isolée
 Elettrodo a sfera, isolato



80-676-13-04 **max. 3500 V_p**
 Kugelelektrode, isoliert
 Ball electrode, insulated
 Electrodo de bola, aislado
 Electrode boule, isolée
 Elettrodo a sfera, isolato



80-534-06-04 **max. 2000 V_p**
 Elektroden-Verlängerung, isoliert, biegsam, Ø 4 mm/Ø 4 mm
 Electrode extension, insulated, flexible, Ø 4 mm/Ø 4 mm
 Extensión de electrodo, aislada, flexible, Ø 4 mm/Ø 4 mm
 Prolongation d'électrode, isolée, flexible, Ø 4 mm/Ø 4 mm
 Prolunga per elettrodo, isolata, flessibile, Ø 4 mm/Ø 4 mm



80-534-12-04 **max. 2000 V_p**
 Elektroden-Verlängerung, isoliert, biegsam, Ø 4 mm/Ø 4 mm
 Electrode extension, insulated, flexible, Ø 4 mm/Ø 4 mm
 Extensión de electrodo, aislada, flexible, Ø 4 mm/Ø 4 mm
 Prolongation d'électrode, isolée, flexible, Ø 4 mm/Ø 4 mm
 Prolunga per elettrodo, isolata, flessibile, Ø 4 mm/Ø 4 mm



Aktivelektroden mit Ø 2,4 mm
Active electrodes Ø 2.4 mm
Electrodoes activos con Ø 2,4 mm
Electrodes actives Ø 2,4 mm
Elettrodi attivi Ø 2,4 mm

Ø 2,4 mm 



80-678-10-04 **max. 3250 V_p**

Messerelektrode, isoliert
 Knife electrode, insulated
 Electrodo de cuchillo, aislado
 Electrode couteau, isolée
 Elettrodo a bisturi, isolato



80-678-11-04 **max. 3250 V_p**

Kugelelektrode, isoliert
 Ball electrode, insulated
 Electrodo de bola, aislado
 Electrode boule, isolée
 Elettrodo a sfera, isolato



80-678-05-04 **max. 2000 V_p**

Elektroden-Verlängerung, Ø 2,4 mm / Ø 2,4 mm, Länge = 14 cm
 Electrode extension, Ø 2.4 mm / Ø 2.4 mm, length = 14 cm
 Extensión de electrodo, Ø 2,4 mm / Ø 2,4 mm, longitud = 14 cm
 Rallonge d'électrode, Ø 2,4 mm / Ø 2,4 mm, longueur = 14 cm
 Prolunga per elettrodo, Ø 2,4 mm / Ø 2,4 mm, lunghezza = 14 cm

Monopolare Elektroden für die HNO
Monopolar electrodes for ENT
Electrodos monopolares para la otorrinolaringología
Electrodes monopolaires pour l'O.R.L.
Elettrodi monopolari per l'otorinolaringoiatria

Aktivelektroden mit Ø 4 mm
Active electrodes Ø 4 mm
Electrodos activos con Ø 4 mm
Electrodes actives Ø 4 mm
Elettrodi attivi Ø 4 mm

Reusable

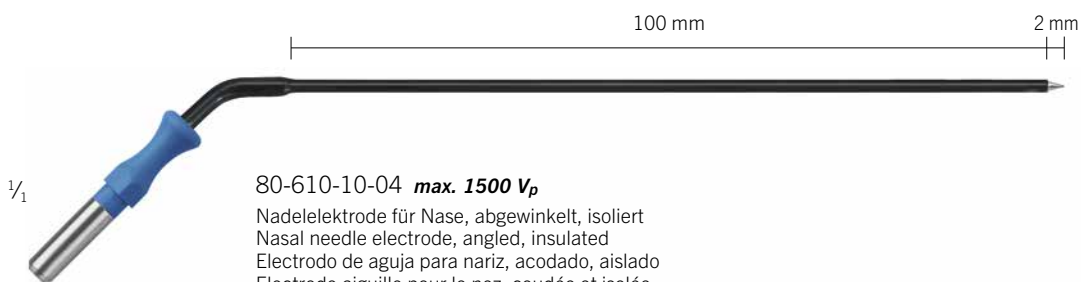

80-610-10-04 max. 1500 V_p
Nadelelektrode für Nase, abgewinkelt, isoliert
Nasal needle electrode, angled, insulated
Electrodo de aguja para nariz, acodado, aislado
Electrode aiguille pour le nez, coudée et isolée
Elettrodo ad ago per naso, angolato ed isolato

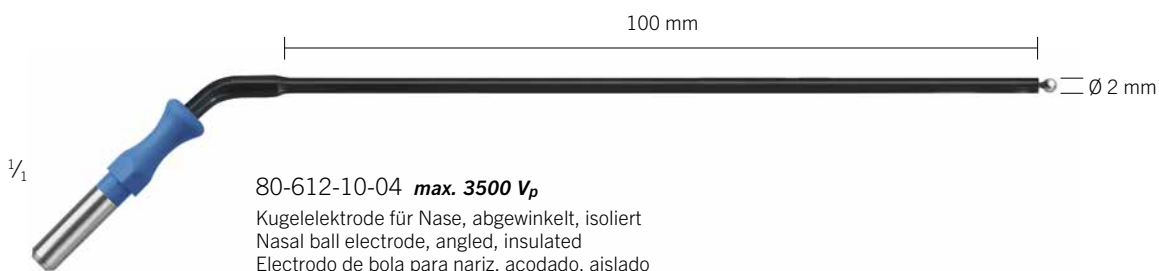

80-612-10-04 max. 3500 V_p
Kugelelektrode für Nase, abgewinkelt, isoliert
Nasal ball electrode, angled, insulated
Electrodo de bola para nariz, acodado, aislado
Electrode boule pour le nez, coudée et isolée
Elettrodo a sfera per naso, angolato ed isolato



Aktivelektroden mit Ø 4 mm
Active electrodes Ø 4 mm
Electrodos activos con Ø 4 mm
Electrodes actives Ø 4 mm
Elettrodi attivi Ø 4 mm

Ø 4 mm  **max. 5500 V_p**



80-690-12-04
 Nadelelektrode, isoliert, 90° abgewinkelt
 Needle electrode, insulated, 90° angled
 Electrodo de aguja, aislado, acodado 90°
 Electrode aiguille, isolée, coudée 90°
 Elettrodo ad ago, isolato, angolo 90°



80-691-12-04
 Nadelelektrode, isoliert, 90° abgewinkelt
 Needle electrode, insulated, 90° angled
 Electrodo de aguja, aislado, acodado 90°
 Electrode aiguille, isolée, coudée 90°
 Elettrodo ad ago, isolato, angolo 90°



80-692-12-04
 Nadelelektrode, isoliert, 45° abgewinkelt
 Needle electrode, insulated, 45° angled
 Electrodo de aguja, aislado, acodado 45°
 Electrode aiguille, isolée, coudée 45°
 Elettrodo ad ago, isolato, angolo 45°



80-693-12-04
 Messerelektrode, isoliert, 45° abgewinkelt
 Knife electrode, insulated, 45° angled
 Electrodo de cuchillo, aislado, acodado 45°
 Electrode couteau, isolée, coudée 45°
 Elettrodo a bisturi, isolato, angolo 45°



80-694-12-04
 Tastelektrode, isoliert, 90° abgewinkelt
 Probe electrode, insulated, 90° angled
 Electrodo de sondeo, aislado, acodado 90°
 Electrode sonde, isolée, coudée 90°
 Elettrodo sensore, isolato, angolo 90°



80-695-12-04
 Kugelelektrode
 Ball electrode
 Electrodo de bola
 Electrode boule
 Elettrodo a sfera

Reusable

Elektroden mit Ø 1,6 mm
Electrodes Ø 1.6 mm
Electrodoes con Ø 1,6 mm
Electrodes Ø 1,6 mm
Elettrodi Ø 1,6 mm

Ø 1,6 mm  *max. 500 V_p*



80-461-01-04

Fig. 1

Nadelelektrode, gerade
 Needle electrode, straight
 Electrodo de aguja, recto
 Electrode aiguille, droite
 Elettrodo ad ago, retto



80-462-01-04

Fig. 1

Nadelelektrode, kurz, gerade
 Needle electrode, short, straight
 Electrodo de aguja, corto, recto
 Electrode aiguille, courte, droite
 Elettrodo ad ago, corto, retto



80-466-01-04

Fig. 1

Nadelelektrode, gerade
 Needle electrode, straight
 Electrodo de aguja, recto
 Electrode aiguille, droite
 Elettrodo ad ago, retto



80-463-01-04

Fig. 1

Nadelelektrode, kurz, gerade
 Needle electrode, short, straight
 Electrodo de aguja, corto, recto
 Electrode aiguille, courte, droite
 Elettrodo ad ago, corto, retto



80-461-02-04

Fig. 2

Nadelelektrode, 45° abgewinkelt
 Needle electrode, 45° angled
 Electrodo de aguja, acodado 45°
 Electrode aiguille, coudée en 45°
 Elettrodo ad ago, angolo 45°



80-462-02-04

Fig. 2

Nadelelektrode, 45° abgewinkelt
 Needle electrode, 45° angled
 Electrodo de aguja, acodado 45°
 Electrode aiguille, coudée en 45°
 Elettrodo ad ago, angolo 45°



80-464-02-04

Fig. 2

Nadelelektrode, 45° abgewinkelt, **mit ausziehbarem und kürzbarem Draht**
 Needle electrode, 45° angled, **with extendable wire that can be cut as well**
 Electrodo de aguja, acodado 45°, **con alambre extensible que también puede acortarse**
 Electrode aiguille, coudée 45°, **avec fil extensible et raccourcissable**
 Elettrodo ad ago, angolo 45°, **con filo metallico estraibile ed accorciabile**



80-461-03-04

Fig. 3

Nadelelektrode, 120° abgewinkelt
 Needle electrode, 120° angled
 Electrodo de aguja, acodado 120°
 Electrode aiguille, coudée en 120°
 Elettrodo ad ago, angolo 120°



Elektroden mit Ø 1,6 mm	Drahtstärke der Drahtschlingenelektroden = Ø 0,2 mm
Electrodes Ø 1.6 mm	Wire size of wire loop electrodes = Ø 0.2 mm
Electrodo con Ø 1,6 mm	Grosor del alambre del electrodo de asa = Ø 0,2 mm
Electrodes Ø 1,6 mm	Epaisseur du fil des électrodes anse = Ø 0,2 mm
Elettrodi Ø 1,6 mm	Spessore filo degli elettrodi ad ansa = Ø 0,2 mm

Ø 1,6 mm max. 500 V_p



80-464-38-04

Fig. 2

Nadelelektrode, 45° abgewinkelt,
verlängerte Isolation, mit ausziehbarem und kürzbarem Draht
 Needle electrode, 45° angled
extended insulation, with extendable wire that can be cut as well
 Electrodo de aguja, acodado 45°
aislamiento prolongado, con alambre extensible que también puede acortarse
 Electrode aiguille, coudée 45°
isolation rallongée, avec fil extensible et raccourcissable
 Elettrodo ad ago, angolo 45°
isolamento prolungato, con filo metallico estraibile ed accorciabile



80-461-04-04

Nadelelektroden nach Dr. Haus, links und rechts, 1 Paar
 Needle electrodes acc. to Dr. Haus, left and right, 1 pair
 Electrodo de aguja según Dr. Haus, izquierdo y derecho, un par
 Electrodes aiguille selon Dr. Haus, gauche et droite, 1 paire
 Elettrodi ad ago secondo Dr. Haus, sinistro e destro, 1 paio



80-461-06-04

Fig. 6

Drahtschlingenelektrode, Schaft 45° abgewinkelt
 Wire loop electrode, shaft 45° angled
 Electrodo de asa de alambre, vástago acodado 45°
 Electrode anse, tige coudée en 45°
 Elettrodo ad ansa, asta curva a 45°



80-461-07-04

Scheibenelektrode, Schaft 45° abgewinkelt
 Disk electrode, shaft 45° angled
 Electrodo de disco, vástago acodado 45°
 Electrode discoïdale, tige coudée en 45°
 Elettrodo a disco, asta curva a 45°



80-461-11-04

Fig. 11

Drahtschlingenelektrode
 Wire loop electrode
 Electrodo de asa de alambre
 Electrode anse
 Elettrodo ad ansa



80-462-11-04

Fig. 11

Drahtschlingenelektrode
 Wire loop electrode
 Electrodo de asa de alambre
 Electrode anse
 Elettrodo ad ansa



80-461-12-04

Fig. 12

Drahtschlingenelektrode
 Wire loop electrode
 Electrodo de asa de alambre
 Electrode anse
 Elettrodo ad ansa



80-462-12-04

Fig. 12

Drahtschlingenelektrode
 Wire loop electrode
 Electrodo de asa de alambre
 Electrode anse
 Elettrodo ad ansa



80-461-13-04

Fig. 13

Drahtschlingenelektrode
 Wire loop electrode
 Electrodo de asa de alambre
 Electrode anse
 Elettrodo ad ansa



80-462-13-04

Fig. 13

Drahtschlingenelektrode
 Wire loop electrode
 Electrodo de asa de alambre
 Electrode anse
 Elettrodo ad ansa

Elektroden mit Ø 1,6 mm	Drahtstärke der Drahtschlingenelektroden = Ø 0,2 mm
Electrodes Ø 1.6 mm	Wire size of wire loop electrodes = Ø 0.2 mm
Electrodoes con Ø 1,6 mm	Grosor del alambre del electrodo de asa = Ø 0,2 mm
Electrodes Ø 1,6 mm	Epaisseur du fil des électrodes anse = Ø 0,2 mm
Elettrodi Ø 1,6 mm	Spessore filo degli elettrodi ad ansa = Ø 0,2 mm

Reusable

Ø 1,6 mm  max. 500 V_p



80-461-14-04

Fig. 14

8,0 x 5,0 mm

Drahtschlingenelektrode, rhombusförmig
 Wire loop electrode, rhombic
 Electrodo de asa de alambre romboidal
 Electrode anse, romboïdale
 Elettrodo ad ansa a forma di rombo



80-461-15-04

Fig. 15

7,0 x 1,5 mm

Drahtschlingenelektrode, länglich, Schaft 45° abgewinkelt
 Wire loop electrode, elongated, shaft 45° angled
 Electrodo de asa de alambre oblonga, vástago acodado 45°
 Electrode anse, forme allongée, tige coudée en 45°
 Elettrodo ad ansa retta, asta curva a 45°



80-461-16-04

Fig. 16

7 mm

Hakenelektrode, 45° abgewinkelt
 Hook electrode, 45° angled
 Electrodo de gancho, vástago acodado 45°
 Electrode crochet, tige coudée 45°
 Elettrodo ad uncino, 7 mm, asta curva a 45°



80-461-17-04

Fig. 17

6,0 x 1,3 mm

Drahtschlingenelektrode, länglich, gerade
 Wire loop electrode, elongated, straight
 Electrodo de asa de alambre oblonga, recto
 Electrode anse, forme allongée, droite
 Elettrodo ad ansa retta



80-461-18-04

Fig. 18

7,0 x 1,7 mm

Drahtschlingenelektrode, länglich, 30° abgewinkelt
 Wire loop electrode, elongated, 30° angled
 Electrodo de asa de alambre oblonga, acodado 30°
 Electrode anse, forme allongée, coudée en 30°
 Elettrodo ad ansa curva, angolo 30°



80-461-19-04

Fig. 19

5,5 x 1,4 mm

Drahtschlingenelektrode, länglich, 90° abgewinkelt
 Wire loop electrode, elongated, 90° angled
 Electrodo de asa de alambre oblonga, acodado 90°
 Electrode anse, forme allongée, coudée en 90°
 Elettrodo ad ansa curva, angolo 90°



80-461-20-04

Fig. 20

7,0 x 1,4 mm

Drahtschlingenelektrode, länglich, 45° abgewinkelt
 Wire loop electrode, elongated, 45° angled
 Electrodo de asa de alambre oblonga, acodado 45°
 Electrode anse, forme allongée, coudée en 45°
 Elettrodo ad ansa curva, angolo 45°



80-461-21-04

Fig. 21

7,0 x 1,3 mm

Drahtschlingenelektrode, länglich, gerade
 Wire loop electrode, elongated, straight
 Electrodo de asa de alambre oblonga, recto
 Electrode anse, forme allongée, droite
 Elettrodo ad ansa retta



Elektroden mit Ø 1,6 mm
Electrodes Ø 1.6 mm
Electrodoos con Ø 1,6 mm
Electrodes Ø 1,6 mm
Elettrodi Ø 1,6 mm

Ø 1,6 mm  **max. 500 V_p**



80-461-23-04
 Implantationselektrode, 45° abgewinkelt,
 Implantatology electrode, 45° angled
 Electrodo per implantologia, acodado 45°
 Electrode pour implantologie, coudée en 45°
 Elettrodo per implantologia, angolo 45°



80-461-22-04
 Fig. 22
 13,0 x 1,0 mm
 Drahtschlingenelektrode, länglich, 45° abgewinkelt
 Wire loop electrode, elongated, 45° angled
 Electrodo de asa de alambre oblonga, acodado 45°
 Electrode anse, forme allongée, coudée en 45°
 Elettrodo ad ansa curva, angolo 45°



80-461-24-04
 Fig. 24
 8 x 5 mm
 Drahtschlingenelektrode, rhombusförmig, Schaft 45° abgewinkelt
 Wire loop electrode, rhombic, shaft 45° angled
 Electrodo de asa de alambre romboidal, vástago acodado 45°
 Electrode anse, rhomboïdale, tige coudée en 45°
 Elettrodo ad ansa, forma di rombo, 8 x 5 mm, asta curva a 45°



80-461-31-04
 Fig. 31
 Ø 0,6 mm
 Koagulations-Nadelelektrode, 45° abgewinkelt
 Needle electrode for coagulation, 45° angled
 Electrodo de aguja para la coagulación, acodado 45°
 Electrode aiguille pour la coagulation, coudée en 45°
 Elettrodo ad ago per coagulazione, asta curva a 45°



80-461-32-04
 Fig. 32
 Ø 1,7 mm
 Koagulations-Nadelelektrode, 30° abgewinkelt
 Needle electrode for coagulation, 30° angled
 Electrodo de aguja para la coagulación, acodado 30°
 Electrode aiguille pour la coagulation, coudée en 30°
 Elettrodo ad ago per coagulazione, asta curva a 30°

Reusable

Elektroden mit Ø 1,6 mm
Electrodes Ø 1.6 mm
Electrodo con Ø 1,6 mm
Electrodes Ø 1,6 mm
Elettrodi Ø 1,6 mm

Ø 1,6 mm  **max. 500 V_p**



80-461-33-04

Fig. 33

Kugelelektrode, 45° abgewinkelt
 Ball electrode, 45° angled
 Electrodo de bola, 45° acodado
 Electrode boule, coudée en 45°
 Elettrodo a sfera, asta curva a 45°



80-461-34-04

Fig. 34

Kugelelektrode, 45° abgewinkelt
 Ball electrode, 45° angled
 Electrodo de bola, 45° acodado
 Electrode boule, coudée en 45°
 Elettrodo a sfera, asta curva a 45°



80-461-35-04

Fig. 35

Koagulations- und Fulgurationselektrode, gerade
 Coagulation and fulguration electrode, straight
 Electrodo para la coagulación y la fulguración, recto
 Electrode de coagulation et fulguration, droite
 Elettrodo per folgorazione e coagulazione, retto



80-461-36-04

Fig. 36

Koagulations- und Fulgurationselektrode, 90° abgewinkelt
 Coagulation and fulguration electrode, 90° angled
 Electrodo para la coagulación y la fulguración, acodado 90°
 Electrode de coagulation et fulguration, coudée en 90°
 Elettrodo per folgorazione e coagulazione, angolo 90°



80-461-37-04

Nadelelektrode, 45° abgewinkelt
 Needle electrode, 45° angled
 Electrodo de aguja, acodado 45°
 Electrode aiguille, coudée en 45°
 Elettrodo ad ago, angolo 45°

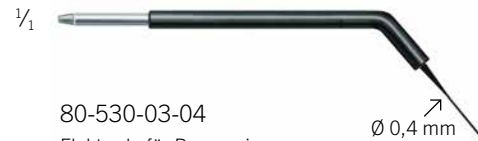

80-530-03-04

Elektrode für Besenreiser
 Electrode for varices/spider-bursts
 Electrodo para verrugas
 Electrode pour varices
 Elettrodo per varici



80-530-04-04

Couperosa-Elektrode
 Electrode for rosacea/teleangiectasias
 Electrodo para couperosa
 Electrode pour couperose
 Elettrodo per cuperosa



Elektroden mit Ø 0,8 mm
Electrodes Ø 0.8 mm
Electrodoos con Ø 0,8 mm
Electrodes Ø 0,8 mm
Elettrodi Ø 0,8 mm

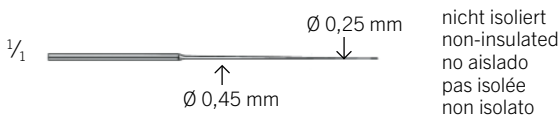

80-525-04-04

Nadelelektrode, 1 Dutzend
 Needle electrode, 1 dozen
 Electrodo de aguja, 1 docena
 Electrode aiguille, 1 douzaine
 Elettrodo ad ago, 1 dozzina

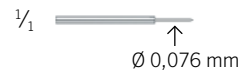

80-530-05-04 **STERILE IR**

Epilationselektrode, K3S short, Schaft 0,8 mm, 50/Pck.
 Epilation electrode, K3S short, shaft 0.8 mm, 50/pack
 Electrodo de depilación, K3S short, vástago de 0,8 mm, 50/unid.
 Electrode dépilation, K3S short, tige de 0,8 mm, 50/unité
 Elettrodo per depilazione, K3S short, asta di 0,8 mm, 50/unità

Aktivelektroden mit Ø 4 mm
Active electrodes Ø 4 mm
Electrodoos activos con Ø 4 mm
Electrodes actives Ø 4 mm
Elettrodi attivi Ø 4 mm



80-563-05-04

Faltenglättungselektrode, passend in Handgriff 80-217-01-04
 Wrinkle smoothing electrode, for electrode handle 80-217-01-04
 Electrodo antiarrugas, para mango porta-electrodoos 80-217-01-04
 Electrode pour lisser des rides, pour manche 80-217-01-04
 Elettrodo per rughe, utilizzabile con il manipolo 80-217-01-04

Elektroden-Adapter für monopolare Handgriffe
 Electrode adapter for monopolar handles
 Adaptador de electrodos para mangos monopolares
 Adaptateur pour manches monopolaires
 Adattatore elettrodo per manipoli monopolari

Elektrodenfixierung über Schraubkappe

Electrode fixation with screw cap

Fijación de electrodos con tapa roscada

Fixation de l'électrode à l'aide du bouchon à vis

Fissaggio elettrodo tramite tappo a vite

Reusable



80-460-04-04 max. 3700 V_p

Adapter von Ø 4 mm auf Ø 1,6 mm, z.B. Dental-Elektroden
 Adapter from Ø 4 mm to Ø 1.6 mm, e.g. for dental electrodes
 Adaptador de Ø 4 mm a Ø 1,6 mm, p.e. para electrodos dentales
 Adaptateur de Ø 4 mm à Ø 1,6 mm, p.e. pour électrodes dentaires
 Adattatore da Ø 4 mm a Ø 1,6 mm, p.e. per elettrodi dentali



80-531-00-04 max. 3700 V_p

Adapter von Ø 4 mm auf Ø 3/32" = 2,4 mm
 Adapter from Ø 4 mm to Ø 3/32" = 2.4 mm
 Adaptador de Ø 4 mm a Ø 3/32" = 2,4 mm
 Adaptateur de Ø 4 mm à Ø 3/32" = 2,4 mm
 Adattatore da Ø 4 mm a Ø 3/32" = 2,4 mm



80-532-00-04 max. 3700 V_p

Adapter von Ø 4 mm auf Ø 0,8 mm
 Adapter from Ø 4 mm to Ø 0.8 mm
 Adaptador de Ø 4 mm a Ø 0,8 mm
 Adaptateur de Ø 4 mm à Ø 0,8 mm
 Adattatore da Ø 4 mm a Ø 0,8 mm

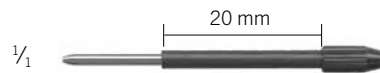

80-533-00-04 max. 50 V_p

Adapter von Ø 1,6 mm auf Ø 0,8 mm
 Adapter from Ø 1.6 mm to Ø 0.8 mm
 Adaptador de Ø 1,6 mm a Ø 0,8 mm
 Adaptateur de Ø 1,6 mm à Ø 0,8 mm
 Adattatore da Ø 1,6 mm a Ø 0,8 mm

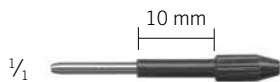

80-533-01-04 max. 50 V_p

Adapter von Ø 1,6 mm auf Ø 0,8 mm
 Adapter from Ø 1.6 mm to Ø 0.8 mm
 Adaptador de Ø 1,6 mm a Ø 0,8 mm
 Adaptateur de Ø 1,6 mm à Ø 0,8 mm
 Adattatore da Ø 1,6 mm a Ø 0,8 mm

Elektrodenbehälter
Containers for electrodes
Contenedores para electrodos
Boîtes pour électrodes
Contenitori per elettrodi

Monopolare Elektroden
Monopolar electrodes
Electrodos monopolares
Electrodes monopolaires
Elettrodi monopolari



2



80-408-00-01*

für 8 Elektroden mit Schaft Ø 4 mm
for 8 electrodes with shaft Ø 4 mm
para 8 electrodos con vástago de Ø de 4 mm
pour 8 électrodes à tige de Ø 4 mm
per 8 elettrodi con asta di Ø 4 mm



80-444-08-01*

für 8 Elektroden mit Schaft Ø 1,6 mm
for 8 electrodes with shaft Ø 1,6 mm
para 8 electrodos con vástago de Ø de 1,6 mm
pour 8 électrodes à tige de Ø 1,6 mm
per 8 elettrodi con asta di Ø 1,6 mm



80-416-00-01*

für 16 Elektroden mit Schaft Ø 4 mm
for 16 electrodes with shaft Ø 4 mm
para 16 electrodos con vástago de Ø de 4 mm
pour 16 électrodes à tige de Ø 4 mm
per 16 elettrodi con asta di Ø 4 mm



55-803-70-04

277 x 172 x 29 mm

Lagerungsset für monopolare Elektroden Ø 1,6, 2,4 und 4 mm
Storage rack for monopolar electrodes Ø 1,6, 2,4 and 4 mm
Almacenaje por electrodos monopolares Ø 1,6, 2,4 y 4 mm
Rangement pour électrodes monopolaires Ø 1,6, 2,4 et 4 mm
Supporto per elettrodi monopolari Ø 1,6, 2,4 e 4 mm

* Autoklavierbar bei 134 °C
Autoclavable at 134°C
Autoclavable a 134 °C
Peut passer à l'autoclave à 134 °C
Autoclavabile a 134 °C

Isolit-Pinzetten
 Isolit forceps
 Pinzas Isolit
 Pince Isolit
 Pinze Isolit



80-285-40-04 80-285-50-04 **max. 4000 V_p**
 4 m/13 ft. 5 m/16 ft.

Anschlusskabel für Isolit-Pinzetten und Zubehör aus unserem früheren Geräteprogramm

Connection cable for Isolit forceps and older KLS Martin instruments (former product line)

Cable de conexión para pinzas Isolit e instrumentos de nuestra anterior gama de equipos

Câble de raccordement pour des pince Isolit et pour des instruments de notre ancien programme d'appareils

Cavo di connessione per pinze Isolit e strumenti del nostro precedente programma degli apparecchi



80-285-55-04 **max. 4000 V_p**
 4 m/13 ft.

Anschlusskabel für Isolit-Pinzetten, mit 3-Pin-Stecker

Connecting cable for Isolit forceps, with 3-pin plug

Cable de conexión para pinzas Isolit, con clavija de tres patillas

Câble de raccordement pour pince Isolit, avec fiche à 3 broches

Cavo di collegamento per pinzette Isolit, con spina a 3 pin



83-124-52-04 **max. 4000 V_p**
 4 m/13 ft.

maXium® i, ME MB 3 i, ME MB 2 i und Valleylab-Geräte → für Isolit-Pinzetten

maXium® i, ME MB 3 i, ME MB 2 i and Valleylab units → for Isolit forceps

maXium® i, ME MB 3 i, ME MB 2 i y aparatos Valleylab → para pinzas Isolit

maXium® i, ME MB 3 i, ME MB 2 i et appareils Valleylab → pour des pince Isolit

maXium® i, ME MB 3 i, ME MB 2 i e apparecchi Valleylab → per pinze Isolit

max. 500 V_p

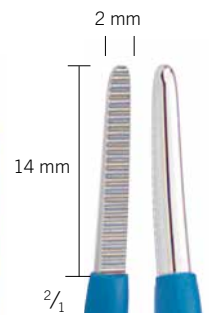
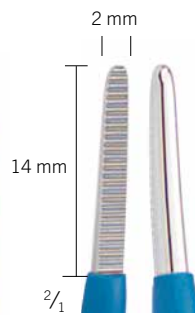

1 x 2
 Zähne
 teeth
 dientes
 denti

Kontaktbereich zur monopolaren Klemmenkoagulation

Contact area for monopolar forceps coagulation

Área de contacto para la coagulación monopolar con pinzas

Zone de contact pour coagulation par pince monopolaire

Zona di contatto per la coagulazione con pinza monopolare



80-900-18-03 = 18 cm/7"
 80-900-21-03 = 21 cm/8 ¼"
 80-900-25-03 = 25 cm/10"

ohne Buchse
 without socket
 sin conexión
 sans prise
 senza presa

80-901-18-03 = 18 cm/7"
 80-901-21-03 = 21 cm/8 ¼"
 80-901-25-03 = 25 cm/10"

ohne Buchse
 without socket
 sin conexión
 sans prise
 senza presa

80-902-18-03 = 18 cm/7"
 80-902-21-03 = 21 cm/8 ¼"
 80-902-25-03 = 25 cm/10"

mit Buchse
 with socket
 con conexión
 avec prise
 con presa



83-120-50-04 **max. 4000 V_p**
 5 m/16 ft.
 Anschlusskabel
 Connection cable
 Cable de conexión
 Câble de raccordement
 Cavo di connessione



83-120-51-04 **max. 4000 V_p**
 5 m/16 ft.
 Anschlusskabel
 Connection cable
 Cable de conexión
 Câble de raccordement
 Cavo di connessione

83-520-39-04 **max. 1500 V_p**
 47 cm/18 1/2"
 Hakenelektrode, Ø 5 mm, isoliert,
 Hakenlänge 5 mm
 Hook electrode, Ø 5 mm, insulated,
 hook length 5 mm
 Electrodo de gancho, Ø 5 mm, aislado,
 longitud del gancho 5 mm
 Electrode crochet, Ø 5 mm, isolée,
 longueur du crochet de 5 mm
 Elettrodo ad uncino, Ø 5 mm, isolato,
 lunghezza del gancio 5 mm

Wiederverwendbare Neutralelektroden
Reusable neutral electrodes
Placas neutras reutilizables
Electrodes neutres reutilisables
Elettrodi neutri riutilizzabili

Einmal-Neutralelektroden
Disposable neutral electrodes
Placas neutras desechables
Electrodes neutres a usage unique
Elettrodi neutri monouso

3





**mit 6,3-mm-NE-Stecker
with 6.3-mm NE plug
con clavija de PN de 6,3 mm
avec fiche EN de 6,3 mm
con spina EN da 6,3 mm**

80-342-03-04

4 m/13 ft.

15 x 26 cm

Gummi-Neutralelektrode für Erwachsene,
ungeteilte Kontaktfläche 370 cm²

Rubber neutral electrode for adults,
single contact surface 370 cm²

Placa neutra de goma para adultos,
superficie de contacto no dividida de 370 cm²

Electrode neutre en caoutchouc pour adultes,
surface de contact non divisée de 370 cm²

Elettrodo neutro di gomma per adulti,
superficie integrale di contatto da 370 cm²

80-332-03-04

4 m/13 ft.

8 x 16 cm

Gummi-Neutralelektrode für Kinder,
ungeteilte Kontaktfläche 120 cm²

Rubber neutral electrode for children,
single contact surface 120 cm²

Placa neutra de goma para niños,
superficie de contacto no dividida de 120 cm²

Electrode neutre en caoutchouc pour enfants,
surface de contact non divisée de 120 cm²

Elettrodo neutro di gomma per bambini,
superficie integrale di contatto da 120 cm²



**mit US-NE-Stecker
with US NE plug
con clavija de PN tipo US
avec fiche EN US
con spina EN US**

80-342-04-04

4 m/13 ft.

15 x 26 cm

Gummi-Neutralelektrode für Erwachsene,
ungeteilte Kontaktfläche 370 cm²

Rubber neutral electrode for adults,
single contact surface 370 cm²

Placa neutra de goma para adultos,
superficie de contacto no dividida de 370 cm²

Electrode neutre en caoutchouc pour adultes,
surface de contact non divisée de 370 cm²

Elettrodo neutro di gomma per adulti,
superficie integrale di contatto da 370 cm²

80-342-05-04

4 m/13 ft.

8 x 16 cm

Gummi-Neutralelektrode für Kinder,
ungeteilte Kontaktfläche 120 cm²

Rubber neutral electrode for children,
single contact surface 120 cm²

Placa neutra de goma para niños,
superficie de contacto no dividida de 120 cm²

Electrode neutre en caoutchouc pour enfants,
surface de contact non divisée de 120 cm²

Elettrodo neutro di gomma per bambini,
superficie integrale di contatto da 120 cm²



**mit 6,3-mm-NE-Stecker
with 6.3-mm NE plug
con clavija de PN de 6,3 mm
avec fiche EN de 6,3 mm
con spina EN da 6,3 mm**

80-342-06-04

4 m/13 ft.

15 x 26 cm

Twin-Pad-Zweiflächen-Neutralelektrode, ohne Knöpfe, Kontaktfläche 256 cm², (2 x 80-371-02-04 + 1 x 80-370-50-04/ 80-371-00-04 erforderlich)

Twin-Pad neutral electrode with two contact surfaces (split), without buttons, contact surface 256 cm², (2 x 80-371-02-04 + 1 x 80-370-50-04/ 80-371-00-04 required)

Placa neutra Twin-Pad con dos superficies, sin botones, superficie de contacto de 256 cm², (necesita 2 x 80-371-02-04 + 1 x 80-370-50-04 /80-371-00-04)

Twin-Pad électrode neutre double, réutilisable, sans boutons, surface de contact 256 cm², (nécessite 2 x 80-371-02-04 + 1 x 80-370-50-04 /80-371-00-04)

Twin-Pad piastra neutra con due superfici, senza bottoni, superficie di contatto da 256 cm², (necessario 2 x 80-371-02-04 + 1 x 80-370-50-04/80-371-00-04)



80-371-02-04

Knopf für KLS Martin Twin-Pad 80-342-06-04

Button for KLS Martin Twin-Pad 80-342-06-04

Botón para la KLS Martin Twin-Pad 80-342-06-04

Bouton pour KLS Martin Twin-Pad 80-342-06-04

Bottone per KLS Martin Twin-Pad 80-342-06-04

Hinweis:

Diese Neutralelektrode darf nicht mit den HF-Generatoren maXium®, miniCutter, ME 102 und MD 62 eingesetzt werden!

Notice:

This neutral electrode must not be used with the maXium®, miniCutter, ME 102 and MD 62 HF generators!

Indicación:

¡Esta placa neutra no debe utilizarse con el generadores de AF maXium®, miniCutter, ME 102 y MD 62!

Indication:

Défense d'utiliser cette électrode neutre avec les générateurs HF maXium®, miniCutter, ME 102 et MD 62!

Avvertenza:

questo elettrodo neutro non può essere usato con il generatori AF maXium®, miniCutter, ME 102 e MD 62!



80-370-50-04 = 50 cm/20"

80-371-00-04 = 100 cm/40"

Gummibinden, gelocht

Rubber bands, with holes

Cintas de goma, perforadas

Bandes caoutchouc, perforées

Nastri in gomma, con fori



80-371-01-04

Knopf für Gummibinde

80-370-50-04 + 80-371-00-04

Button for rubber band

80-370-50-04 + 80-371-00-04

Botón para la cinta de goma

80-370-50-04 + 80-371-00-04

Bouton pour bande caoutchouc

80-370-50-04 + 80-371-00-04

Bottone per nastro in gomma

80-370-50-04 + 80-371-00-04



80-372-00-04

Textilband mit Klettverschluss, 90 cm, waschbar bei 60 °C

Textile band with velcro strap, 90 cm, washable at 60°C

Tira auto-adhesiva, 90 cm, lavable a 60 °C

Bande auto-adhésive, 90 cm, lavable à 60 °C

Nastro in velcro, 90 cm, lavabile a 60 °C

Neutralelektroden
Neutral electrodes
Placas neutras
Electrodes neutres
Elettrodi neutri



mit 6,3-mm-NE-Stecker
with 6.3-mm NE plug
con clavija de PN de 6,3 mm
avec fiche EN de 6,3 mm
con spina EN da 6,3 mm

nur zur Verwendung mit Geräten mit einer
max. Ausgangsleistung von 50 W zugelassen (z. B. MD 62)!

only approved for use with units having a
max. output of 50 W (e.g. MD 62)!

¡solo aprobadas para la utilización con aparatos con una
potencia de salida máx. de 50 W (p. ej. MD 62)!

autorisées uniquement pour utilisation avec des appareils
dont la puissance de sortie maximale est de 50 W (par ex. MD62) !

utilizzo ammesso soltanto con apparecchi con
potenza max. d'uscita di 50 W (ad es. MD 62)!

80-310-04-04

Handzylinder-Neutralelektrode mit 4 m Kabel

Hand cylinder neutral electrode with connection
cable of 4 m

Placa neutra en forma de cilindro con cable
de conexión de 4 m

Electrode neutre en forme de cylindre avec
câble de raccordement de 4 m

Elettrodo neutro a forma cilindrica con cavo
di connessione da 4 m



1/3



1/3



1/3

Anschlusskabel für Einmal-Neutralelektroden

Connection cable for disposable neutral
electrodes

Cable de conexión para placas neutras
desechables

Câble de raccordement pour électrodes
neutres à usage unique

Cavo di connessione per elettrodi neutri
monouso

80-294-40-04

4 m/13 ft.

KLS Martin

80-294-43-04

4 m/13 ft.

maXium® e
Erbe

80-294-44-04

5 m/16 ft.

maXium® i
maXium® smart C
ME MB 3 i
ME MB 2 i
Valleylab

Einmal-Neutralelektroden
 Disposable neutral electrodes
 Placas neutras desechables
 Electrodes neutres à usage unique
 Elettrodi neutri monouso

Neutralelektroden
 Neutral electrodes
 Placas neutras
 Electrodes neutres
 Elettrodi neutri

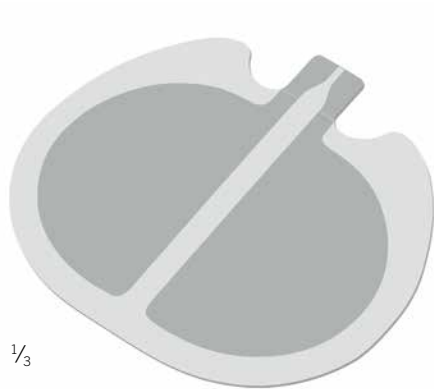

1/3

80-344-09-04

PCS-DuoSafe-Einmal-Neutralelektrode für Erwachsene und Kinder, geteilte Kontaktfläche 107 cm², ohne Anschlusskabel, 50 Stück/VE

PCS DuoSafe disposable neutral electrode for adults and children, split contact surface 107 cm², without connection cable, 50/pack

Placa neutra desechable tipo PCS DuoSafe con dos partes separadas 107 cm² para adultos y niños, sin cable de conexión, 50 piezas/unidad

Électrode neutre à usage unique type PCS DuoSafe avec deux surfaces de contact séparées 107 cm² pour adultes et enfants, sans câble de raccordement, 50 pièces/unité

Elettrodo neutro monouso tipo PCS DuoSafe con due superfici separate 107 cm² per adulti e bambini, senza cavo di connessione, 50 pezzi/unità

3

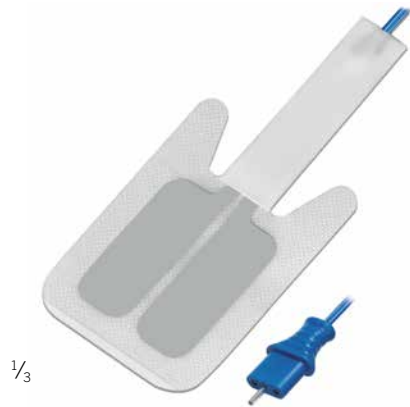

1/3

80-344-12-04

PCS DuoSafe Einmal-Neutralelektrode für Neugeborene und Babies bis max. 5,0 kg Körpergewicht, geteilte Kontaktfläche 33 cm², mit Anschlusskabel International, 10 Stück/VE

PCS DuoSafe disposable neutral electrode for newborns and babies up to a maximum weight of 5.0 kg, split contact surface, 33 cm², with international connecting cable, 10 items/pack

PCS DuoSafe placa neutra desechable para neonatos y bebés hasta un peso máximo de 5,0 kg, superficie de contacto dividida de 33 cm², con cable de conexión internacional, 10 unidades/envase

PCS DuoSafe Électrode neutre à usage unique pour nouveau-nés et bébés dont le poids max. est de 5,0 kg, surface de contact divisée 33 cm², avec câble de raccordement international, 10 pièces/unité

Elettrodo neutro monouso PCS DuoSafe per neonati e bebè fino ad un peso massimo di 5,0 kg, superficie di contatto separata di 33 cm², con cavo di collegamento internazionale, 10 unità/UV



maXium®

Baby

Diese Neutralelektrode darf nur mit dem HF-Gerät **maXium®** (Typ ME 402) ab Hardwarestand 06 sowie Softwarestand größer V 3.404 verwendet werden! Es ist der dafür vorgesehene Baby-NE-Modus zu wählen!

This neutral electrode may only be used with the **maXium®** HF generator (type ME 402) from hardware status 06 and software status higher than V 3.404! The Baby NE mode intended for this neutral electrode must be selected in this case!

¡Esta placa neutra sólo debe utilizarse con el equipo de AF **maXium®** (tipo ME 402) a partir del estado de hardware 06 y con estado de software superior a V 3.404! ¡En todo caso deberá seleccionarse el modo de PN para bebé previsto!

Cette électrode neutre ne peut être utilisée qu'avec l'appareil HF **maXium®** (type ME 402), à partir des versions matérielle HW06 et logicielle supérieure à V3.404 ! Il faut sélectionner le mode EN Bébé prévu à cet effet !

Questo elettrodo neutro può essere usato solo con l'apparecchio AF **maXium®** (tipo ME 402) a partire dalla versione hardware 06 e dalla versione software superiore a V 3.404! In questo caso occorre selezionare la modalità speciale EN per bebè prevista allo scopo!



80-344-11-04 **max. 500 V_p**



Adapter mit internationaler NE-Buchse und 6,3-mm-Stecker

Adapter with international NE socket and 6.3-mm plug





Adaptador con hembra de PN internacional y clavija de 6,3 mm

Adaptateur avec fiche EN internationale et fiche 6,3 mm

Adattatore con presa EN internazionale e spina da 6,3 mm

Art.-Nr. Item No N.º ref. Réf. Codice art.	Gerät Type of unit Tipo del aparato Type d'appareil Tipo d'apparecchio	Gummineutralelektrode Erwachsene Rubber neutral electrode adults Placa neutra de goma adultos Electrode neutre en caoutchouc adultes Elettrodo neutro di gomma adulti (6,3 mm) 80-342-03-04	Gummineutralelektrode Kinder Rubber neutral electrode children Placa neutra de goma niños Electrode neutre en caoutchouc enfants Elettrodo neutro di gomma bambini (6,3 mm) 80-332-03-04	Gummineutralelektrode Erwachsene Rubber neutral electrode adults Placa neutra de goma adultos Electrode neutre en caoutchouc adultes Elettrodo neutro di gomma adulti (US-NE) 80-342-04-04
80-042-00-04	maXium® m	x	x	
80-042-02-04	maXium® i			x
80-042-04-04	maXium® e	x	x	
80-043-00-04	maXium® smart C m			x
80-043-01-04	maXium® smart C i			x
80-043-02-04	maXium® smart C e			x
80-041-01-04	Martin ME 411	x	x	
80-040-00-04	Martin ME 400	x	x	
80-040-11-04	ME MB 3 m	x	x	
80-040-12-04	ME MB 3 i			x
80-010-02-04	Martin ME 102	x	x	
80-008-03-04	miniCutter	x	x	
		 150 x 260 mm	 80 x 100 mm	 150 x 260 mm



Gummineutralelektrode Kinder Rubber neutral electrode children Placa neutra de goma niños Electrode neutre en caoutchouc enfants Elettrodo neutro di gomma bambini (US-NE) 80-342-05-04	Anschlusskabel Einmal-Neutralelektroden Connection cable disposable neutral electrodes Cable de conexión placas neutras desechables Câble de raccordement électrodes neutres à usage unique Cavo di connessione elettrodi neutri monouso			Einmal-Neutralelektrode Disposable neutral electrode Placa neutra desechable Electrode neutre à usage unique Elettrodo neutro monouso 80-344-09-04	Einmal-Neutralelektrode Babies Disposable neutral electrode babies Placa neutra desechable bebés Electrode neutre à usage unique bebés Elettrodo neutro monouso bebé 80-344-12-04 80-344-12-04 + 80-344-11-04	
	X			X		X
X			X	X	X	
		X		X		X
X			X	X	X	
X			X	X	X	
X			X	X	X	
	X			X		
	X			X		
	X			X		
X			X	X		
	X			X		
	X			X		
 <p>80 x 100 mm</p>	 <p>80-294-40-04 80-294-43-04 80-294-44-04</p>				 <p>80-344-12-04</p>  <p>80-344-11-04</p>	

Bipolares Instrumentarium
Bipolar instruments
Instrumentos bipolares
Instruments bipolaires
Strumenti bipolari

4





max. 600 V_p



max. 600 V_p



max. 600 V_p

80-287-33-04 80-287-53-04
 3 m/10 ft. 5 m/16 ft.

KLS-Martin- und Berchtold-Geräte
 → bipolare Instrumente

KLS Martin and Berchtold units
 → bipolar instruments

aparatos KLS Martin y Berchtold
 → instrumentos bipolares

appareils KLS Martin et Berchtold
 → instruments bipolaires

apparecchi KLS Martin e Berchtold
 → strumenti bipolari

80-286-30-04 80-286-50-04
 3 m/10 ft. 5 m/16 ft.

maXium® e / Erbe-Geräte ICC und ACC/VIO
 → bipolare Instrumente

maXium® e / ICC and ACC/VIO Erbe units
 → bipolar instruments

maXium® e / aparatos Erbe ICC e ACC/VIO
 → instrumentos bipolares

maXium® e / appareils Erbe ICC et ACC/VIO
 → instruments bipolaires

maXium® e / apparecchi Erbe ICC e ACC/VIO
 → strumenti bipolari

80-287-89-04 80-287-90-04
 3 m/10 ft. 5 m/16 ft.

maXium® i, ME MB 3 i, ME MB 2 i /Valleylab-Geräte
 → bipolare Instrumente

maXium® i, ME MB 3 i, ME MB 2 i /Valleylab units
 → bipolar instruments

maXium® i, ME MB 3 i, ME MB 2 i / aparatos Valleylab
 → instrumentos bipolares

maXium® i, ME MB 3 i, ME MB 2 i / appareils Valleylab
 → instruments bipolaires

maXium® i, ME MB 3 i, ME MB 2 i / apparecchi Valleylab
 → strumenti bipolari

Standard-Version max. 300 V_p
Standard version
Versión estándar
Version standard
Versione standard

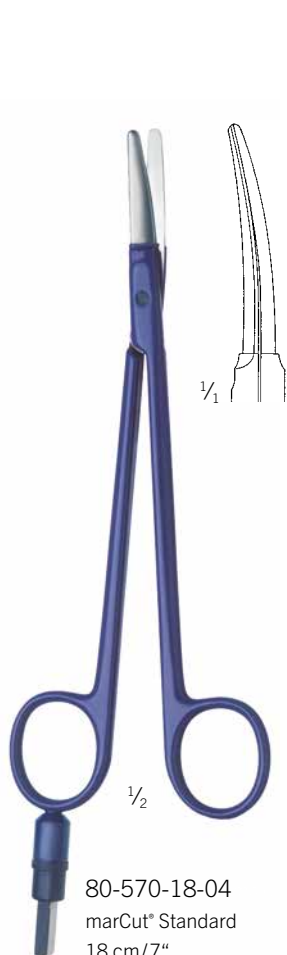

80-570-18-04
 marCut® Standard
 18 cm/7"



80-570-21-04
 marCut® Standard
 21 cm/8 1/4"



80-570-23-04
 marCut® Standard
 23 cm/9"



80-570-28-04
 marCut® Standard
 28 cm/11"



$\frac{1}{3}$ max. 600 V_p

80-287-72-04

5 m/16 ft.

Codman- und Valleylab-Geräte
 → bipolare Instrumente

Codman and Valleylab units
 → bipolar instruments

aparatos Codman y Valleylab
 → instrumentos bipolares

appareils Codman et Valleylab
 → instruments bipolaires

apparecchi Codman e Valleylab
 → strumenti bipolari



80-570-00-04

Protector für die Aufbereitung. Wir empfehlen dringend die Verwendung des Protectors für die Aufbereitung der Schere.

Protector for instrument processing. We strongly recommend using the protector when reprocessing the scissors.

Protector para el tratamiento. Recomendamos encarecidamente la utilización del protector para el tratamiento de las tijeras.

Protecteur pour la préparation. Nous recommandons expressément l'utilisation du protecteur pour la préparation des ciseaux.

Protettore per il trattamento. Si consiglia vivamente l'uso del protettore per il trattamento delle forbici.



Weitere Informationen entnehmen Sie bitte der separaten Broschüre.

For further information please refer to our separate product brochure.

Encontrará informaciones adicionales en el folleto individual.

Vous trouverez des informations supplémentaires dans la brochure.

Per ulteriori informazioni vedasi il prospetto separato.

4

Slim Line

Schlanke Version max. 300 V_p
 Slim model
 Versión delgada
 Version élancée
 Modello sottile



80-571-18-04
 marCut® SL
 18 cm/7"

80-571-21-04
 marCut® SL
 21 cm/8 1/4"

80-571-23-04
 marCut® SL
 23 cm/9"

80-571-28-04
 marCut® SL
 28 cm/11"



80-287-33-04 80-287-53-04
 3 m/10 ft. 5 m/16 ft.

KLS-Martin- und Berchtold-Geräte
 → bipolare Instrumente

KLS Martin and Berchtold units
 → bipolar instruments

aparatos KLS Martin y Berchtold
 → instrumentos bipolares

appareils KLS Martin et Berchtold
 → instruments bipolaires

apparecchi KLS Martin e Berchtold
 → strumenti bipolari



80-286-30-04 80-286-50-04
 3 m/10 ft. 5 m/16 ft.

maXium® e / Erbe-Geräte ICC und ACC/VIO
 → bipolare Instrumente

maXium® e / ICC and ACC/VIO Erbe units
 → bipolar instruments

maXium® e / aparatos Erbe ICC e ACC/VIO
 → instrumentos bipolares

maXium® e / appareils Erbe ICC et ACC/VIO
 → instruments bipolaires

maXium® e / apparecchi Erbe ICC e ACC/VIO
 → strumenti bipolari



80-287-89-04 80-287-90-04
 3 m/10 ft. 5 m/16 ft.

maXium® i, ME MB 3 i, ME MB 2 i / Valleylab-Geräte
 → bipolare Instrumente

maXium® i, ME MB 3 i, ME MB 2 i / Valleylab units
 → bipolar instruments

maXium® i, ME MB 3 i, ME MB 2 i / aparatos Valleylab
 → instrumentos bipolares

maXium® i, ME MB 3 i, ME MB 2 i / appareils Valleylab
 → instruments bipolaires

maXium® i, ME MB 3 i, ME MB 2 i / apparecchi Valleylab
 → strumenti bipolari

Super Slim Line

Superschlanke Version max. 300 V_p
Super slim model
Versión super delgada
Version super mince
Versione extra snella

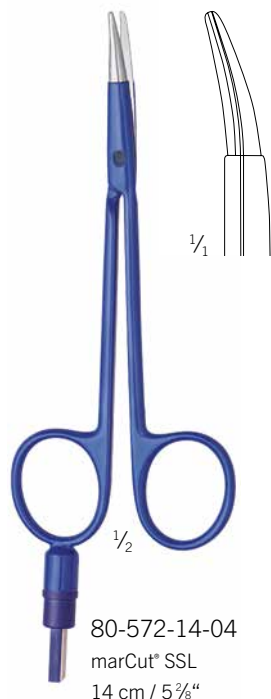



80-287-72-04
 5 m/16 ft.

Codman- und Valleylab-Geräte
 → bipolare Instrumente
 Codman and Valleylab units
 → bipolar instruments
 aparatos Codman y Valleylab
 → instrumentos bipolares
 appareils Codman et Valleylab
 → instruments bipolaires
 apparecchi Codman e Valleylab
 → strumenti bipolari



80-570-00-04

Protector für die Aufbereitung. Wir empfehlen dringend die Verwendung des Protectors für die Aufbereitung der Schere.
 Protector for instrument processing. We strongly recommend using the protector when reprocessing the scissors.
 Protector para el tratamiento. Recomendamos encarecidamente la utilización del protector para el tratamiento de las tijeras.
 Protecteur pour la préparation. Nous recommandons expressément l'utilisation du protecteur pour la préparation des ciseaux.
 Protettore per il trattamento. Si consiglia vivamente l'uso del protettore per il trattamento delle forbici.



Weitere Informationen entnehmen Sie bitte der separaten Broschüre.
 For further information please refer to our separate product brochure.
 Encontrará informaciones adicionales en el folleto individual.
 Vous trouverez des informations supplémentaires dans la brochure.
 Per ulteriori informazioni vedasi il prospetto separato.

4



mit geradem Stecker
 with straight plug
 con clavija recta
 avec fiche droite
 con spina diritta



Weitere Informationen entnehmen Sie bitte der separaten Broschüre.
 For further information please refer to our separate product brochure.
 Encontrará informaciones adicionales en el folleto individual.
 Vous trouverez des informations supplémentaires dans la brochure.
 Per ulteriori informazioni vedasi il prospetto separato.

max. 500 V_p

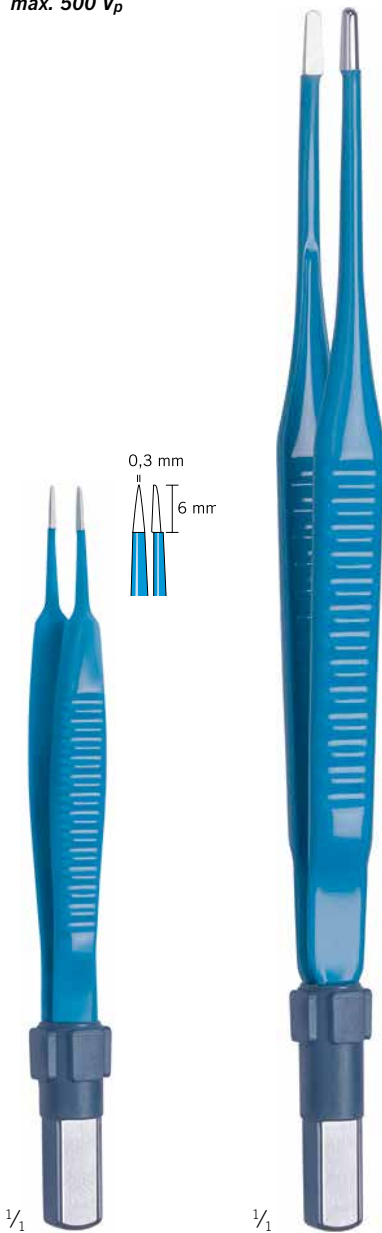

80-910-07-04
 8,5 cm / 3 1/4"
 spitz, 0,3 mm
 pointed, 0,3 mm
 puntiaguda, 0,3 mm
 pointue, 0,3 mm
 acuta, 0,3 mm

Beispielabbildung
 Example illustration
 Ilustración a modo de ejemplo
 Illustration à titre d'exemple
 Figura di esempio

Bipolare Pinzetten, gerade
Bipolar forceps, straight
Pinzas bipolares, rectas
Pincas bipolaires, droites
Pinze bipolarari, diritte

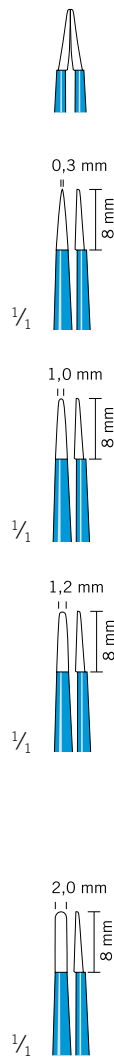

Spitzenbreite Tip width Ancho de la punta Largeur des pointes Larghezza delle punte	Länge Length Longitud Longueur Lunghezza	Artikel-Nr. Item No. N.º referencia Référence Codice articolo
---	--	---

spitz/pointed/puntiaguda/pointue/acuta

0,3 mm	12 cm / 4 3/4"	80-910-12-04
0,3 mm	16 cm / 6 1/4"	80-910-16-04
0,3 mm	18 cm / 7"	80-910-18-04
0,3 mm	20 cm / 8"	80-910-20-04
0,3 mm	22 cm / 8 3/4"	80-910-22-04

stumpf/blunt/roma/mousse/smussa

1,0 mm	12 cm / 4 3/4"	80-924-12-04
--------	----------------	--------------

stumpf/blunt/roma/mousse/smussa

1,2 mm	16 cm / 6 1/4"	80-924-16-04
1,2 mm	18 cm / 7"	80-924-18-04
1,2 mm	20 cm / 8"	80-924-20-04
1,2 mm	22 cm / 8 3/4"	80-924-22-04
1,2 mm	24 cm / 9 1/2"	80-924-24-04
1,2 mm	26 cm / 10 1/4"	80-924-26-04
1,2 mm	30 cm / 11 3/4"	80-924-30-04

stumpf/blunt/roma/mousse/smussa

2,0 mm	12 cm / 4 3/4"	80-934-12-04
2,0 mm	16 cm / 6 1/4"	80-934-16-04
2,0 mm	18 cm / 7"	80-934-18-04
2,0 mm	20 cm / 8"	80-934-20-04
2,0 mm	22 cm / 8 3/4"	80-934-22-04
2,0 mm	24 cm / 9 1/2"	80-934-24-04
2,0 mm	26 cm / 10 1/4"	80-934-26-04
2,0 mm	30 cm / 11 3/4"	80-934-30-04



max. 500 V_p

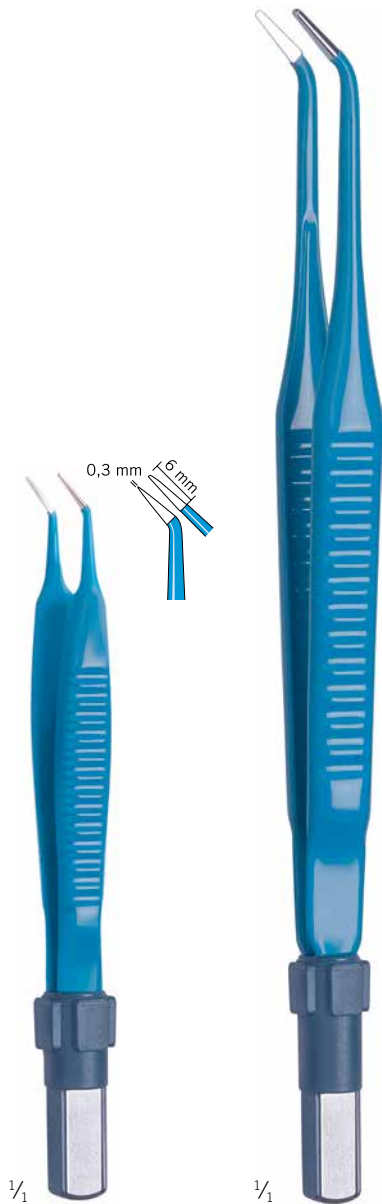

80-911-07-04
 8,5 cm/3 1/4"
 spitz, 0,3 mm
 pointed, 0,3 mm
 puntiaguda, 0,3 mm
 pointue, 0,3 mm
 acuta, 0,3 mm

Beispielabbildung
 Example illustration
 Ilustración a modode ejemplo
 Illustration à titred'exemple
 Figura di esempio

Bipolare Pinzetten, gewinkelt
Bipolar forceps, angled
Pinzas bipolares, acodadas
Pinces bipolaires, coudées
Pinze bipolari, piegate

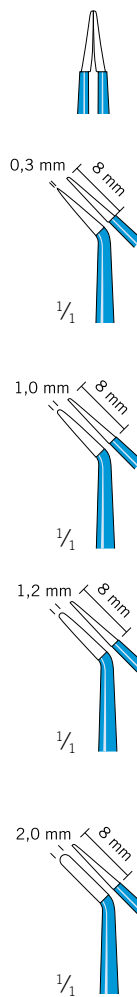

Spitzenbreite Tip width Ancho de la punta Largeur des pointes Larghezza delle punte	Länge Length Longitud Longueur Lunghezza	Artikel-Nr. Item No. N.º referencia Référence Codice articolo
---	--	---

spitz/pointed/puntiaguda/pointue/acuta

0,3 mm	12 cm/4 3/4"	80-911-12-04
0,3 mm	16 cm/6 1/4"	80-911-16-04
0,3 mm	18 cm/7"	80-911-18-04
0,3 mm	20 cm/8"	80-911-20-04

stumpf/blunt/roma/mousse/smussa

1,0 mm	12 cm/4 3/4"	80-925-12-04
--------	--------------	--------------

stumpf/blunt/roma/mousse/smussa

1,2 mm	16 cm/6 1/4"	80-925-16-04
1,2 mm	18 cm/7"	80-925-18-04
1,2 mm	20 cm/8"	80-925-20-04
1,2 mm	22 cm/8 3/4"	80-925-22-04



stumpf/blunt/roma/mousse/smussa

2,0 mm	16 cm/6 1/4"	80-935-16-04
2,0 mm	18 cm/7"	80-935-18-04
2,0 mm	20 cm/8"	80-935-20-04
2,0 mm	22 cm/8 3/4"	80-935-22-04
2,0 mm	24 cm/9 1/2"	80-935-24-04

max. 500 V_p

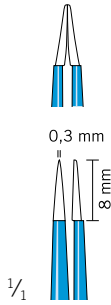

Beispielabbildung
 Example illustration
 Ilustración a modo de ejemplo
 Illustration à titre d'exemple
 Figura di esempio

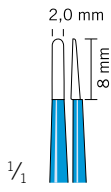
Bipolare Pinzetten, bajonettförmig Bipolar forceps, bayonet-shaped Pinzas bipolares, bayoneta Pincas bipolaires à baïonnette Pinze bipolari, baionetta			
	Spitzenbreite Tip width Ancho de la punta Largeur des pointes Larghezza delle punte	Länge Length Longitud Longueur Lunghezza	Artikel-Nr. Item No. N.º referencia Référence Codice articolo
 <p>0,3 mm 8 mm 1/1</p>	spitz/pointed/puntiaguda/pointue/acuta		
	0,3 mm	16 cm/6 1/4"	80-931-16-04
	0,3 mm	18 cm/7"	80-931-18-04
	0,3 mm	20 cm/8"	80-931-20-04
 <p>1,2 mm 8 mm 1/1</p>	stumpf/blunt/roma/mousse/smussa		
	1,2 mm	16 cm/6 1/4"	80-945-16-04
	1,2 mm	18 cm/7"	80-945-18-04
	1,2 mm	20 cm/8"	80-945-20-04
 <p>2,0 mm 8 mm 1/1</p>	stumpf/blunt/roma/mousse/smussa		
	2,0 mm	18 cm/7"	80-948-18-04
	2,0 mm	20 cm/8"	80-948-20-04
	2,0 mm	24 cm/9 1/2"	80-948-24-04
	2,0 mm	30 cm/11 3/4"	80-948-30-04



max. 500 V_p

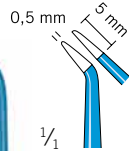
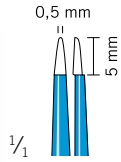

1/1

1/1

80-950-20-04
 20 cm/8"

80-951-20-04
 20 cm/8"

Geräte Units Equipos Appareils Apparecchi	Instrumente Instruments Instrumentos Instruments Strumenti	Europäischer Flachstecker, rund European flat plug, round Enchufe plano para Europa, redondo Fiche plate européenne, ronde Spina piatta europea, rotonda	
		max. 600 V _p	max. 850 V _p
KLS Martin Berchtold Aesculap		80-287-33-04 3 m/10 ft.	80-291-40-04 4 m/13 ft.
		80-287-53-04 5 m/16 ft.	
maXium® e Erbe ICC Erbe ACC Erbe VIO		80-286-30-04 3 m/10 ft.	80-286-40-04 4 m/13 ft.
		80-286-50-04 5 m/16 ft.	
maXium® i maXium® e ME MB 2 i ME MB 3 i Valleylab		80-287-89-04 3 m/10 ft.	80-293-40-04 4 m/13 ft.
		80-287-90-04 5 m/16 ft.	
Codman Valleylab		80-287-72-04 5 m/16 ft.	



mit geradem Stecker
 with straight plug
 con clavija recta
 avec fiche droite
 con spina diritta

mit abgewinkeltem Stecker
 with angled plug
 con clavija acodada
 avec fiche coudée
 con spina piegata

4

Modellvielfalt

Alle gängigen Abmessungen für unterschiedliche Anwendungen

Variety of models

All common dimensions for different applications

Diversidad de modelos

Todas las dimensiones habituales para diferentes aplicaciones

De nombreux modèles

Toutes les dimensions courantes pour applications diverses

Molteplicità di modelli

Tutte le dimensioni di uso comune per le diverse applicazioni

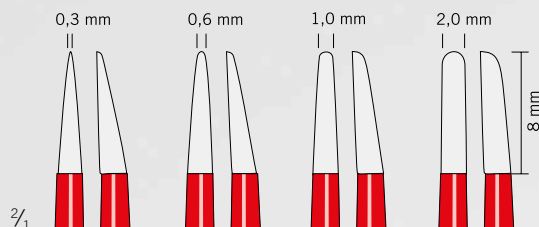

Pinzettenspitzen

- Polierte Edelmetallspitzen
- Kein Anhaften von Gewebe

The tips of the forceps

- Polished noble metal tips
- No tissue sticking to the tips

Las puntas de la pinza

- Puntas de metal noble pulidas
- Sin adherencias del tejido

Pointes de la pince

- Pointes polies en métal précieux
- Les tissus n'adhèrent pas aux pointes

Punte delle pinze

- Punte lucidate in metallo prezioso
- Nessuna adesione al tessuto



marSIGHT-Geometrie

- Maximale Sicht auf das OP-Feld
- Punktgenaues Fassen von Gewebe

marSIGHT geometry

- Maximum view of the surgical site
- High-precision grasping of tissue

Geometría marSIGHT

- Visibilidad máxima sobre el campo operatorio
- Aprisionado del tejido con precisión puntual

Géométrie marSIGHT

- Visibilité maximale sur le champ opératoire
- Saisie ponctuelle de tissu

Geometria marSIGHT

- Massima visibilità dal campo operatorio
- Afferraggio di alta precisione del tessuto





revolutionary ergonomic design

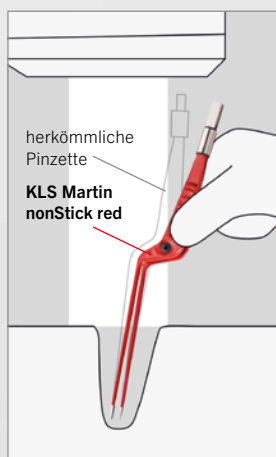
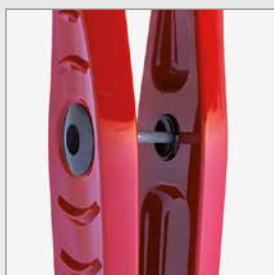

- Integrierte Pinzettenführung
- Integrated guiding mechanism
- Mecanismo de guiado integrado
- Mécanisme de guidage intégré
- Meccanismo di guida integrato

- Europäischer Flachpin-Stecker
- European flat-pin plug
- Clavija europea de pin plano
- Fiche européenne à broche plate
- Spina europea a pin piatto

- Ergonomische Grifffläche für ermüdungsfreies Arbeiten
- Ergonomic handle surface prevents fatigue in the surgeon's hand
- La superficie ergonómica del mango evita la fatiga en la mano del cirujano
- Surface de la poignée ergonomique pour un travail sans fatigue
- Superficie ergonomica dell'impugnatura per lavorare senza fatica

- Sichtoptimierte Schenkelgeometrie für die Anwendung unter dem OP-Mikroskop
- View-optimized shank geometry for applications under the operating microscope
- Geometría optimizada de las ramas en pro de la visibilidad para la aplicación bajo el microscopio quirúrgico
- Géométrie des branches optimisée pour une visibilité accrue sous le microscope opératoire
- Geometria delle branche a visibilità perfezionata per applicazione sotto il microscopio operatorio

Bipolare Pinzetten, nonStick red
 Bipolar forceps, nonStick red
 Pinzas bipolares, nonStick red
 Pincas bipolares, nonStick red
 Pinze bipolari, nonStick red

nonStick red

revolutionary
 ergonomic
 design

max. 500 V_p



1/1



1/1

80-982-12-04
 12 cm/4 3/4"
 spitz, 0,3 mm
 pointed, 0,3 mm
 puntiaguda, 0,3 mm
 pointue, 0,3 mm
 acuta, 0,3 mm

Beispielabbildung
 Example illustration
 Ilustración a modo de ejemplo
 Illustration à titre d'exemple
 Figura di esempio

Bipolare Pinzetten, gerade
 Bipolar forceps, straight
 Pinzas bipolares, rectas
 Pincas bipolares, droites
 Pinze bipolari, diritte

marSIGHT

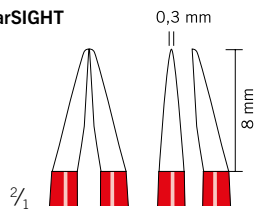

marSIGHT

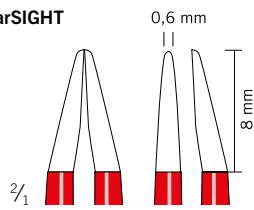

Standard

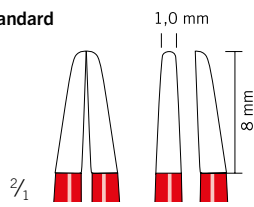

Standard

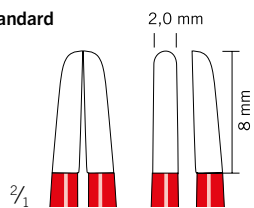

Spitzenbreite Tip width Ancho de la punta Largeur des pointes Larghezza delle punte	Länge Length Longitud Longueur Lunghezza	Artikel-Nr. Item No. N.º referencia Référence Codice articolo
---	--	---

spitz/pointed/puntiaguda/pointue/acuta

0,3 mm	12 cm/4 3/4"	80-982-12-04
0,3 mm	17 cm/6 1/4"	80-982-17-04
0,3 mm	20 cm/8"	80-982-20-04
0,3 mm	23 cm/9"	80-982-23-04

stumpf/blunt/roma/mousse/smussa

0,6 mm	12 cm/4 3/4"	80-984-12-04
0,6 mm	17 cm/6 1/4"	80-984-17-04
0,6 mm	20 cm/8"	80-984-20-04

stumpf/blunt/roma/mousse/smussa

1,0 mm	12 cm/4 3/4"	80-986-12-04
1,0 mm	17 cm/6 1/4"	80-986-17-04
1,0 mm	20 cm/8"	80-986-20-04
1,0 mm	23 cm/9"	80-986-23-04

stumpf/blunt/roma/mousse/smussa

2,0 mm	17 cm/6 1/4"	80-988-17-04
2,0 mm	20 cm/8"	80-988-20-04
2,0 mm	23 cm/9"	80-988-23-04
2,0 mm	30 cm/11 3/4"	80-988-30-04



max. 500 V_p



1/1

1/1

Bipolare Pinzetten, gewinkelt
 Bipolar forceps, angled
 Pinzas bipolares, acodadas
 Pincas bipolaires, coudées
 Pinze bipolari, piegate

Standard

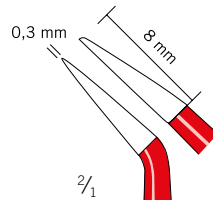

2/1

Standard

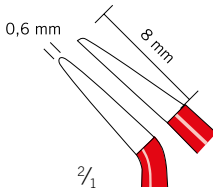

2/1

Standard

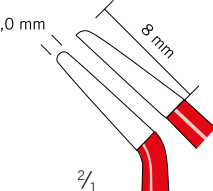

2/1

Standard

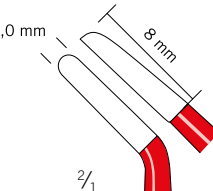

2/1

Spitzenbreite Tip width Ancho de la punta Largeur des pointes Larghezza delle punte	Länge Length Longitud Longueur Lunghezza	Artikel-Nr. Item No. N.º referencia Référence Codice articolo
---	--	---

spitz/pointed/puntiaguda/pointue/acuta

0,3 mm	12 cm/4 3/4"	80-983-12-04
0,3 mm	17 cm/6 1/4"	80-983-17-04

stumpf/blunt/roma/mousse/smussa

0,6 mm	12 cm/4 3/4"	80-985-12-04
0,6 mm	17 cm/6 1/4"	80-985-17-04
0,6 mm	20 cm/8"	80-985-20-04

stumpf/blunt/roma/mousse/smussa

1,0 mm	12 cm/4 3/4"	80-987-12-04
1,0 mm	17 cm/6 1/4"	80-987-17-04
1,0 mm	20 cm/8"	80-987-20-04
1,0 mm	23 cm/9"	80-987-23-04

stumpf/blunt/roma/mousse/smussa

2,0 mm	17 cm/6 1/4"	80-989-17-04
2,0 mm	20 cm/8"	80-989-20-04
2,0 mm	23 cm/9"	80-989-23-04
2,0 mm	25 cm/9 3/4"	80-989-25-04
2,0 mm	28 cm/11"	80-989-28-04
2,0 mm	30 cm/11 3/4"	80-989-30-04

80-983-12-04

12 cm/4 3/4"

spitz, 0,3 mm
 pointed, 0,3 mm
 puntiaguda, 0,3 mm
 pointue, 0,3 mm
 acuta, 0,3 mm

Beispielabbildung
 Example illustration
 Ilustración a modo de ejemplo
 Illustration à titre d'exemple
 Figura di esempio

KLS Martin **nonStick** red –

die bipolaren Pinzetten von KLS Martin mit ANTIHAFTEFFEKT und revolutionärer Ergonomie
 the bipolar forceps from KLS Martin – with nonStick effect and a revolutionary ergonomic design
 las pinzas bipolares de KLS Martin con efecto ANTIADHERENTE y ergonomía revolucionaria
 les pincas bipolaires de KLS Martin à effet ANTI-ADHÉSIF et ergonomie révolutionnaire
 le pinze bipolari di KLS Martin con effetto ANTIADERENTE ed ergonomía rivoluzionaria

Bipolare Pinzetten, nonStick red
 Bipolar forceps, nonStick red
 Pinzas bipolares, nonStick red
 Pincers bipolaires, nonStick red
 Pinze bipolari, nonStick red

nonStick red

revolutionary
 ergonomic
 design

max. 500 V_p



1/1

Beispielabbildung
 Example illustration
 Ilustración a modo de ejemplo
 Illustration à titre d'exemple
 Figura di esempio

Bipolare Pinzetten, bajonettförmig
 Bipolar forceps, bayonet-shaped
 Pinzas bipolares, bayoneta
 Pincers bipolaires, à baïonnette
 Pinze bipolari, baionetta

	Spitzenbreite Tip width Ancho de la punta Largeur des pointes Larghezza delle punte	Länge Length Longitud Longueur Lunghezza	Artikel-Nr. Item No. N.º referencia Référence Codice articolo
marSIGHT 	spitz/pointed/puntiaguda/pointue/acuta		
	0,3 mm	17 cm/6 1/4"	80-990-17-04
	0,3 mm	20 cm/8"	80-990-20-04
	0,3 mm	23 cm/9"	80-990-23-04
marSIGHT 	stumpf/blunt/roma/mousse/smuša		
	0,6 mm	17 cm/6 1/4"	80-991-17-04
	0,6 mm	20 cm/8"	80-991-20-04
	0,6 mm	23 cm/9"	80-991-23-04
Standard 	stumpf/blunt/roma/mousse/smuša		
	1,0 mm	17 cm/6 1/4"	80-992-17-04
	1,0 mm	20 cm/8"	80-992-20-04
	1,0 mm	23 cm/9"	80-992-23-04
Standard 	stumpf/blunt/roma/mousse/smuša		
	2,0 mm	17 cm/6 1/4"	80-993-17-04
	2,0 mm	20 cm/8"	80-993-20-04
	2,0 mm	23 cm/9"	80-993-23-04

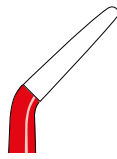

nach oben gewinkelt
 upward-bent
 acodada hacia arriba
 coudée vers le haut
 piegata in alto

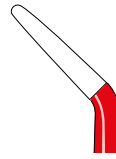

nach unten gewinkelt
 downward-bent
 acodada hacia abajo
 coudée vers le bas
 piegata in basso

Bipolare Pinzetten, bajonettförmig, gewinkelt
Bipolar forceps, bayonet-shaped, angled
Pinzas bipolares, bayoneta, acodadas
Pinces bipolaires, à baïonnette, coudées
Pinze bipolari, baionetta, piegate

Standard

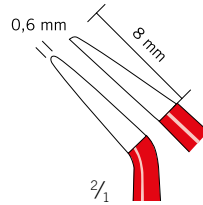

Spitzenbreite Tip width Ancho de la punta Largeur des pointes Larghezza delle punte	Länge Length Longitud Longueur Lunghezza	Artikel-Nr. Item No. N.º referencia Référence Codice articolo
---	--	---

stumpf/blunt/roma/mousse/smussa

0,6 mm	23 cm/9"	80-997-23-04
0,6 mm	25 cm/9 3/4"	80-997-25-04

Standard

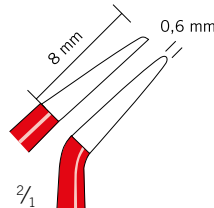

stumpf/blunt/roma/mousse/smussa

0,6 mm	23 cm/9"	80-996-23-04
0,6 mm	25 cm/9 3/4"	80-996-25-04

Standard

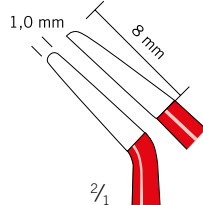

stumpf/blunt/roma/mousse/smussa

1,0 mm	20 cm/8"	80-994-20-04
1,0 mm	23 cm/9"	80-994-23-04
1,0 mm	25 cm/9 3/4"	80-994-25-04

Standard

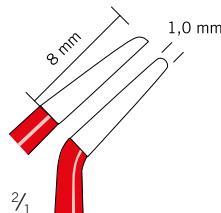

stumpf/blunt/roma/mousse/smussa

1,0 mm	20 cm/8"	80-995-20-04
1,0 mm	23 cm/9"	80-995-23-04
1,0 mm	25 cm/9 3/4"	80-995-25-04

1/1

Beispielabbildung
 Example illustration
 Ilustración a modo de ejemplo
 Illustration à titre d'exemple
 Figura di esempio

KLS Martin **nonStick** red –

die bipolaren Pinzetten von KLS Martin mit ANTIHAFTEFFEKT und revolutionärer Ergonomie
 the bipolar forceps from KLS Martin – with nonStick effect and a revolutionary ergonomic design
 las pinzas bipolares de KLS Martin con efecto ANTIADHERENTE y ergonomía revolucionaria
 les pince bipolaires de KLS Martin à effet ANTI-ADHÉSIF et ergonomie révolutionnaire
 le pinze bipolari di KLS Martin con effetto ANTIADERENTE ed ergonomia rivoluzionaria

Bipolare Pinzetten, nonStick red, gebogen
 Bipolar forceps, nonStick red, curved
 Pinzas bipolares, nonStick red, acodadas
 Pincès bipolaires, nonStick red, courbes
 Pinze bipolari, nonStick red, curve

nonStick red

max. 500 V_p











80-998-23-04
23 cm/9"

80-999-23-04
23 cm/9"

80-999-24-04
23 cm/9"

Meuser
80-998-24-04
18 cm/7"



<p>Geräte Units Equipos Appareils Apparecchi</p>	<p>Instrumente Instruments Instrumentos Strumenti</p>	<p>Europäischer Flachstecker, rund European flat plug, round Enchufe plano para Europa, redondo Fiche plate européenne, ronde Spina piatta europea, rotonda</p> <p>max. 600 V_p max. 850 V_p</p>  <p>1/3</p>	
<p>KLS Martin Berchtold Aesculap</p>  		<p>80-287-33-04 3 m/10 ft.</p>	<p>80-291-40-04 4 m/13 ft.</p>
<p>maXium® e Erbe ICC Erbe ACC Erbe VIO</p>  		<p>80-286-30-04 3 m/10 ft.</p> <p>80-286-50-04 5 m/16 ft.</p>	<p>80-286-40-04 4 m/13 ft.</p>
<p>maXium® i maXium® e ME MB 2 i ME MB 3 i Valleylab</p>  		<p>80-287-89-04 3 m/10 ft.</p> <p>80-287-90-04 5 m/16 ft.</p>	<p>80-293-40-04 4 m/13 ft.</p>
<p>Codman Valleylab</p>  		<p>80-287-72-04 5 m/16 ft.</p>	



mit geradem Stecker
 with straight plug
 con clavija recta
 avec fiche droite
 con spina diritta



mit abgewinkeltem Stecker
 with angled plug
 con clavija acodada
 avec fiche coudée
 con spina piegata



Weitere Informationen entnehmen Sie bitte der separaten Broschüre.

For further information please refer to our separate product brochure.

Encontrará informaciones adicionales en el folleto individual.

Vous trouverez des informations supplémentaires dans la brochure.

Per ulteriori informazioni vedasi il prospetto separato.

Bipolare Pinzetten, nonStick red
 Bipolar forceps, nonStick red
 Pinzas bipolares, nonStick red
 Pincas bipolaires, nonStick red
 Pinze bipolari, nonStick red

nonStick red

revolutionary
 ergonomic
 design

Lagerung und Transport

Für die sichere Lagerung und den Transport der bipolaren nonStick-red-Pinzetten kann das neue Siebkorbssystem von KLS Martin verwendet werden.

Storage and transport

To store and transport your nonStick red forceps safely and securely, we recommend using the new KLS Martin mesh tray system.

Almacenaje y transporte

Para el almacenaje y transporte seguros de las pinzas bipolares nonStick red puede utilizarse el nuevo sistema de bandejas cribadas de KLS Martin.

Stockage et transport

Le nouveau système de paniers à mailles de KLS Martin garantit la fiabilité des stockage et transport des pincas bipolaires nonStick red.

Magazzinaggio e trasporto

Per il magazzinaggio e trasporto sicuri delle pinze bipolari nonStick red è possibile usare il nuovo sistema di vassoi reticolati di KLS Martin.

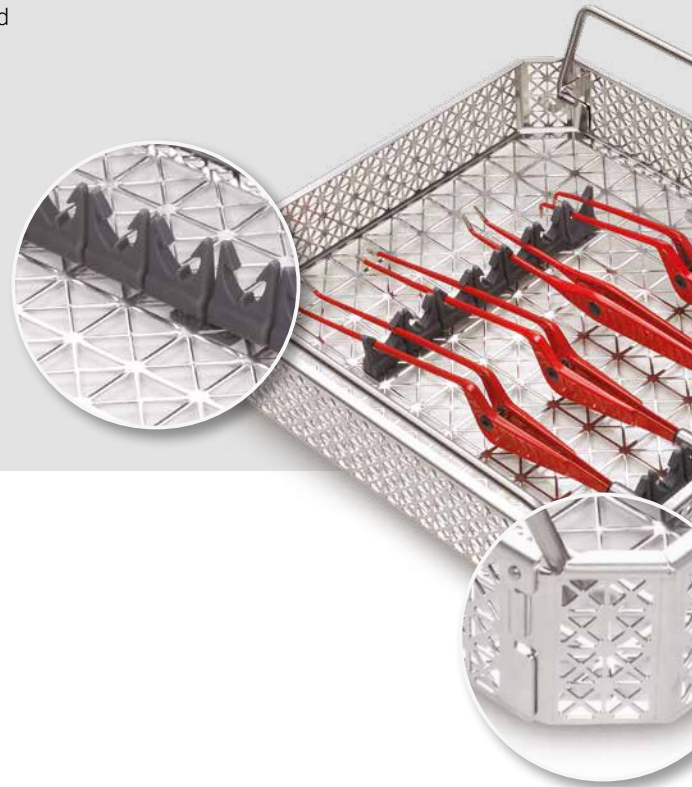

	Für Pinzetten mit einer maximalen Länge von 23 cm schlagen wir folgende Konfiguration vor:		For forceps with a maximum length of 23 cm, we recommend the following configuration:		Para pinzas con una longitud máxima de 23 cm proponemos la siguiente configuración:	
	Artikelbeschreibung	Menge	Designation	Quantity	Descripción del artículo	Cantidad
55-804-25-01	Siebkorb, 243 x 255 x 53 mm	1	Mesh tray, 243 x 255 x 53 mm	1	Bandeja cribada, 243 x 255 x 53 mm	1
55-805-28-01	Deckel, 243 x 255 mm	1	Lid, 243 x 255 mm	1	Tapa, 243 x 255 mm	1
	Fixierelemente		Fixing elements		Elementos de fijación	
55-806-02-04	Clip für Fixierelement (VE = 10 Stück)	1	Clip for fixing element (10/pack)	1	Clip para elemento de fijación (UE = 10 ud.)	1
55-806-07-04	Fixierelement (VE = 6 Stück)	2	Fixing element (6/pack)	2	Elemento de fijación (UE = 6 ud.)	2

	Für Pinzetten größer 23 cm sollte ein ¾-Siebkorb verwendet werden:		For forceps longer than 23 cm, a ¾-size tray should be used.		For forceps longer than 23 cm, a ¾-size tray should be used.	
	Artikelbeschreibung	Menge	Designation	Quantity	Descripción del artículo	Cantidad
55-804-42-01	Siebkorb, 410 x 255 x 53 mm	1	Mesh tray, 410 x 255 x 53 mm	1	Mesh tray, 410 x 255 x 53 mm	1
55-805-45-01	Deckel, 410 x 255 mm	1	Lid, 410 x 255 mm	1	Lid, 410 x 255 mm	1
	Fixierelemente		Fixing elements		Elementos de fijación	
55-806-02-04	Clip für Fixierelement (VE = 10 Stück)	1	Clip for fixing element (10/pack)	1	Clip for fixing element (10/pack)	1
55-806-07-04	Fixierelement (VE = 6 Stück)	2	Fixing element (6/pack)	2	Fixing element (6/pack)	2



Beispiel Bestückung
 Equipment example
 Ejemplo de dotación
 Exemple chargement
 Esempio di allestimento



Fixierelemente werden in zusammenhängenden 6er-Einheiten mit drei Halteclips geliefert. Sie können jedoch problemlos mit einer Schere die Einheit trennen – ganz wie Sie es brauchen.

Fixing elements are available as 6-item strips with three holding clips. However, you can easily cut up the strips with a pair of scissors – just as you need it.

Los elementos de fijación se suministran en unidades continuas de 6 con tres clips de sujeción. No obstante, usted también puede separar sin problemas la unidad de 6 con unas tijeras, según sus requerimientos personales.

Les éléments de fixation sont livrés par unités de 6 d'un seul tenant, avec trois clips. Il vous suffit de découper ces éléments de fixation avec une paire de ciseaux – en fonction de vos besoins.

Gli elementi di fissaggio vengono forniti in confezioni di sei unità con tre clip. Potete però tagliare l'unità con un paio di forbici in base alle vostre esigenze.

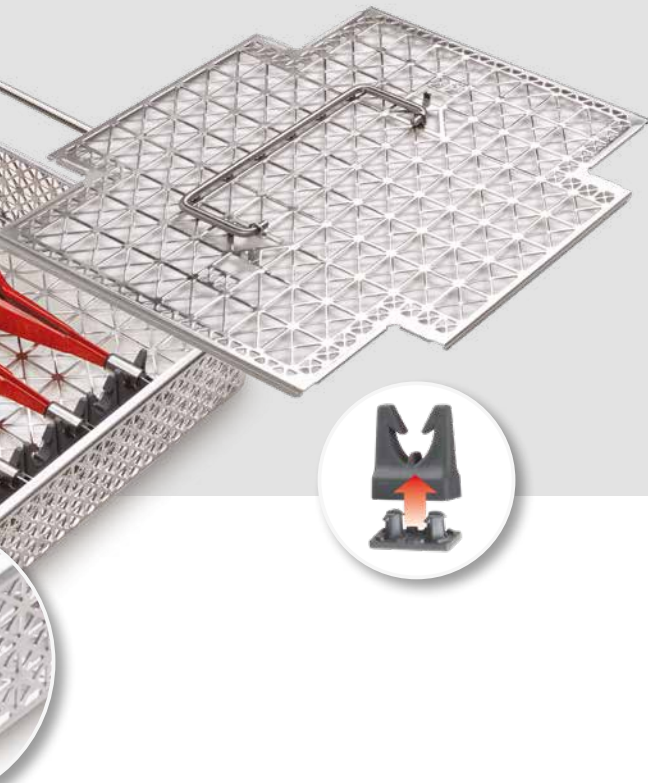

4

	Nous proposons la configuration suivante pour les pinces de 23 cm de long au maximum:		Per pinze della lunghezza massima di 23 cm proponiamo la seguente configurazione:
	Description	Quantité	Designazione
55-804-25-01	Panier à mailles, 243 x 255 x 53 mm	1	Vassoio reticolato, 243 x 255 x 53 mm
55-805-28-01	Couvercle, 243 x 255 mm	1	Coperchio, 243 x 255 mm
	Éléments de fixation		Elementi di fissaggio
55-806-02-04	Clip pour élément de fixation (UE = 10)	1	Clip per elemento di fissaggio (UV=10 pezzi)
55-806-07-04	Élément de fixation (UE = 6)	2	Elemento di fissaggio (UV=6 pezzi)

	Il est recommandé d'utiliser une panier à mailles ¾ pour les pinces de plus de 23 cm de long:		Per pinze di lunghezza superiore a 23 cm si consiglia di usare un vassoio di grandezza ¾:
	Description	Quantité	Designazione
55-804-42-01	Panier à mailles, 410 x 255 x 53 mm	1	Vassoio reticolato, 410 x 255 x 53 mm
55-805-45-01	Couvercle, 410 x 255 mm	1	Coperchio, 410 x 255 mm
	Éléments de fixation		Elementi di fissaggio
55-806-02-04	Clip pour élément de fixation (UE = 10)	1	Clip per elemento di fissaggio (UV=10 pezzi)
55-806-07-04	Élément de fixation (UE = 6)	2	Elemento di fissaggio (UV=6 pezzi)

Bipolare Spülpinzetten, nonStick flush
Bipolar irrigation forceps, nonStick flush
Pinzas bipolares con función de enjuague, nonStick flush
Pincas d'irrigation bipolaires, nonStick flush
Pinze bipolari con irrigazione, nonStick flush

nonStick flush

Modellvielfalt

Alle gängigen Abmessungen für unterschiedliche Anwendungen

Variety of models

All common dimensions for different applications

Diversidad de modelos

Todas las dimensiones habituales para diferentes aplicaciones

De nombreux modèles

Toutes les dimensions courantes pour applications diverses

Molteplicità di modelli

Tutte le dimensioni di uso comune per le diverse applicazioni

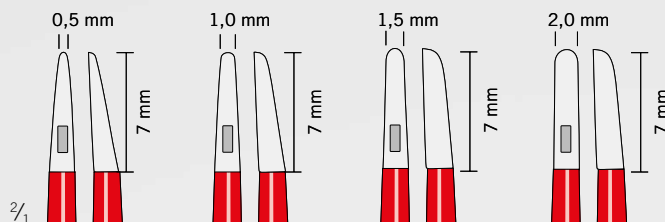

Pinzettenspitzen

- Die Spülöffnung befindet sich direkt auf der Fassfläche

The tips of the forceps

- The irrigation opening is located right on the gripping surfaces

Las puntas de la pinza

- La abertura se encuentra directamente en la superficie de sujeción

Pointes de la pince

- L'orifice d'irrigation se trouve directement sur la surface de saisie

Punte delle pinze

- L'orificio di irrigazione si trova direttamente sulla superficie di presa





- Integration des Spülkanals in den Schenkel
- Integration of the irrigation channel in the handle
- Integración del canal de irrigación en la rama
- Intégration du canal d'irrigation dans la branche
- Integrazione del canale di irrigazione nella branca

- Zufuhr der Spülflüssigkeit über Luer-Lock-Anschluss
- The irrigation fluid is supplied via the Luer Lock connection
- La alimentación del líquido se realiza a través de un conector Luer-Lock
- Le liquide d'irrigation est amené via le raccord Luer-Lock
- L'apporto del liquido di irrigazione avviene mediante il raccordo Luer-Lock



- Europäischer Flachpin-Stecker
- European flat-pin plug
- Clavija europea de pin plano
- Fiche européenne à broche plate
- Spina europea a pin piatto



- Präzise Führung der Pinzettenspitzen
- Precision guidance of forceps tips
- Guiado preciso de las puntas de las pinzas
- Les pointes de la pince sont guidées avec précision
- Meccanismo di guida precisa delle punte delle pinze

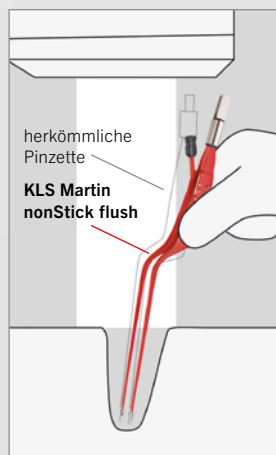

- Sichtoptimierte Schenkelgeometrie für die Anwendung unter dem OP-Mikroskop
- View-optimized shank geometry for applications under the operating microscope
- Geometría optimizada de las ramas en pro de la visibilidad para la aplicación bajo el microscopio quirúrgico
- Géométrie des branches optimisée pour une visibilité accrue sous le microscope opératoire
- Geometria delle branche a visibilità perfezionata per applicazione sotto il microscopio operatorio

max. 500 V_p



2/1

Beispielabbildung
 Example illustration
 Ilustración a modo de ejemplo
 Illustration à titre d'exemple
 Figura di esempio

Bipolare Pinzetten, bajonettförmig, mit *einseitiger* Spülung
 Bipolar forceps, bayonet-shaped with irrigation *on one side*
 Pinzas bipolares, bayoneta, con función de enjuague *unilateral*
 Pincas bipolaires, à baïonnette, avec irrigation *unilatérale*
 Pinze bipolari, a baionetta, con irrigazione *unilaterale*

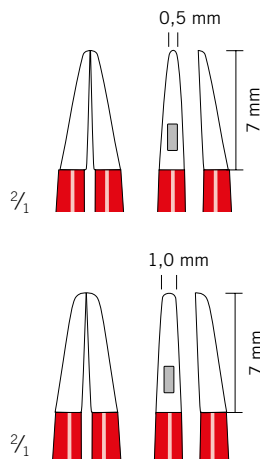

Spitzenbreite Tip width Ancho de la punta Largeur des pointes Larghezza delle punte	Länge Length Longitud Longueur Lunghezza	Artikel-Nr. Item No. N.º referencia Référence Codice articolo
---	--	---

stumpf/blunt/roma/mousse/smussa

0.5 x 7 mm	20 cm/8"	80-981-01-04
0.5 x 7 mm	23 cm/9"	80-981-03-04

stumpf/blunt/roma/mousse/smussa

1.0 x 7 mm	20 cm/8"	80-981-02-04
1.0 x 7 mm	23 cm/9"	80-981-04-04

2/1

Zubehör
 Accessories
 Accesorios
 Accessoires
 Accessori

80-981-07-04

Set Reinigungsbürsten, 5 Stück

Im Lieferumfang der Pinzetten sind bereits Reinigungsbürsten enthalten.

Cleaning brush set, 5 qty.

Cleaning brushes are included in delivery with the forceps.

Juego de cepillos de limpieza, 5 unidades

Las prestaciones del suministro de la pinza ya incluyen cepillos de limpieza.

Set de brosses de nettoyage, 5 pièces

Plusieurs brosses de nettoyage sont d'ores et déjà comprises dans l'étendue de livraison des pincas.

Set di spazzole di pulitura, 5 pezzi

Nella fornitura sono già comprese le spazzole di pulitura.



max. 500 V_p



Bipolare Pinzetten, gerade, mit einseitiger Spülung
Bipolar forceps, straight, with irrigation on one side
Pinzas bipolares, rectas, con función de enjuague unilateral
Pinces bipolaires, droites, avec irrigation unilatérale
Pinze bipolari, diritte, con irrigazione unilaterale

Spitzenbreite Tip width Ancho de la punta Largeur des pointes Larghezza delle punte	Länge Length Longitud Longueur Lunghezza	Artikel-Nr. Item No. N.º referencia Référence Codice articolo
1.5 x 7 mm	20 cm/8"	80-981-05-04

stumpf/blunt/roma/mousse/smussa

Bipolare Pinzetten, gerade, mit beidseitiger Spülung
Bipolar forceps, straight, with irrigation on both sides
Pinzas bipolares, rectas, con función de enjuague bilateral
Pinces bipolaires, droites, avec irrigation bilatérale
Pinze bipolari, diritte, con irrigazione bilaterale

Spitzenbreite Tip width Ancho de la punta Largeur des pointes Larghezza delle punte	Länge Length Longitud Longueur Lunghezza	Artikel-Nr. Item No. N.º referencia Référence Codice articolo
2.0 x 7 mm	23 cm/9"	80-981-06-04
2.0 x 7 mm	30 cm/11 3/4"	80-981-08-04

stumpf/blunt/roma/mousse/smussa



Anwendungsbeispiele:

- Viszeralchirurgie
- Leberchirurgie

Application examples:

- Visceral surgery
- Liver surgery

Ejemplos de aplicación:

- Cirugía visceral
- Cirugía hígado

Exemples d'applications:

- Chirurgie viscérale
- Chirurgie du foie

Esempi di applicazione:

- Chirurgia viscerale
- Chirurgia fegato

Beispielabbildung
 Example illustration
 Ilustración a modo de ejemplo
 Illustration à titre d'exemple
 Figura di esempio

Beispielabbildung
 Example illustration
 Ilustración a modo de ejemplo
 Illustration à titre d'exemple
 Figura di esempio

maXium® and nonStick flush

EHT – eine wirksame nonStick-Methode in der Elektrochirurgie

EHT – an effective nonStick method in electrosurgery

EHT – un método nonStick eficaz en electrocirugía

EHT – une méthode nonStick efficace en électrochirurgie

EHT – un efficace metodo nonStick in elettrochirurgia



Neptun



**Neptun
Auto-Start**

Die bipolare Stromart „**Neptun**“ des HF-Generators maXium® wurde speziell für die flüssigkeitsunterstützte HF-Koagulation entwickelt (**EHT = Elektrohydrothermosation**). Diese Methode hat sich speziell bei Anwendungen in der Viszeral- und Neurochirurgie bewährt. Die bipolare Koagulation erfolgt indirekt über die erhitzte isotonische Kochsalzlösung. Die Stromart ist an die Bedürfnisse der bipolaren Spülpinzetten nonStick flush angepasst.

Natürlich sind die nonStick-flush-Pinzetten auch mit den am Markt gängigen HF-Generatoren einsetzbar.

The "**Neptun**" current type of the maXium® HF generator was developed specifically for fluid-assisted HF coagulation (**EHT = electrohydrothermosation**). This method has been well proven, especially in abdominal and neurosurgery applications. Bipolar coagulation is carried out indirectly via the heated isotonic saline solution. The type of current is adapted to the requirements of the nonStick flush bipolar irrigation forceps.

The nonStick flush forceps can naturally also be used with currently available HF generators.

El tipo de corriente bipolar "**Neptun**" del generador de AF maXium® ha sido especialmente desarrollado para la coagulación de AF asistida por líquido (**EHT = electrohydrothermosation**). Este método se ha acreditado especialmente en aplicaciones de la cirugía visceral y la neurocirugía. La coagulación se realiza indirectamente a través del suero fisiológico isotónico caliente. Este tipo de corriente está adaptado a los requerimientos de la pinza bipolar con función de enjuague nonStick flush.

Naturalmente, las pinzas nonStick flush también pueden utilizarse con los generadores de AF habituales del mercado.











Le type de courant bipolaire «**Neptun**» du générateur HF maXium® a été spécialement conçu pour la coagulation HF assistée par liquide (**EHT = electrohydrothermosation**). Cette méthode a fait notamment ses preuves dans les applications en chirurgie viscérale et en neurochirurgie. La coagulation bipolaire s'effectue indirectement via la solution isotonique de chlorure de sodium chauffée. Ce type de courant est adapté aux exigences des pinces d'irrigation bipolaires nonStick flush.

Il va de soi que les pinces nonStick flush peuvent également être employées avec les générateurs HF que l'on trouve couramment sur le marché.

Il tipo di corrente bipolare "**Neptun**" del generatore AF maXium® è stato realizzato appositamente per la coagulazione AF liquido-assistita (EHT = electrohydrothermosation). Questo metodo ha dimostrato la propria efficacia soprattutto in applicazioni di chirurgia viscerale e neurologica. La coagulazione bipolare avviene indirettamente sulla soluzione fisiologica isotonica riscaldata. Questo tipo di corrente è adattato ai requisiti delle pinze bipolari con irrigazione nonStick flush.

Naturalmente le pinze nonStick flush possono essere utilizzate anche con i generatori AF comunemente in commercio.

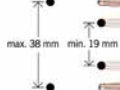

<p>Instrumente Instruments Instrumentos Instruments Strumenti</p> <p>Geräte Units Equipos Appareils Apparecchi</p>	<p>Europäischer Flachstecker, rund European flat plug, round Enchufe plano para Europa, redondo Fiche plate européenne, ronde Spina piatta europea, rotonda</p> <p>max. 600 V_p max. 850 V_p</p>  
<p>KLS Martin Berchtold Aesculap</p>  	<p>80-287-33-04 3 m/10 ft.</p> <p>80-287-53-04 5 m/16 ft.</p> <p>80-291-40-04 4 m/13 ft.</p>
<p>maXium® e Erbe ICC Erbe ACC Erbe VIO</p>  	<p>80-286-30-04 3 m/10 ft.</p> <p>80-286-50-04 5 m/16 ft.</p> <p>80-286-40-04 4 m/13 ft.</p>
<p>maXium® i maXium® e ME MB 2 i ME MB 3 i Valleylab</p>  	<p>80-287-89-04 3 m/10 ft.</p> <p>80-287-90-04 5 m/16 ft.</p> <p>80-293-40-04 4 m/13 ft.</p>
<p>Codman Valleylab</p>  	<p>80-287-72-04 5 m/16 ft.</p>



mit geradem Stecker
 with straight plug
 con clavija recta
 avec fiche droite
 con spina diritta



mit abgewinkeltem Stecker
 with angled plug
 con clavija acodada
 avec fiche coudée
 con spina piegata

Weitere Informationen entnehmen Sie bitte der separaten Broschüre sowie unseren Anwendungsberichten.

For further information please refer to our separate product brochure and our application reports.

Encontrará informaciones adicionales en el folleto individual y nuestros informes de aplicación.

Vous trouverez des informations supplémentaires dans la brochure et dans nos rapports d'application.

Per ulteriori informazioni vedasi il prospetto separato ed i nostri rapporti d'applicazione.

Übersicht der Wechselelektroden
Overview of exchangeable electrodes
Resumen de los electrodos intercambiables
Présentation des électrodes interchangeables
Presentazione degli elettrodi intercambiabili

Arbeitslänge 34 cm
Working length 34 cm
Longitud de trabajo 34 cm
Longueur d'utilisation 34 cm
Lunghezza dell'uso 34 cm

max. 500 V_p



83-585-03-04
marLap® Cut

Scheren-Wechselelektrode, gebogen, 340 mm,
zum mechanischen Schneiden bei gleichzeitiger Koagulation

Scissor-type exchangeable electrode, curved, 340 mm,
for mechanical cutting and simultaneous coagulation

Electrodo intercambiable tipo tijeras, 340 mm,
para el corte mecánico y coagulación simultánea

Électrode ciseaux interchangeable, 340 mm,
pour la coupe mécanique avec coagulation simultanée

Elettrodo intercambiabile tipo forbici, 340 mm,
per l'incisione meccanica in condizioni di coagulazione simultanea



83-585-05-04
marLap® Clamp

Fasszangen-Wechselelektrode, gefenestert, 340 mm,
zur Versiegelung von Gefäßen und Gewebebündeln

Grasping forceps exchangeable electrode, fenestrated, 340 mm,
for sealing vessels and tissue bundles

Electrodo intercambiable tipo pinza de secuestros, con ventana, 340 mm,
para el sellado vascular y de haces de tejido

Électrode pince interchangeable, fenêtrée, 340 mm,
pour le clamage des vaisseaux et des faisceaux de tissus

Elettrodo intercambiabile tipo clamp, con finestra, 340 mm,
per la coagulazione di vasi e di fasci di tessuto



83-585-06-04
marLap® Maryland

Fasszangen-Wechselelektrode, gebogen, 340 mm,
zum Präparieren und Koagulieren

"Grasping forceps" exchangeable electrode,
curved, 340 mm, for dissecting and coagulating

Electrodo intercambiable tipo pinza de secuestros, acodado,
340 mm, para diseccionar y coagular

Électrode pince interchangeable, courbe, 340 mm,
pour la dissection et la coagulation

Elettrodo intercambiabile tipo clamp, versione curva, 340 mm,
piegato, per le operazioni di preparazione e per
la coagulazione



83-585-07-04
marLap® Clamp

Fasszangen-Wechselelektrode, ungenestert, glatt, 340 mm,
zur Koagulation von Gefäßen und Gewebebündeln

Grasping forceps exchangeable electrode, non-fenestrated, smooth, 340 mm,
for coagulating vessels and tissue bundles

Electrodo intercambiable tipo pinza de secuestros, no fenestrado, 340 mm,
para el coagulación vascular y de haces de tejido

Électrode pince interchangeable, non fenêtrée, 340 mm,
pour le coagulation des vaisseaux et des faisceaux de tissus

Elettrodo intercambiabile tipo clamp, senza finestra,
liscio, 340 mm, per la coagulazione di vasi e
di fasci di tessuto





max. 500 V_p



83-585-01-04
 Handgriff
 Handle
 Mango
 Manche
 Manico

83-585-02-04
 Schaft
 Shaft
 Vástago
 Tige
 Asta

83-585-00-04 max. 500 V_p
 marLap® 340 mm, Ø 5 mm
 Handgriff mit Schaft
 Handle with shaft
 Mango con vástago
 Manche avec tige
 Manico con asta

4



Geräte Units Equipos Appareils Apparecchi	Instrumente Instruments Instrumentos Instruments Strumenti	Europäischer Flachstecker, rund European flat plug, round Enchufe plano para Europa, redondo Fiche plate européenne, ronde Spina piatta europea, rotonda	
		max. 600 V _p	max. 850 V _p
KLS Martin Berchtold Aesculap		80-287-33-04 3 m/10 ft. 80-287-53-04 5 m/16 ft.	80-291-40-04 4 m/13 ft.
maXium® e Erbe ICC Erbe ACC Erbe VIO		80-286-30-04 3 m/10 ft. 80-286-50-04 5 m/16 ft.	80-286-40-04 4 m/13 ft.
maXium® i maXium® e ME MB 2 i ME MB 3 i Valleylab		80-287-89-04 3 m/10 ft. 80-287-90-04 5 m/16 ft.	80-293-40-04 4 m/13 ft.
Codman Valleylab		80-287-72-04 5 m/16 ft.	

Bipolare Elektroden für die Arthroskopie
 Bipolar Electrodes for Arthroscopy
 Electrodo bipolar para la artroscopia
 Electrodes bipolaires pour arthroscopie
 Elettrodi bipolari per artroscopia



- ✓ Ergonomisch Ergonomic Ergonómicos Ergonomiques Ergonomici
- ✓ Kompakt Compact Compactos Compactes Compatti
- ✓ Sicher Safe Seguros Sûres Sicuri



80-650-00-04 **max. 1000 V_p**
 Bipolare Elektrode „Cobra“, Länge 115 mm
 “Cobra” bipolar electrode, length 115 mm
 Electrodo bipolar “Cobra”, longitud 115 mm
 Electrode bipolaire «Cobra», longueur 115 mm
 Elettrodo bipolare “Cobra”, lunghezza 115 mm



80-651-00-04 **max. 1000 V_p**
 Bipolare Hakenelektrode, Länge 115 mm, 0,6 mm
 Bipolar hook electrode, length 115 mm, 0.6 mm
 Electrodo bipolar de gancho, longitud 115 mm, 0,6 mm
 Electrode à crochet bipolaire, longueur 115 mm, 0,6 mm
 Elettrodo bipolare ad uncino, lunghezza 115 mm, 0,6 mm



80-652-00-04 **max. 1000 V_p**
 Bipolare Vaporisationselektrode „Phazer“, biegsam, inkl. Biegehilfe (80-652-01-04)
 “Phazer” bipolar vaporization electrode, flexible, incl. bending device (80-652-01-04)
 Electrodo de vaporización bipolar “Phazer”, flexible, incluye dispositivo de torsión (80-652-01-04)
 Electrode de vaporisation bipolaire «Phazer», flexible, avec dispositif de pliage (80-652-01-04)
 Elettrodo di vaporizzazione bipolare „Phazer“, flessibile, compreso dispositivo di curvatura (80-652-01-04)





Cobra

Electrode



4

maXium®



Weitere Informationen entnehmen Sie bitte der separaten Broschüre.
 For further information please refer to our separate product brochure.
 Encontrará informaciones adicionales en el folleto individual.
 Vous trouverez des informations supplémentaires dans la brochure.
 Per ulteriori informazioni vedasi il prospetto separato.



Schnittstelle Generator
 Interface generator
 Interfaz generador
 Interface générateur
 Interfaccia generatore

Schnittstelle Elektrode
 Interface electrode
 Interfaz electrodo
 Interface électrode
 Interfaccia elettrodo

1/3



80-288-70-04 **max. 700 V_p**
 3 m/10 ft.

Anschlusskabel für bipolare Elektroden, maXium® **m**
 Connecting cable for bipolar electrodes, maXium® **m**
 Cable de conexión para electrodos bipolares, maXium® **m**
 Câble de raccordement pour électrodes bipolaires, maXium® **m**
 Cavo di collegamento per elettrodi bipolari, maXium® **m**

Schnittstelle Generator
 Interface generator
 Interfaz generador
 Interface générateur
 Interfaccia generatore

Schnittstelle Elektrode
 Interface electrode
 Interfaz electrodo
 Interface électrode
 Interfaccia elettrodo

1/3

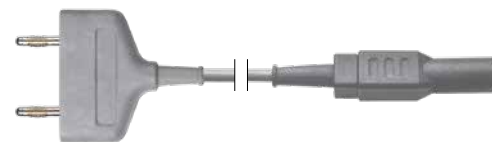

80-288-72-04 **max. 700 V_p**
 3 m/10 ft.

Anschlusskabel für bipolare Elektroden, maXium® **i**
 Connecting cable for bipolar electrodes, maXium® **i**
 Cable de conexión para electrodos bipolares, maXium® **i**
 Câble de raccordement pour électrodes bipolaires, maXium® **i**
 Cavo di collegamento per elettrodi bipolari, maXium® **i**

5

Instrumentarium zur bipolaren Gefäßversiegelung
Instruments for bipolar vessel sealing
Instrumentos para el sellado vascular bipolar
Instruments pour la clampage vasculaire bipolaire
Strumenti di sigillatura vascolare bipolare



Bipolare Klemmen für die Gefäßversiegelung
 Bipolar forceps for vessel sealing
 Pinzas bipolares para el sellado vascular
 Pincas bipolaires pour le clampage vasculaire
 Pinze bipolari per clampaggio vascolare

marClamp® IQ



✓ Präparieren	Dissect	Diseccionar	Disséquer	Sezionare
✓ Versiegeln	Seal	Sellar	Clamper	Sigillare
✓ Plug & Play	Plug & Play	Plug & Play	Plug & Play	Plug & Play
✓ Wiederverwendbar	Reusable	Reutilizable	Réutilisable	Riutilizzabile



marClamp®, gebogene Version
 marClamp®, curved version
 marClamp®, versión curva
 marClamp®, version courbe
 marClamp®, versione curva

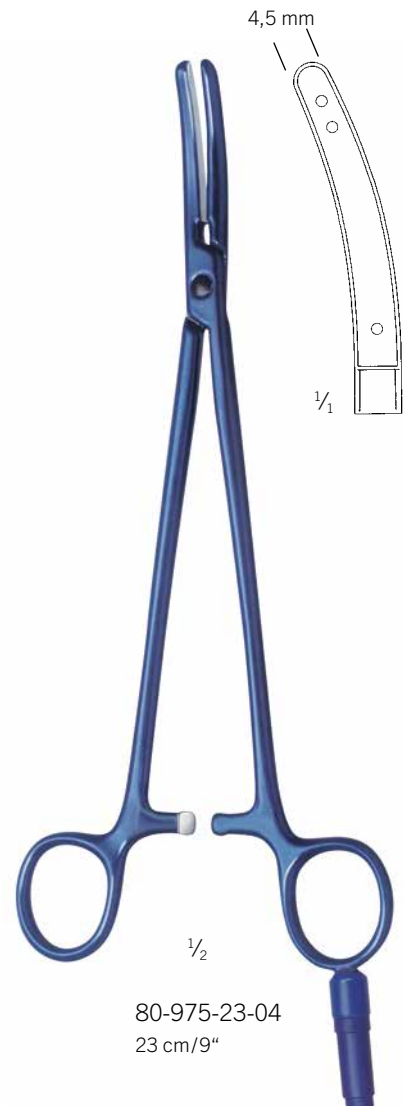
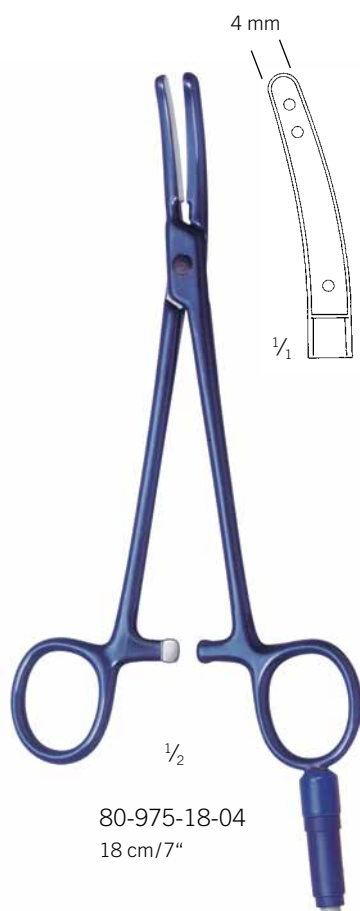

Bipolare Gefäßversiegelung
 Bipolar vessel sealing
 Sellado vascular bipolar
 Clampage vasculaire bipolaire
 Sigillatura vascolare bipolare



5

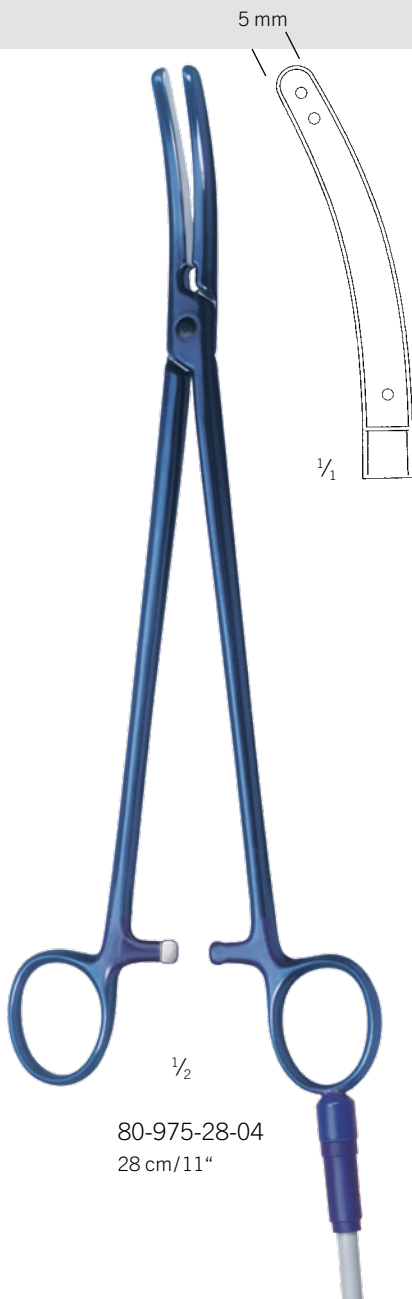

80-975-28-04
 28 cm/11"

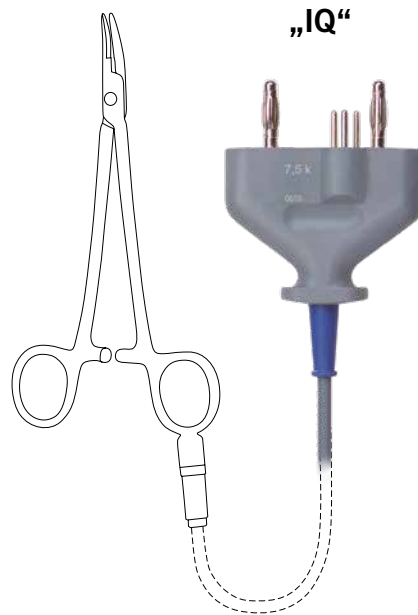

Weitere Informationen entnehmen Sie bitte der separaten Broschüre.
 For further information please refer to our separate product brochure.
 Encontrará informaciones adicionales en el folleto individual.
 Vous trouverez des informations supplémentaires dans la brochure.
 Per ulteriori informazioni vedasi il prospetto separato.

Bipolare Klemmen für die Gefäßversiegelung
 Bipolar forceps for vessel sealing
 Pinzas bipolares para el sellado vascular
 Pincès bipolaires pour le clamage vasculaire
 Pinze bipolari per clampaggio vascolare

marClamp® IQ



- | | | | | |
|--------------------------|------------------------|------------------------|------------------------|------------------------|
| ✓ Präparieren | Dissect | Diseccionar | Disséquer | Sezionare |
| ✓ Versiegeln | Seal | Sellar | Clamper | Sigillare |
| ✓ Plug & Play | Plug & Play | Plug & Play | Plug & Play | Plug & Play |
| ✓ Wiederverwendbar | Reusable | Reutilizable | Réutilisable | Riutilizzabile |

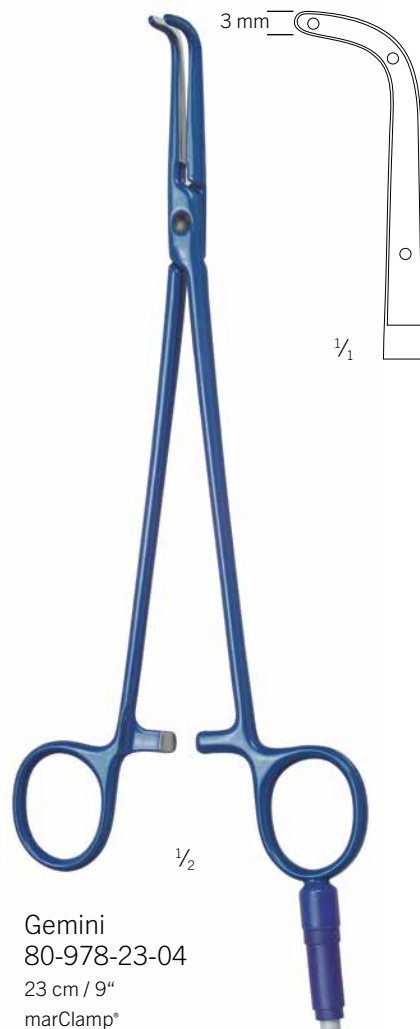

Bipolare Gefäßversiegelung
 Bipolar vessel sealing
 Sellado vascular bipolar
 Clampage vasculaire bipolaire
 Sigillatura vascolare bipolare

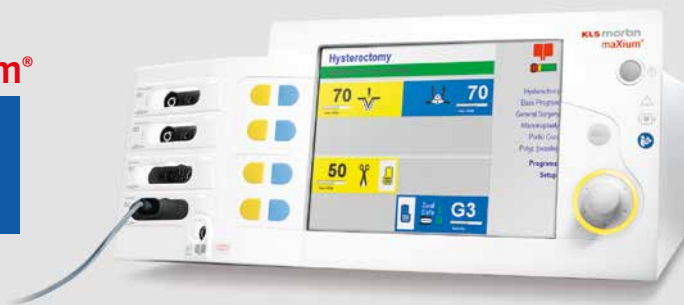

5

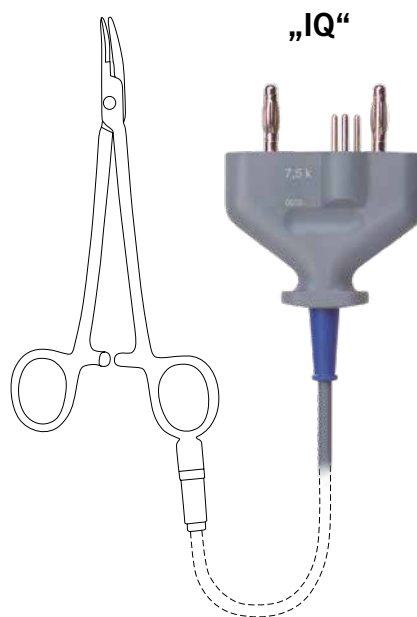

Weitere Informationen entnehmen Sie bitte der separaten Broschüre.
 For further information please refer to our separate product brochure.
 Encontrará informaciones adicionales en el folleto individual.
 Vous trouverez des informations supplémentaires dans la brochure.
 Per ulteriori informazioni vedasi il prospetto separato.

Kalem
 80-977-23-04
 24,5 cm / 9 5/8"
 marClamp® Uro

Kombi-Instrument für die offenchirurgische Gefäßversiegelung
 Combination instrument for open surgical vessel sealing
 Instrumento combinado para el sellado vascular en cirugía abierta
 Instrument combiné de scellement de vaisseaux sanguins pour la chirurgie ouverte
 Strumento combinato per la sigillatura vascolare nella chirurgia a cielo aperto

marClamp® Cut IQ



- | | | | | |
|--|---|--|--|---|
| ✓ Präparieren | Dissect | Diseccionar | Disséquer | Sezionare |
| ✓ Versiegeln | Seal | Sellar | Clamper | Sigillare |
| ✓ Trennen | Cut | Cortar | Couper | Separare |
| ✓ Plug & Play
(mit integriertem Schalter für maXium® Hardware 06, Software ab V 3.412) | Plug & Play
(with integrated switch for maXium® hardware 06, software from V 3.412) | Plug & Play
(con interruptor integrado para hardware maXium® 06, software a partir de V 3.412) | Plug & Play
(avec interrupteur intégré pour hardware maXium® 06, logiciel à partir de V 3.412) | Plug & Play
(con interruttore integrato per hardware maXium® 06, software a partire di V 3.412) |
| ✓ Kein Instrumentenwechsel | No need to exchange instruments | No es necesario cambiar de instrumento | Il n'est pas nécessaire de changer d'instruments | Senza necessità di cambiare strumento |
| ✓ Wiederverwendbar | Reusable | Reutilizable | Réutilisable | Riutilizzabile |

	marClamp®-Cut-IQ-System Instrument, komplett*, ohne Klingen	marClamp® Cut IQ System Instrument, complete*, without blades	Sistema marClamp® Cut IQ Instrumento, completo*, sin cuchillas
80-632-18-04	marClamp® Cut IQ, 18 cm	marClamp® Cut IQ, 18 cm	marClamp® Cut IQ, 18 cm

	Komponenten	Components	Componentes
80-632-00-04	Klinge für marClamp® Cut IQ, steril, VE=10	Blade for marClamp® Cut IQ, sterile, pack of 10	Cuchilla para marClamp® Cut IQ, estéril, UE=10
80-630-58-04	Reinigungswerkzeug	Cleaning tool	Herramienta de limpieza
80-632-01-04	Set Reinigungsbürsten, 3 Stück	Set of cleaning brushes, 3 pcs.	Juego de cepillos de limpieza, 3 unidades

* inkl. 80-630-58-04, 80-632-01-04

* incl. 80-630-58-04, 80-632-01-04

* incl. 80-630-58-04, 80-632-01-04

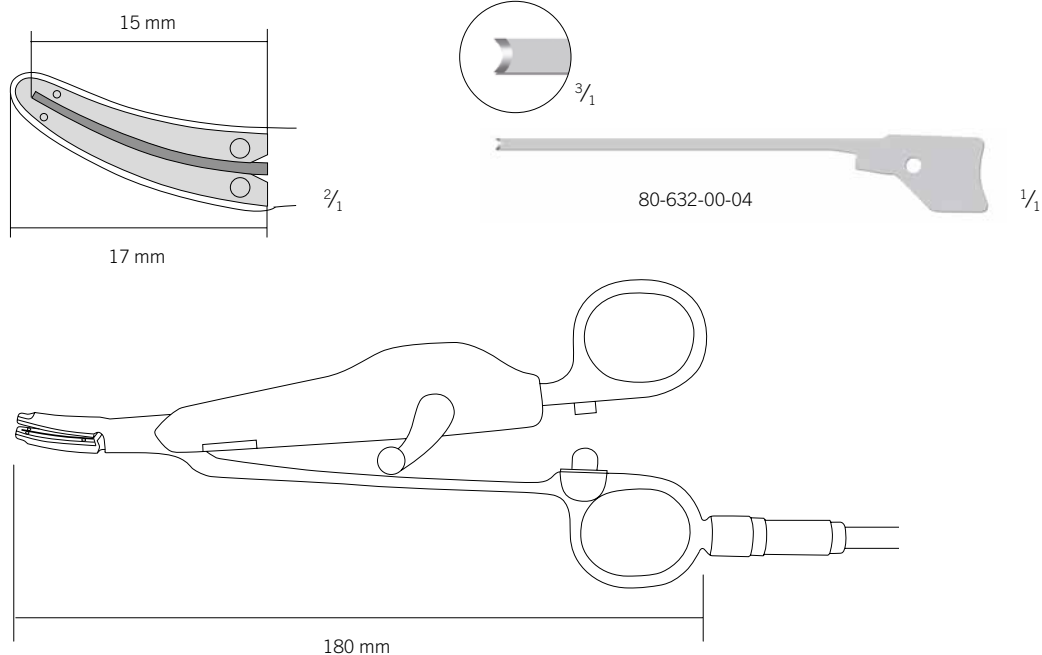

Bipolare Gefäßversiegelung
 Bipolar vessel sealing
 Sellado vascular bipolar
 Clampage vasculaire bipolaire
 Sigillatura vascolare bipolare



Integrierter Schalter zur Handaktivierung
 Integrated switch for manual activation
 Interruptor integrado para la activación manual
 Interrupteur intégré pour l'activation manuelle
 Interruttore integrato per l'attivazione manuale



5

	Système marClamp® Cut IQ Instrument, complet*, sans lames	Sistema marClamp® Cut IQ Strumento, completo*, senza lame
80-632-18-04	marClamp® Cut IQ, 18 cm	marClamp® Cut IQ, 18 cm

	Composants	Componenti
80-632-00-04	Lame pour instrument marClamp® Cut IQ, stérile, UC=10	Lama per marClamp® Cut IQ, sterile, confezione=10 unità
80-630-58-04	Outil de nettoyage	Strumento di pulizia
80-632-01-04	Jeu de brosses de nettoyage, 3 unités	Set di spazzolini di pulizia, 3 pezzi

* incl. 80-630-58-04, 80-632-01-04

* incl. 80-630-58-04, 80-632-01-04

„IQ“

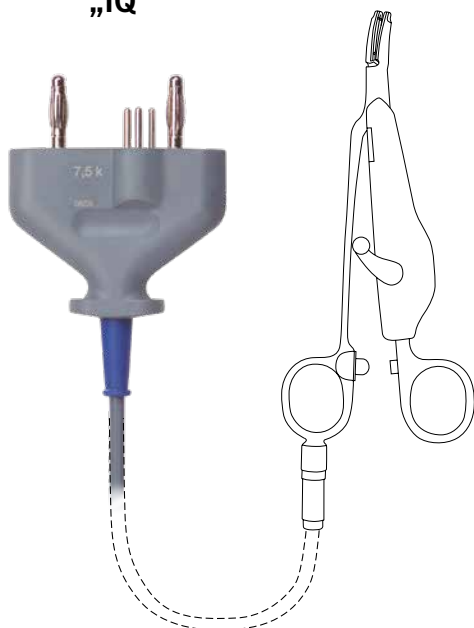

Weitere Informationen entnehmen Sie bitte der separaten Broschüre.

For further information please refer to our separate product brochure.

Encontrará informaciones adicionales en el folleto individual.

Vous trouverez des informations supplémentaires dans la brochure.

Per ulteriori informazioni vedasi il prospetto separato.

marSeal – bipolares Gefäßversiegelungssystem
 marSeal – bipolar vessel sealing system
 marSeal – sistema de sellado vascular bipolar
 marSeal – système bipolaire de clamage de vaisseaux
 marSeal – sistema bipolare di sigillatura dei vasi

marSeal IQ



- | | | | | |
|--|---|--|--|---|
| ✓ Präparieren | Dissect | Disseccionar | Disséquer | Sezionare |
| ✓ Versiegeln | Seal | Sellar | Clamper | Sigillare |
| ✓ Trennen | Cut | Cortar | Couper | Separare |
| ✓ Plug & Play
(mit Fingerschaltung nur bei IQ und für maXium® Hardware 06) | Plug & Play
(with finger switch operation only with IQ and for maXium® hardware 06) | Plug & Play
(con control a través de interruptor manual sólo con IQ y para el hardware 06 del maXium®) | Plug & Play
(avec commande manuelle uniquement sur IQ et pour version matérielle maXium® HW06) | Plug & Play
(con interruttore manuale solo per IQ e per maXium® con versione hardware 06) |
| ✓ Kein Instrumentenwechsel | No need to exchange instruments | No es necesario cambiar de instrumento | Il n'est pas nécessaire de changer d'instruments | Senza necessità di cambiare strumento |
| ✓ Wiederverwendbar | Reusable | Reutilizable | Réutilisable | Riutilizzabile |

	marSeal-System Instrument, komplett*, ohne Klängen	marSeal System Instrument, complete*, without blades	Sistema marSeal Instrumento, completo*, sin cuchillas
80-630-41-04	„IQ“-Version	“IQ” version	Versión “IQ”

	Komponenten	Components	Componentes
80-630-45-04	Handgriff „IQ“	Handle “IQ”	Mango “IQ”
80-630-12-04	Rohrschaft**	Tubular shaft**	Vástago de tubo**
80-630-15-04	Klinge zum Einmalgebrauch, VE = 6 Stck.	Disposable blade, SU = 6/pack	Hoja desechable, UV = 6 piezas
80-630-17-04	Reinigungswerkzeug	Cleaning tool	Herramienta de limpieza
80-630-18-04	Spüladapter	Flushing adapter	Adaptador de enjuague

* inkl. 80-630-17-04, 80-630-18-04
 ** inkl. 80-630-17-04

* incl. 80-630-17-04, 80-630-18-04
 ** incl. 80-630-17-04

* incl. 80-630-17-04, 80-630-18-04
 ** incl. 80-630-17-04

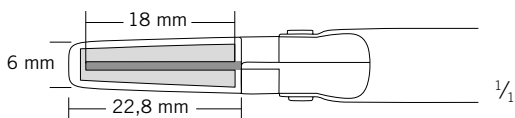

Bipolare Gefäßversiegelung
 Bipolar vessel sealing
 Sellado vascular bipolar
 Clampage vasculaire bipolaire
 Sigillatura vascolare bipolare



Über Fingerschaltung aktivierbar
 Can be activated via finger switch operation
 Puede activarse a través de interruptor manual
 Activable par commande manuelle
 Attivazione tramite l'interruttore manuale



5

	Système marSeal Instrument, complet*, sans lames	Sistema marSeal Strumento, completo*, senza lame
80-630-41-04	Version «IQ»	Versione «IQ»

	Composants	Componenti
80-630-45-04	Manche «IQ»	Impugnatura «IQ»
80-630-12-04	Tige tubulaire**	Guaina tubo**
80-630-15-04	Lame à usage unique, UC = 6 unités	Lama monouso, UV = 6 pezzi
80-630-17-04	Outil de nettoyage	Strumento di pulizia
80-630-18-04	Adaptateur de rinçage	Adattatore di lavaggio

* incl. 80-630-17-04, 80-630-18-04
 ** incl. 80-630-17-04

* incl. 80-630-17-04, 80-630-18-04
 ** incl. 80-630-17-04



4 m/13 ft.



Weitere Informationen entnehmen Sie bitte der separaten Broschüre.

For further information please refer to our separate product brochure.

Encontrará informaciones adicionales en el folleto individual.

Vous trouverez des informations supplémentaires dans la brochure.

Per ulteriori informazioni vedasi il prospetto separato.

marSeal slim – bipolares Gefäßversiegelungssystem
 marSeal slim – bipolar vessel sealing system
 marSeal slim – sistema de sellado vascular bipolar
 marSeal slim – système bipolaire de clamage de vaisseaux
 marSeal slim – sistema bipolare di sigillatura dei vasi

marSeal slim IQ



- | | | | | |
|--|---|--|--|---|
| ✓ Präparieren | Dissect | Disseccionar | Disséquer | Sezionare |
| ✓ Versiegeln | Seal | Sellar | Clamper | Sigillare |
| ✓ Trennen | Cut | Cortar | Couper | Separare |
| ✓ Plug & Play
(mit Fingerschaltung nur bei IQ und für maXium® Hardware 06) | Plug & Play
(with finger switch operation only with IQ and for maXium® hardware 06) | Plug & Play
(con control a través de interruptor manual sólo con IQ y para el hardware 06 del maXium®) | Plug & Play
(avec commande manuelle uniquement sur IQ et pour version matérielle maXium® HW06) | Plug & Play
(con interruttore manuale solo per IQ e per maXium® con versione hardware 06) |
| ✓ Kein Instrumentenwechsel | No need to exchange instruments | No es necesario cambiar de instrumento | Il n'est pas nécessaire de changer d'instruments | Senza necessità di cambiare strumento |
| ✓ Wiederverwendbar | Reusable | Reutilizable | Réutilisable | Riutilizzabile |

	marSeal-slim-System Instrument, komplett*, ohne Klängen	marSeal slim System Instrument, complete*, without blades	Sistema marSeal slim Instrumento, completo*, sin cuchillas
80-630-42-04	„IQ“-Version, Schaftlänge 370 mm	“IQ” version, shaft length 370 mm	Versión “IQ”, longitud de vástago 370 mm
80-630-43-04	„IQ“-Version, Schaftlänge 200 mm	“IQ” version, shaft length 200 mm	Versión “IQ”, longitud de vástago 200 mm

	Komponenten	Components	Componentes
80-630-45-04	Handgriff „IQ“	Handle “IQ”	Mango “IQ”
80-630-34-04	Rohrschaft, Länge 370 mm**	Tubular shaft, 370 mm long**	Vástago de tubo, longitud 370 mm**
80-630-35-04	Rohrschaft, Länge 200 mm**	Tubular shaft, 200 mm long**	Vástago de tubo, longitud 200 mm**
80-630-15-04	Klinge zum Einmalgebrauch, VE = 6 Stck.	Disposable blade, SU = 6/pack	Hoja desechable, UV = 6 piezas
80-630-17-04	Reinigungswerkzeug	Cleaning tool	Herramienta de limpieza
80-630-18-04	Spüladapter	Flushing adapter	Adaptador de enjuague

* inkl. 80-630-17-04, 80-630-18-04
 ** inkl. 80-630-17-04

* incl. 80-630-17-04, 80-630-18-04
 ** incl. 80-630-17-04

* incl. 80-630-17-04, 80-630-18-04
 ** incl. 80-630-17-04

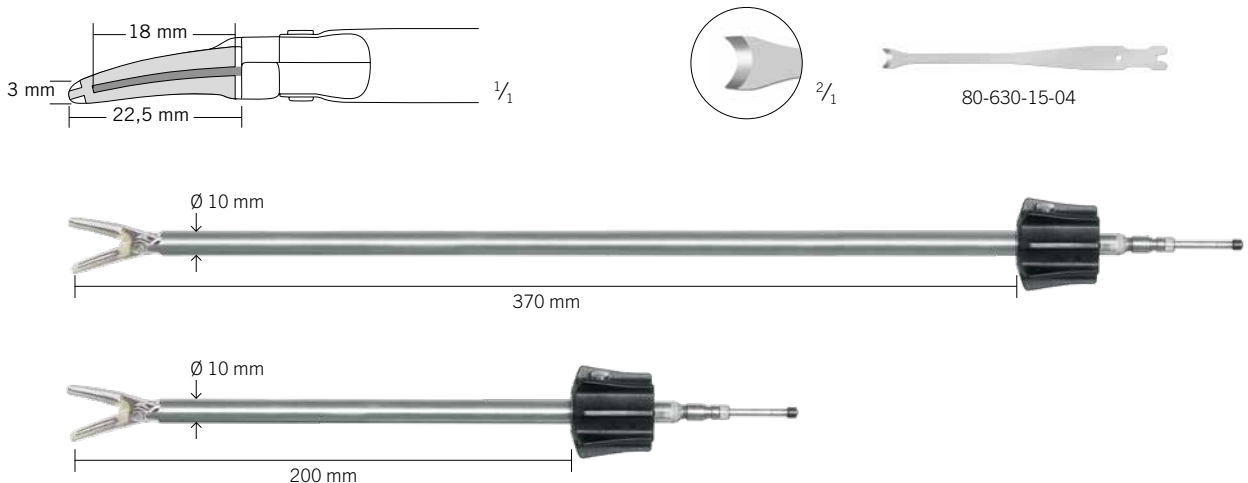

Bipolare Gefäßversiegelung
 Bipolar vessel sealing
 Sellado vascular bipolar
 Clampage vasculaire bipolaire
 Sigillatura vascolare bipolare



Über Fingerschaltung aktivierbar
 Can be activated via finger switch operation
 Puede activarse a través de interruptor manual
 Activable par commande manuelle
 Attivazione tramite l'interruttore manuale



5

	Système marSeal slim Instrument, complet*, sans lames	Sistema marSeal slim Strumento, completo*, senza lame
80-630-42-04	Version «IQ», longueur de tige 370 mm	Versione «IQ», lunghezza guaina 370 mm
80-630-43-04	Version «IQ», longueur de tige 200 mm	Versione «IQ», lunghezza guaina 200 mm

	Composants	Componenti
80-630-45-04	Manche «IQ»	Impugnatura «IQ»
80-630-34-04	Tige tubulaire, longueur 370 mm**	Lunghezza guaina tubo 370 mm**
80-630-35-04	Tige tubulaire, longueur 200 mm**	Lunghezza guaina tubo 200 mm**
80-630-15-04	Lame à usage unique, UC = 6 unités	Lama monouso, UV = 6 pezzi
80-630-17-04	Outil de nettoyage	Strumento di pulizia
80-630-18-04	Adaptateur de rinçage	Adattatore di lavaggio

* incl. 80-630-17-04, 80-630-18-04
 ** incl. 80-630-17-04

* incl. 80-630-17-04, 80-630-18-04
 ** incl. 80-630-17-04



4 m/13 ft.



Weitere Informationen entnehmen Sie bitte der separaten Broschüre.

For further information please refer to our separate product brochure.

Encontrará informaciones adicionales en el folleto individual.

Vous trouverez des informations supplémentaires dans la brochure.

Per ulteriori informazioni vedasi il prospetto separato.

marSeal5 – bipolares Gefäßversiegelungssystem
 marSeal5 – bipolar vessel sealing system
 marSeal5 – sistema de sellado vascular bipolar
 marSeal5 – système bipolaire de clamage de vaisseaux
 marSeal5 – sistema bipolare di sigillatura dei vasi

marSeal5 IQ



- | | | | | |
|--|---|--|--|---|
| ✓ Präparieren | Dissect | Disseccionar | Disséquer | Sezionare |
| ✓ Versiegeln | Seal | Sellar | Clamper | Sigillare |
| ✓ Trennen | Cut | Cortar | Couper | Separare |
| ✓ Plug & Play
(mit Fingerschaltung nur bei IQ und für maXium® Hardware 06) | Plug & Play
(with finger switch operation only with IQ and for maXium® hardware 06) | Plug & Play
(con control a través de interruptor manual sólo con IQ y para el hardware 06 del maXium®) | Plug & Play
(avec commande manuelle uniquement sur IQ et pour version matérielle maXium® HW06) | Plug & Play
(con interruttore manuale solo per IQ e per maXium® con versione hardware 06) |
| ✓ Kein Instrumentenwechsel | No need to exchange instruments | No es necesario cambiar de instrumento | Il n'est pas nécessaire de changer d'instruments | Senza necessità di cambiare strumento |
| ✓ Wiederverwendbar | Reusable | Reutilizable | Réutilisable | Riutilizzabile |

	marSeal5-System Instrument, komplett*, ohne Klinsen	marSeal5 System Instrument, complete*, without blades	Sistema marSeal5 Instrumento, completo*, sin cuchillas
80-630-50-04	„IQ“-Version, Schaftlänge 370 mm	“IQ” version, shaft length 370 mm	Versión “IQ”, longitud de vástago 370 mm
80-630-90-04	„IQ“-Version short, Schaftlänge 200 mm	“IQ” version, short, shaft length 200 mm	Versión “IQ” short, longitud de vástago 200 mm

	Komponenten	Components	Componentes
80-630-52-04	Handgriff „IQ“	Handle “IQ”	Mango “IQ”
80-630-51-04	Rohrschaft, Länge 370 mm**	Tubular shaft, 370 mm long**	Vástago tubular, longitud 370 mm**
80-630-92-04	Rohrschaft, Länge 200 mm**	Tubular shaft, 200 mm long**	Vástago tubular, longitud 200 mm**
80-630-53-04	Klingenträger, Länge 370 mm, zum Einmalgebrauch, VE = 6 Stck.	Disposable blade rod, 370 mm long, SU = 6/pack	Soporte desechable, longitud 370 mm, UE = 6 unidades
80-630-91-04	Klingenträger, Länge 200 mm, zum Einmalgebrauch, VE = 6 Stck.	Disposable blade rod, 200 mm long, SU = 6/pack	Soporte desechable, longitud 200 mm, UE = 6 unidades
80-630-83-04	Klingenträger, Länge 370 mm, zum Einmalgebrauch, steril, VE = 10 Stck.	Disposable blade rod, 370 mm long, sterile, SU = 10/pack	Soporte desechable, longitud 370 mm, estéril, UE = 10 unidades
80-630-58-04	Reinigungswerkzeug	Cleaning tool	Herramienta de limpieza
80-630-59-04	Spüladapter	Flushing adapter	Adaptador de enjuague

* inkl. 80-630-58-04, 80-630-59-04
 ** inkl. 80-630-58-04

* incl. 80-630-58-04, 80-630-59-04
 ** incl. 80-630-58-04

* incl. 80-630-58-04, 80-630-59-04
 ** incl. 80-630-58-04

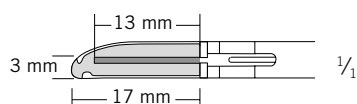

marSeal5 IQ

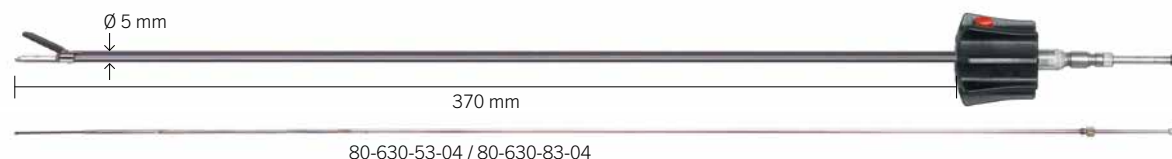

marSeal5 IQ short

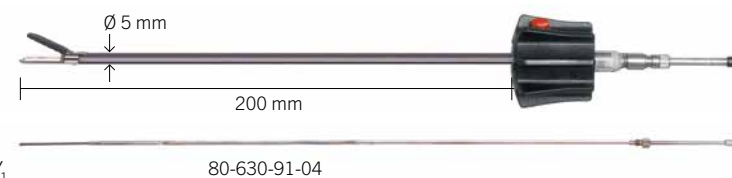

Bipolare Gefäßversiegelung
 Bipolar vessel sealing
 Sellado vascular bipolar
 Clampage vasculaire bipolaire
 Sigillatura vascolare bipolare



Über Fingerschaltung aktivierbar
 Can be activated via finger switch operation
 Puede activarse a través de interruptor manual
 Activable par commande manuelle
 Attivazione tramite l'interruttore manuale



5

	Système marSeal5 Instrument, complet*, sans lames	Sistema marSeal5 Strumento, completo*, senza lame
80-630-50-04	Version «IQ», longueur de tige 370 mm	Versione «IQ», lunghezza guaina 370 mm
80-630-90-04	Version «IQ» short, longueur de tige 200 mm	Versione «IQ» short, lunghezza guaina 200 mm

	Composants	Componenti
80-630-52-04	Poignée «IQ»	Impugnatura «IQ»
80-630-51-04	Tige tubulaire marSeal5, longueur 370 mm**	Lunghezza guaina tubo 370 mm**
80-630-92-04	Tige tubulaire marSeal5, longueur 200 mm**	Lunghezza guaina tubo 200 mm**
80-630-53-04	Porte-lame à usage unique, longueur 370 mm, UE = 6 pièces	Portalama monouso, lunghezza 370 mm, UV = 6 pezzi
80-630-91-04	Porte-lame à usage unique, longueur 200 mm, UE = 6 pièces	Portalama monouso, lunghezza 200 mm, UV = 6 pezzi
80-630-83-04	Porte-lame à usage unique, longueur 370 mm, stérile , UE = 10 pièces	Portalama monouso, lunghezza 370 mm, sterilmente , UV = 10 pezzi
80-630-58-04	Outil de nettoyage	Strumento di pulizia
80-630-59-04	Adaptateur de rinçage	Adattatore di lavaggio

* incl. 80-630-58-04, 80-630-59-04
 ** incl. 80-630-58-04

* incl. 80-630-58-04, 80-630-59-04
 ** incl. 80-630-58-04



4 m/13 ft.



Weitere Informationen entnehmen Sie bitte der separaten Broschüre.

For further information please refer to our separate product brochure.

Encontrará informaciones adicionales en el folleto individual.

Vous trouverez des informations supplémentaires dans la brochure.

Per ulteriori informazioni vedasi il prospetto separato.

marSeal5 plus – bipolares Gefäßversiegelungssystem
 marSeal5 plus – bipolar vessel sealing system
 marSeal5 plus – sistema de sellado vascular bipolar
 marSeal5 plus – système bipolaire de clampage de vaisseaux
 marSeal5 plus – sistema bipolare di sigillatura dei vasi

marSeal5 plus



Vessel Sealing in a new Dimension!



✓ Präparieren	Dissect	Disseccionar	Disséquer	Sezionare
✓ Versiegeln	Seal	Sellar	Clamper	Sigillare
✓ Trennen	Cut	Cortar	Couper	Separare
✓ Plug & Play (mit Fingerschaltung nur bei IQ und für maXium® Hardware 06, Software ab V 3.423)	Plug & Play (with finger switch operation only with IQ and for maXium® hardware 06, software from V 3.423)	Plug & Play (con control a través de interruptor manual sólo con IQ y para el hardware 06 del maXium®, software a partir de V 3.423)	Plug & Play (avec commande manuelle uniquement sur IQ et pour version matérielle maXium® HW06, logiciel à partir de V 3.423)	Plug & Play (con interruttore manuale solo per IQ e per maXium® con versione hardware 06, software a partire di V 3.423)
✓ Kein Instrumentenwechsel	No need to exchange instruments	No es necesario cambiar de instrumento	Il n'est pas nécessaire de changer d'instruments	Senza necessità di cambiare strumento
✓ Wiederverwendbar	Reusable	Reutilizable	Réutilisable	Riutilizzabile

	marSeal5-plus-System Instrument, komplett*, ohne Klängen	marSeal5 plus System Instrument, complete*, without blades	Sistema marSeal5 plus Instrumento, completo*, sin cuchillas
80-633-00-04	marSeal5 plus IQ Schaftlänge 370 mm	marSeal5 plus IQ shaft length 370 mm	marSeal5 plus IQ longitud del vástago 370 mm

	Einzelkomponenten	Individual components	Componentes individuales
80-633-04-04	Handgriff	Handle	Mango
80-633-05-04	Rohrschaft, Ø 5 mm, Schaftlänge 370 mm, bestehend aus Außen- und Innenrohr**	Tubular shaft, Ø 5 mm, shaft length 370 mm, consisting of outer and inner tube**	Vástago tubular, Ø 5 mm, longitud del vástago 370 mm, compuesto por tubo externo e interno**

	Verbrauchsmaterial	Consumables	Consumibles
80-633-09-04	Klingenträger, 370 mm, steril, VE=10 Stück	Blade holder, 370 mm, sterile, PU=10 pieces	Portacuchillas, 370 mm, ésteril, UE=10 unidades
80-633-11-04	Klingenträger, 370 mm, unsteril, VE=10 Stück	Blade holder, 370 mm, non-sterile, PU=10 pieces	Portacuchillas, 370 mm, no ésteril, UE=10 unidades

	Reinigungs- und Aufbereitungs-Tools	Cleaning and reprocessing tools	Herramientas de limpieza y acondicionamiento
80-633-12-04	Reinigungswerkzeug	Cleaning tool	Herramienta de limpieza
80-633-13-04	Spüladapter für Außen- und Innenrohr	Rinsing adapter for outer and inner tube	Adaptador de lavado por tubo externo e interno

* inkl. 80-633-12-04, 80-633-13-04
 ** inkl. 80-633-12-04

* incl. 80-633-12-04, 80-633-13-04
 ** incl. 80-633-12-04

* incl. 80-633-12-04, 80-633-13-04
 ** incl. 80-633-12-04

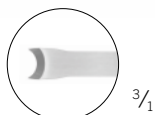
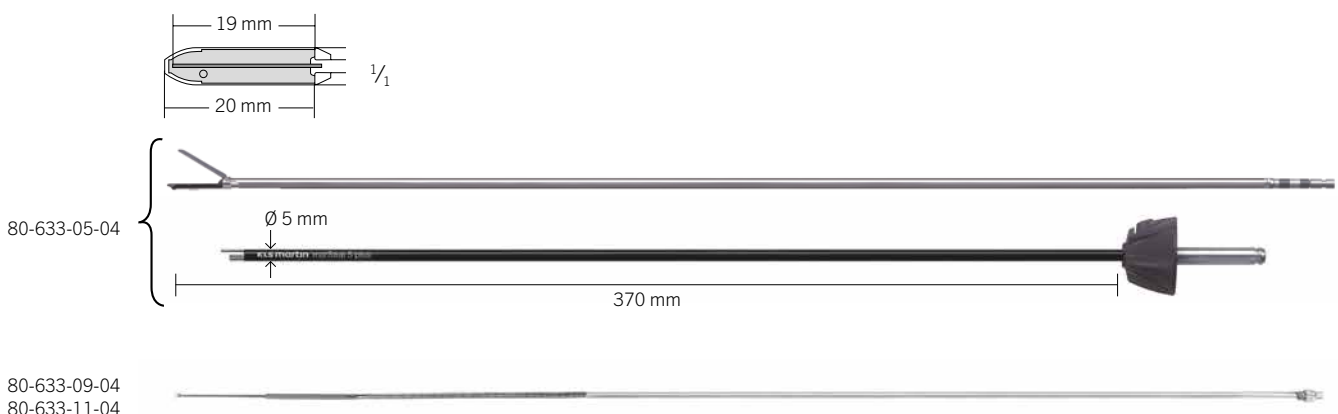

Bipolare Gefäßversiegelung
 Bipolar vessel sealing
 Sellado vascular bipolar
 Clampage vasculaire bipolaire
 Sigillatura vascolare bipolare

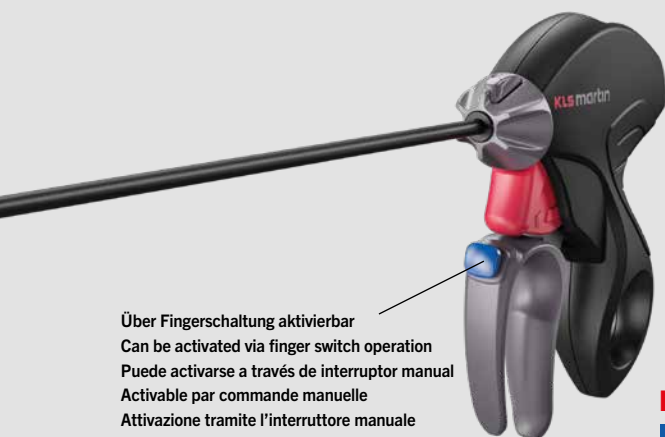

Über Fingerschaltung aktivierbar
 Can be activated via finger switch operation
 Puede activarse a través de interruptor manual
 Activable par commande manuelle
 Attivazione tramite l'interruttore manuale



5

	Système marSeal5 plus Instrument, complet*, sans lames	Sistema marSeal5 plus Strumento, completo*, senza lame
80-633-00-04	marSeal5 plus IQ longueur 370 mm	marSeal5 plus IQ lunghezza 370 mm
	Composants individuels	Componenti singoli
80-633-04-04	Poignée	Impugnatura
80-633-05-04	Tige tubulaire, Ø 5 mm, longueur 370 mm, composée d'un tube externe et interne**	Stelo tubulare, Ø 5 mm, lunghezza 370 mm, composto da tubo esterno ed interno**
	Consommables	Materiale di consumo
80-633-09-04	Porte-lame, 370 mm, stérile , UV=10 pièces	Portalama, 370 mm, sterile , UV=10 pezzi
80-633-11-04	Porte-lame, 370 mm, non-stérile, UV=10 pièces	Portalama, 370 mm, non sterile, UV=10 pezzi
	Outils de nettoyage et de préparation	Strumenti di pulizia e condizionamento
80-633-12-04	Outil de nettoyage	Utensile di pulizia
80-633-13-04	Adaptateur de rinçage pour tige tubulaire externe et interne	Adattatore di lavaggio per tubo esterno ed interno

* incl. 80-633-12-04, 80-633-13-04

** incl. 80-633-12-04

* incl. 80-633-12-04, 80-633-13-04

** incl. 80-633-12-04



4 m/13 ft.



Weitere Informationen entnehmen Sie bitte der separaten Broschüre.

For further information please refer to our separate product brochure.

Encontrará informaciones adicionales en el folleto individual.

Vous trouverez des informations supplémentaires dans la brochure.

Per ulteriori informazioni vedasi il prospetto separato.

Lagerung zur Reinigung und Sterilisation der Versiegelungsinstrumente
Storage for cleaning and sterilization of sealing instruments
Almacenamiento para la limpieza y esterilización de los instrumentos de sellado
Conservation en vue du nettoyage et de la stérilisation des instruments de coagulation
Posizionamento per la pulizia e la sterilizzazione degli strumenti di sigillatura

Für die Reinigung und Sterilisation kann zusätzlich das entsprechende Tray verwendet werden. Dieses Tray kann optional bestellt werden.

The corresponding tray can also be used for cleaning and sterilization. This tray can be ordered as an optional extra.

Para la limpieza y esterilización se puede utilizar adicionalmente la bandeja correspondiente. Esta bandeja se puede encargar opcionalmente.

Il est possible en supplément d'utiliser le plateau correspondant pour le nettoyage et la stérilisation. Ce plateau peut être commandé de manière facultative.

Per la pulizia e la sterilizzazione è possibile utilizzare anche il corrispondente vassoio. Il vassoio è ordinabile a richiesta.



55-803-71-04

530 x 250 x 60 mm

Lagerungstray marSeal5 plus mit Deckel

Storing tray marSeal5 plus with lid

Tray para depositar marSeal5 plus con tapa

Plateau pour déposer instruments marSeal5 plus avec couvercle

Bacinella per mettere strumenti marSeal5 plus con coperchio



55-803-73-04

530 x 250 x 60 mm

Lagerungstray marSeal5 IQ mit Deckel

Storing tray marSeal5 IQ with lid

Tray para depositar marSeal5 IQ con tapa

Plateau pour déposer instruments marSeal5 IQ avec couvercle

Bacinella per mettere strumenti marSeal5 IQ con coperchio

Die Instrumente sind nicht im Lieferumfang enthalten und müssen separat bestellt werden.

The instruments are not included in the scope of supply and therefore must be ordered separately.

Los instrumentos no forman parte de las prestaciones del suministro, debiéndolos encargar por separado.

Les instruments ne sont pas comprises dans la livraison et doivent être commandés séparément.

I strumenti non sono compresi nella fornitura e devono essere ordinati separatamente.



5

55-803-74-04

530 x 250 x 60 mm

Lagerungstray marSeal/marSeal slim IQ mit Deckel
Storing tray marSeal/marSeal slim IQ with lid
Tray para depositar marSeal/marSeal slim IQ con tapa
Plateau pour déposer marSeal/marSeal slim IQ avec couvercle
Bacinella per mettere marSeal/marSeal slim IQ con coperchio



55-803-75-04

280 x 170 x 40 mm

Lagerungstray marClamp® Cut IQ mit Deckel
Storing tray marClamp® Cut IQ with lid
Tray para depositar marClamp® Cut IQ con tapa
Plateau pour déposer instruments marClamp® Cut IQ avec couvercle
Bacinella per mettere strumenti marClamp® Cut IQ con coperchio

Die Instrumente sind nicht im Lieferumfang enthalten und müssen separat bestellt werden.
The instruments are not included in the scope of supply and therefore must be ordered separately.
Los instrumentos no forman parte de las prestaciones del suministro, debiéndolos encargar por separado.
Les instruments ne sont pas comprises dans la livraison et doivent être commandés séparément.
I strumenti non sono compresi nella fornitura e devono essere ordinati separatamente.

Anschlusskabel und Adapter
Connection cables and adapter
Cables de conexión y adaptadores
Câbles de raccordement et adaptateurs
Cavi di connessione e adattatori

6



max. 4000 V_p



80-289-40-04
 4 m/13 ft.
 KLS-Martin-Geräte
 → Instrumente mit 3-mm-Stecker (Olympus)
 KLS Martin units
 → instruments with 3-mm plug (Olympus)
 equipos de KLS Martin
 → instrumentos con clavija de 3 mm (Olympus)
 appareils KLS Martin
 → instruments avec fiche de 3 mm (Olympus)
 apparecchi di KLS Martin
 → strumenti con spina da 3 mm (Olympus)



83-120-50-04
 5 m/16 ft.
 KLS-Martin-Geräte
 → Instrumente mit 4-mm-Stecker
 KLS Martin units
 → instruments with 4-mm plug
 equipos de KLS Martin
 → instrumentos con clavija de 4 mm
 appareils KLS Martin
 → instruments avec fiche de 4 mm
 apparecchi di KLS Martin
 → strumenti con spina da 4 mm



80-285-40-04 80-285-50-04
 4 m/13 ft. 5 m/16 ft.
 KLS-Martin-Geräte
 → für Isolit-Pinzetten
 KLS Martin units
 → for Isolit forceps
 aparatos KLS Martin
 → para pinzas Isolit
 appareils KLS Martin
 → pour des pincés Isolit
 apparecchi KLS Martin
 → per pinze Isolit



80-289-42-04
 4 m/13 ft.
 maXium®e und Erbe-, ICC-, ACC- und VIO-Geräte
 → Instrumente mit 3-mm-Anschluss (Olympus)
 maXium®e and Erbe, ICC, ACC and VIO units
 → Instruments with 3-mm socket (Olympus)
 maXium®e y Erbe, ICC, ACC y VIO
 → Instrumentos con conexión de Ø 3 mm (Olympus)
 maXium®e et Erbe, ICC, ACC et VIO
 → Instruments avec prise de Ø 3 mm (Olympus)
 maXium®e e Erbe, ICC, ACC e VIO
 → Strumenti con presa da Ø 3 mm (Olympus)



83-122-60-04
 6 m/20 ft.
 maXium®e und Erbe-, ICC-, ACC- und VIO-Geräte
 → Instrumente mit 4-mm-Anschluss
 maXium®e and Erbe, ICC, ACC and VIO units
 → Instruments with 4-mm socket
 maXium®e y Erbe, ICC, ACC y VIO
 → Instrumentos con conexión de Ø 4 mm
 maXium®e et Erbe, ICC, ACC et VIO
 → Instruments avec prise de Ø 4 mm
 maXium®e e Erbe, ICC, ACC e VIO
 → Strumenti con presa da Ø 4 mm



83-122-50-04
 5 m/16 ft.
 Erbotom-Geräte
 → Instrumente mit 4-mm-Anschluss
 Erbotom electrosurgery units
 → Instruments with 4-mm socket
 aparatos Erbotom
 → instrumentos con conexión de Ø 4 mm
 appareils Erbotom
 → instruments avec prise de Ø 4 mm
 apparecchi Erbotom
 → strumenti con presa da Ø 4 mm



max. 4000 V_p



80-285-55-04
 4 m/13 ft.
 mit 3-Pin-Stecker
 → für Isolit-Pinzetten
 with 3-pin plug
 → for Isolit forceps
 con clavija de 3 patillas
 → para pinzas Isolit
 avec fiche à 3-broches
 → pour des pinces Isolit
 con spina a 3-spire
 → per pinze Isolit



80-289-41-04
 4 m/13 ft.
 mit 3-Pin-Stecker → Instrumente mit 3-mm-Stecker (Olympus)
 with 3-pin plug → Instruments with 3-mm plug (Olympus)
 con clavija de 3 patillas → Instrumentos con clavija de Ø 3 mm (Olympus)
 avec fiche à 3-broches → Instruments avec fiche de Ø 3 mm (Olympus)
 con spina a 3-spire → Strumenti con spina da Ø 3 mm (Olympus)



80-290-40-04
 4 m/13 ft.
 KLS-Martin-Geräte
 → Instrumente mit 3,2-mm-Stecker
 KLS Martin units
 → Instruments with 3.2-mm plug
 aparatos KLS Martin
 → Instrumentos con clavija de Ø 3,2 mm
 appareils KLS Martin
 → Instruments avec fiche de Ø 3,2 mm
 apparecchi KLS Martin
 → Strumenti con spina da Ø 3,2 mm



83-120-51-04
 5 m/16 ft.
 3-Pin-Stecker
 → Instrumente mit 4-mm-Stecker
 3-pin plug
 → Instruments with 4-mm plug
 clavija de 3 patillas
 → Instrumentos con clavija de Ø 4 mm
 fiche à 3-broches
 → Instruments avec fiche de Ø 4 mm
 spina a 3-spire
 → Strumenti con spina da Ø 4 mm

6



83-124-50-04
 5 m/16 ft.
 maXium®i, ME MB 3 i, ME MB 2 i und Valleylab-Geräte
 → MIC-Instrumente mit 4-mm-Anschluss
 maXium®i, ME MB 3 i, ME MB 2 i and Valleylab units
 → MIS Instruments with 4-mm socket
 maXium®i, ME MB 3 i, ME MB 2 i y aparatos Valleylab
 → Instrumentos para la cirugía mínima invasiva con conexión de Ø 4 mm
 maXium®i, ME MB 3 i, ME MB 2 i et appareils Valleylab
 → Instruments pour la chirurgie non-invasive avec prise de Ø 4 mm
 maXium®i, ME MB 3 i, ME MB 2 i e apparecchi Valleylab
 → Strumenti per la chirurgia mininvasiva con presa da Ø 4 mm



83-124-52-04
 4 m/13 ft.
 maXium®i, ME MB 3 i, ME MB 2 i und Valleylab-Geräte
 → für Isolit-Pinzetten
 maXium®i, ME MB 3 i, ME MB 2 i and Valleylab units
 → for Isolit forceps
 maXium®i, ME MB 3 i, ME MB 2 i y aparatos Valleylab
 → para pinzas Isolit
 maXium®i, ME MB 3 i, ME MB 2 i et appareils Valleylab
 → pour des pinces Isolit
 maXium®i, ME MB 3 i, ME MB 2 i e apparecchi Valleylab
 → per pinze Isolit

NON-CE



80-280-30-04
 3 m/10 ft.
 Anschlusskabel, einpolig,
 für Griff 80-213-01-04
 Connection cable, monopolar,
 for handle 80-213-01-04
 Cable de conexión, monopolar,
 para mango 80-213-01-04
 Câble de raccordement, monopolaire,
 pour manche 80-213-01-04
 Cavo di connessione, monopolare,
 per manico 80-213-01-04

max. 4000 V_p



80-286-94-04
 4 m/13 ft.
 3-Pin-Stecker
 → Olympus-Resektoskope
 3-pin plug
 → Olympus resectoscopes
 clavija de 3 patillas
 → resectoscopios Olympus
 fiche à 3-broches
 → résectoscopes Olympus
 con spina a 3-spire
 → resettoscopi Olympus



80-286-95-04
 4 m/13 ft.
 3-Pin-Stecker
 → Richard-Wolf-Resektoskope
 3-pin plug
 → Richard Wolf resectoscopes
 clavija de 3 patillas
 → resectoscopios Richard Wolf
 fiche à 3-broches
 → résectoscopes Richard Wolf
 spina a 3-spire
 → resettoscopi Richard Wolf



80-286-96-04
 4 m/13 ft.
 3-Pin-Stecker
 → Karl-Storz-Resektoskope
 3-pin plug
 → Karl Storz resectoscopes
 clavija de 3 patillas
 → resectoscopios Karl Storz
 fiche à 3-broches
 → résectoscopes Karl Storz
 spina a 3-spire
 → resettoscopi Karl Storz



80-287-33-04 80-287-53-04 **max. 600 V_p**
 3 m/10 ft. 5 m/16 ft.

KLS-Martin-, Berchtold- und Aesculap-Geräte
 → bipolare Instrumente

KLS Martin, Berchtold and Aesculap units
 → bipolar instruments

Aparatos KLS Martin, Berchtold y Aesculap
 → instrumentos bipolares

Câble de raccordement pour instruments bipolaires
 → instruments bipolaires

Apparecchi KLS Martin, Berchtold e Aesculap
 → strumenti bipolari



80-287-60-04 **max. 600 V_p**
 4 m/13 ft.

KLS-Martin-, Berchtold- und Aesculap-Geräte
 → bipolare Instrumente

KLS Martin, Berchtold and Aesculap units
 → bipolar instruments

Aparatos KLS Martin, Berchtold y Aesculap
 → instrumentos bipolares

Câble de raccordement pour instruments bipolaires
 → instruments bipolaires

Apparecchi KLS Martin, Berchtold e Aesculap
 → strumenti bipolari



80-287-42-04 **max. 600 V_p**
 3 m/10 ft.

KLS-Martin-Geräte
 → Storz bipolare Instrumente

KLS Martin units
 → Storz bipolar instruments

KLS Martin
 → Instrumentos bipolares Storz

appareils KLS Martin
 → Instruments bipolaires Storz

apparecchi KLS Martin
 → Strumenti bipolari Storz

6



80-285-51-04 **max. 500 V_p**
 4 m/13 ft.

KLS-Martin-Geräte
 → Storz-Endoskope

KLS Martin units
 → Storz endoscopes

Aparatos KLS Martin/
 → Endoscopios Storz

Appareils KLS Martin/
 → Endoscopes Storz

Apparecchi KLS Martin/
 → Endoscopi Storz



80-288-53-04 **max. 600 V_p**
 5 m/16 ft.

KLS-Martin-Geräte
 → Valleylab bipolare Pinzetten

KLS Martin units
 → Valleylab bipolar forceps

KLS Martin
 → Pinzas bipolares Valleylab

appareils KLS Martin
 → Pincés bipolaires Valleylab

apparecchi KLS Martin
 → Pinze bipolari Valleylab



80-288-55-04 **max. 600 V_p**
 5 m/16 ft.

KLS-Martin-Geräte
 → bipolare Scheren von Ethicon (PowerStar)

KLS Martin units
 → bipolar scissors made by Ethicon (PowerStar)

Equipos KLS Martin
 → tijeras bipolares de Ethicon (PowerStar)

Appareils KLS Martin
 → ciseaux bipolaires de Ethicon (PowerStar)

Apparecchi KLS Martin,
 → forbici bipolari di marca Ethicon (PowerStar)

max. 600 V_p



80-286-30-04 3 m/10 ft.
 maXium® e/ Erbe-Geräte ICC und ACC/VIO
 → bipolare Instrumente
 maXium® e/ ICC and ACC/VIO Erbe units
 → bipolar instruments
 maXium® e/ aparatos Erbe ICC e ACC/VIO
 → instrumentos bipolares
 maXium® e/ appareils Erbe ICC et ACC/VIO
 → instruments bipolaires
 maXium® e/ apparecchi Erbe ICC e ACC/VIO
 → strumenti bipolari



80-286-60-04 4 m/13 ft.
 maXium® e/ Erbe-Geräte ICC und ACC/VIO
 → bipolare Instrumente
 maXium® e/ ICC and ACC/VIO Erbe units
 → bipolar instruments
 maXium® e/ aparatos Erbe ICC e ACC/VIO
 → instrumentos bipolares
 maXium® e/ appareils Erbe ICC et ACC/VIO
 → instruments bipolaires
 maXium® e/ apparecchi Erbe ICC e ACC/VIO
 → strumenti bipolari

NON-CE



80-287-70-04 5 m/16 ft.
 Codman- und Valleylab-Geräte
 → bipolare Instrumente
 Codman and Valleylab units
 → bipolar instruments
 aparatos Codman y Valleylab
 → instrumentos bipolares
 appareils Codman et Valleylab
 → instruments bipolaires
 apparecchi Codman e Valleylab
 → strumenti bipolari



80-287-72-04 5 m/16 ft.
 Codman- und Valleylab-Geräte
 → bipolare Instrumente
 Codman and Valleylab units
 → bipolar instruments
 Aparatos Codman y Valleylab
 → instrumentos bipolares
 Appareils Codman et Valleylab
 → instruments bipolaires
 Apparecchi Codman e Valleylab
 → strumenti bipolari

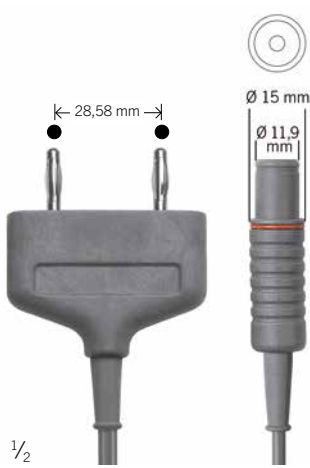

80-287-44-04 3 m/10 ft.
 Geräte mit 2-Pin-International
 → Storz bipolare Instrumente
 Units with 2-pin international
 → Storz bipolar instruments
 Equipos con 2 alfileres, internacional
 → Instrumentos bipolares Storz
 Appareils à 2 broches, international
 → Instruments bipolaires Storz
 Apparecchi a 2 pin, internazionale
 → Strumenti bipolari Storz



80-288-57-04 5 m/16 ft.
 Geräte mit 2-Pin-International
 → bipolare Scheren von Ethicon (PowerStar)
 Units with 2-pin international
 → bipolar scissors made by Ethicon (PowerStar)
 Equipos con 2 alfileres, internacional
 → tijeras bipolares de Ethicon (PowerStar)
 Appareils à 2 broches, international
 → ciseaux bipolaires de Ethicon (PowerStar)
 Apparecchi a 2 pin, internazionale
 → forbici bipolari di marca Ethicon (PowerStar)



max. 600 V_p



80-287-80-04

4 m/13 ft.

KLS-Martin-, Berchtold- und Aesculap-Geräte
 → Aesculap bipolare Instrumente

KLS Martin, Berchtold and Aesculap units
 → Aesculap bipolar instruments

Aparatos KLS Martin, Berchtold y Aesculap
 → instrumentos bipolares Aesculap

Câble de raccordement pour instruments bipolaires
 → instruments bipolaires Aesculap

Apparecchi KLS Martin, Berchtold e Aesculap
 → strumenti bipolari Aesculap



80-286-80-04

4 m/13 ft.

maXium® e/ Erbe-Geräte ICC und ACC/VIO
 → Aesculap bipolare Instrumente

maXium® e/ ICC and ACC/VIO Erbe units
 → Aesculap bipolar instruments

maXium® e/ aparatos Erbe ICC e ACC/VIO
 → instrumentos bipolares Aesculap

maXium® e/ appareils Erbe ICC et ACC/VIO
 → instruments bipolaires Aesculap

maXium® e/ apparecchi Erbe ICC e ACC/VIO
 → strumenti bipolari Aesculap

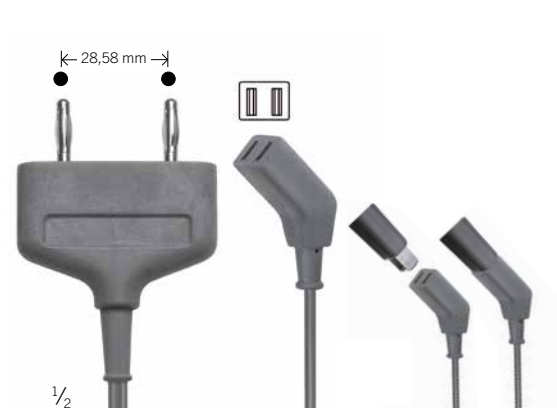

80-288-80-04

4 m/13 ft.

Geräte mit 2-Pin-International
 → Aesculap bipolare Instrumente

Units with 2-pin international
 → Aesculap bipolar instruments

Equipos con 2 alfileres, internacional
 → Instrumentos bipolares Aesculap

Appareils à 2 broches, international
 → Instruments bipolaires Aesculap

Apparecchi a 2 pin, internazionale
 → Strumenti bipolari Aesculap

6



80-287-89-04

3 m/10 ft.

maXium® i, ME MB 3 i, ME MB 2 i /Valleylab-Geräte
 → bipolare Instrumente

maXium® i, ME MB 3 i, ME MB 2 i /Valleylab units
 → bipolare Instrumente

maXium® i, ME MB 3 i, ME MB 2 i /aparatos Valleylab
 → bipolare Instrumente

maXium® i, ME MB 3 i, ME MB 2 i /appareils Valleylab
 → bipolare Instrumente

maXium® i, ME MB 3 i, ME MB 2 i /apparecchi Valleylab
 → bipolare Instrumente

80-287-90-04

5 m/16 ft.



80-288-60-04

4 m/13 ft.

maXium® i, ME MB 3 i, ME MB 2 i /Valleylab-Geräte
 → bipolare Instrumente

maXium® i, ME MB 3 i, ME MB 2 i /Valleylab units
 → bipolare Instrumente

maXium® i, ME MB 3 i, ME MB 2 i /aparatos Valleylab
 → bipolare Instrumente

maXium® i, ME MB 3 i, ME MB 2 i /appareils Valleylab
 → bipolare Instrumente

maXium® i, ME MB 3 i, ME MB 2 i /apparecchi Valleylab
 → bipolare Instrumente

Anschlusskabel für bipolare Resektoskope
 Connecting cables for bipolar resectoscopes
 Cables de conexión para resectoscopios bipolares
 Câbles de raccordement pour résectoscopes bipolaires
 Cavi di collegamento per resettoscopi bipolari

maXium®

Nur verwendbar mit maXium® (ab HW06), sowie Option „Bipolare Resektion“ Art-Nr. 80-093-00-04
 Can be used only with maXium® units (HW06 or higher) and “Bipolar Resection” option, item no. 80-093-00-04
 Sólo puede utilizarse con equipos maXium® (a partir del hardware 06 o superior) y la opción “Resección bipolar”, n.º ref. 80-093-00-04
 Utilisable uniquement avec maXium® (à partir de la version matérielle 06) et avec l'option « Résection bipolaire » réf. 80-093-00-04
 Utilizzabile solo con l'apparecchio maXium® (versione HW06 o superiore) e con l'opzione “Resezione bipolare”, codice art. 80-093-00-04



1/2

80-287-94-04

4 m/13 ft.

maXium® **m/i/e**

→ bipolares Resektoskop Olympus

maXium® **m/i/e**

→ bipolar Olympus resectoscope

maXium® **m/i/e**

→ resectoscopio bipolar Olympus

maXium® **m/i/e**

→ résectoscope bipolaire Olympus

maXium® **m/i/e**

→ resettoscopio bipolare Olympus



1/2

80-287-96-04

4 m/13 ft.

maXium® **m/i/e**

→ bipolares Resektoskop Karl Storz

maXium® **m/i/e**

→ bipolar Karl Storz resectoscope

maXium® **m/i/e**

→ resectoscopio bipolar Karl Storz

maXium® **m/i/e**

→ résectoscope bipolaire Karl Storz

maXium® **m/i/e**

→ resettoscopio bipolare Karl Storz

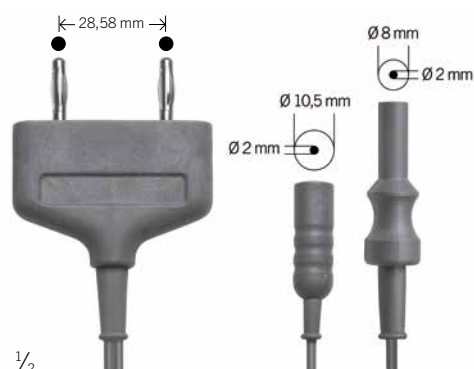

1/2

80-287-95-04

4 m/13 ft.

maXium® **m/i/e**

→ bipolares Resektoskop Richard Wolf

maXium® **m/i/e**

→ bipolar Richard Wolf resectoscope

maXium® **m/i/e**

→ resectoscopio bipolar Richard Wolf

maXium® **m/i/e**

→ résectoscope bipolaire Richard Wolf

maXium® **m/i/e**

→ resettoscopio bipolare Richard Wolf



94-810-28-04 **max. 700 V_p**

Monopolarer Adapter für KLS-Martin-Geräte und Erbe-Zubehör

Monopolar adapter for KLS Martin units and Erbe accessories

Adaptador monopolar para aparatos KLS Martin y accesorios Erbe

Adaptateur monopolaire pour appareils KLS Martin et accessoires Erbe

Adattatore monopolare per apparecchi KLS Martin ed accessori Erbe



80-795-05-04 **max. 700 V_p**

Monopolarer Adapter für KLS-Martin-Geräte und Internationales Zubehör (3-Pin)

Monopolar adapter for KLS Martin units and international accessories (3-pin)

Adaptador monopolar para aparatos KLS Martin y accesorios internacional (3 pin)

Adaptateur monopolaire pour appareils KLS Martin et accessoires international (3 pin)

Adattatore monopolare per apparecchi KLS Martin ed accessori internazionale (3-pin)



80-251-00-04 **max. 700 V_p**

Monopolarer Adapter für KLS-Martin-Geräte und Bovie-Zubehör

Monopolar adapter for KLS Martin units and Bovie accessories

Adaptador monopolar para aparatos KLS Martin y accesorios Bovie

Adaptateur monopolaire pour appareils KLS Martin et accessoires Bovie

Adattatore monopolare per apparecchi KLS Martin ed accessori Bovie

6

NON-CE



80-795-04-04 **max. 4000 V_p**

Monopolarer Adapter mit Bovie-Stecker Für Anschlussstecker 2-4 mm (1-polig)

Monopolar adapter with Bovie connector For 2-4 mm cable connectors (1-pole)

Adaptador monopolar con clavija Bovie Para clavijas de conexión de 2-4 mm (1 polo)

Adaptateur monopolaire avec connecteur Bovie Pour connecteur 2-4 mm (1 pôle)

Adattatore monopolare con connettore Bovie Per connettore 2-4 mm (1 polo)



80-795-03-04 **max. 4000 V_p**

Monopolares Adapterkabel für Erbe-Geräte (ICC, ACC, VIO) und KLS-Martin-Zubehör

Monopolar adapter cable for Erbe units (ICC, ACC, VIO) and KLS Martin accessories

Cable adaptador monopolar para equipos Erbe (ICC, ACC, VIO) y accesorios de KLS Martin

Câble d'adaptateur monopolaire pour appareils Erbe (ICC, ACC, VIO) et accessoires KLS Martin

Cavo adattatore monopolare per apparecchi Erbe (ICC, ACC, VIO) e accessori KLS Martin



80-795-02-04 **max. 700 V_p**

Bipolarer Adapter für KLS-Martin-Geräte und Erbe-Zubehör

Bipolar adapter for KLS Martin units and Erbe accessories

Adaptador bipolar para aparatos KLS Martin y accesorios Erbe

Adaptateur bipolaire pour appareils KLS Martin et accessoires Erbe

Adattatore bipolare per apparecchi KLS Martin ed accessori Erbe



80-796-02-04 **max. 700 V_p**

Bipolares Adapterkabel für KLS-Martin-Geräte
→ Erbe-Zubehör

Bipolar adapter cable for KLS Martin units
→ Erbe accessories

Cable adaptador bipolar para aparatos KLS Martin
→ Accesorios Erbe

Câble adaptateur bipolaire pour appareils KLS Martin
→ Accessoires Erbe

Cavo adattatore bipolare per apparecchi KLS Martin
→ Accessori Erbe



80-793-02-04 **max. 700 V_p**

25 cm/10"

Bipolares Adapterkabel für KLS-Martin-Geräte
→ Codman-/Valleylab-Instrumente

Bipolar adapter cable for KLS Martin units
→ Codman/Valleylab instruments

Cable adaptador bipolar para aparatos KLS Martin
→ Instrumentos Codman/Valleylab

Câble adaptateur bipolaire pour appareils KLS Martin
→ Instruments Codman/Valleylab

Cavo adattatore bipolare per apparecchi KLS Martin
→ Strumenti Codman/Valleylab



80-797-02-04 **max. 700 V_p**

Bipolares Adapterkabel für Erbe-Geräte (ICC, ACC, VIO) und KLS-Martin-Zubehör

Bipolar adapter cable for Erbe units (ICC, ACC, VIO) and KLS Martin accessories

Cable adaptador bipolar para equipos Erbe (ICC, ACC, VIO) y accesorios de KLS Martin

Câble d'adaptateur bipolaire pour appareils Erbe (ICC, ACC, VIO) et accessoires KLS Martin

Cavo adattatore bipolare per apparecchi Erbe (ICC, ACC, VIO) e accessori KLS Martin



80-794-02-04 **max. 700 V_p**

Bipolarer Adapter für KLS-Martin-Geräte („i“-Version) und Valleylab-Zubehör

Bipolar adapter for KLS Martin units (“i“-version) and Valleylab accessories

Adaptador bipolar para aparatos KLS Martin (versión “i”) y accesorios Valleylab

Adaptateur bipolaire pour appareils KLS Martin (version «i») et accessoires Valleylab

Adattatore bipolare per apparecchi KLS Martin (versione “i”) ed accessori Valleylab



80-796-03-04 **max. 700 V_p**

Adapter für Neutralelektrode mit I-Stecker 6,3 mm-NE-Buchse

Adapter for neutral electrode with I-clip, for 6.3-mm NE socket

Adaptador para placa neutra con clavija I, para hembrilla de PN de 6,3 mm

Adaptateur pour électrode neutre avec connecteur I, pour fiche EN 6,3 mm

Adattatore per elettrodo neutro con spina I, per presa EN da 6,3 mm

Ab Hardware 06 und Software V 3.394
 From hardware 06 and software V3.394
 A partir del hardware 06 y del software V3.394
 À partir de la version matérielle 06 et de la version logicielle V3.394
 A partire dalla versione hardware 06 e dalla versione software V3.394

max. 2500 V_p

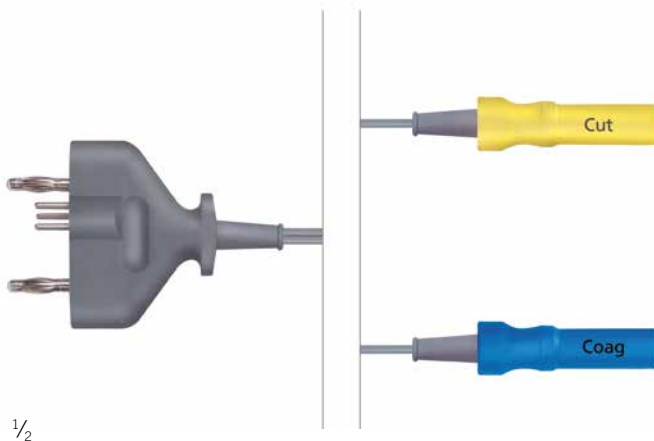

80-790-00-04

Bipolarer Port-Expander für maXium®, Version KLS Martin
 (ab Hardware 06 und Software V3.394), zum Anschluss
 von zwei Instrumentenkabeln mit 8-mm-Koaxstecker

Bipolar port expander for maXium®, KLS Martin version
 (hardware 06 and software V3.394, or higher), for connecting
 two bipolar instrument cables with 8-mm coaxial plugs

Expansor de puerto bipolar para maXium®, versión “KLS Martin”
 (a partir del hardware 06 y del software V3.394, o superior),
 para la conexión de dos cables de instrumento con clavija
 coaxial de 8 mm

Expanseur de port bipolaire pour maXium® version «KLS Martin»
 (à partir de la version matérielle 06 et de la version logicielle
 V3.394), pour le raccordement de deux câbles d’instruments
 bipolaires avec fiches coaxiales de 8 mm

Espansore di porta bipolare per maXium® versione “KLS Martin”
 (a partire dalla versione hardware 06 e dalla versione
 software V3.394), per il collegamento di due cavi per strumenti
 bipolari con spine coassiali da 8 mm

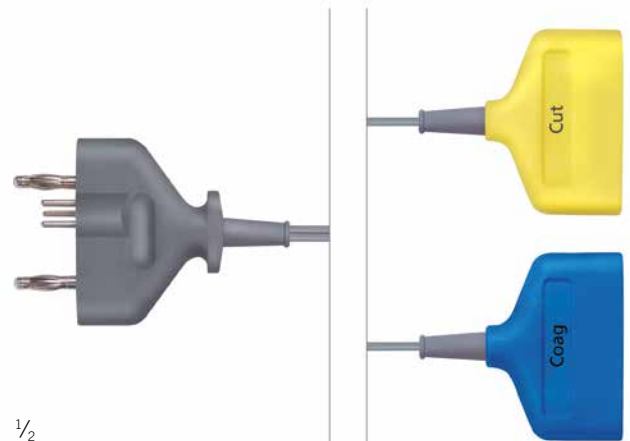

80-790-01-04

Bipolarer Port-Expander für maXium®, Version „international“
 (ab Hardware 06 und Software V3.394), zum Anschluss von
 zwei bipolaren Instrumentenkabeln mit 4-mm-Steckern

Bipolar port expander for maXium®, international version
 (hardware 06 and software V3.394, or higher), for connecting
 two bipolar instrument cables with 4-mm plugs

Expansor de puerto bipolar para maXium®, versión “internacional”
 (a partir del hardware 06 y del software V3.394, o superior),
 para la conexión de dos cables de instrumento bipolares con
 clavijas de 4 mm

Expanseur de port bipolaire pour maXium®, version «international»
 (à partir de la version matérielle 06 et de la version logicielle
 V3.394), pour le raccordement de deux câbles d’instruments
 bipolaires avec fiches de 4 mm

Espansore di porta bipolare per maXium®, versione “internazionale”
 (a partire dalla versione hardware 06 e dalla versione software V3.394),
 per il collegamento di due cavi per strumenti bipolari con spine
 da 4 mm

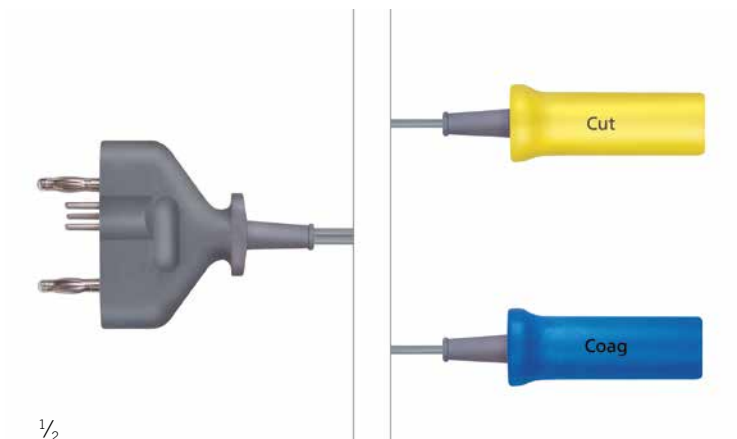

1/2

80-790-02-04

Bipolarer Port-Expander für maXium®, Version Erbe (ab Hardware 06 und Software V3.394), zum Anschluss von zwei bipolaren Instrumentenkabeln mit 12-mm-Koaxstecker

Bipolar port expander for maXium®, Erbe version (hardware 06 and software V3.394, or higher), for connecting two bipolar instrument cables with 12-mm coaxial plugs

Expansor de puerto bipolar para maXium®, versión "Erbe" (a partir del hardware 06 y del software V3.394, o superior), para la conexión de dos cables de instrumento bipolares con clavijas coaxiales de 12 mm

Expanseur de port bipolaire pour maXium®, version «Erbe» (à partir de la version matérielle 06 et de la version logicielle V3.394), pour le raccordement de deux câbles d'instruments bipolaires avec fiches coaxiales de 12 mm

Espansore di porta bipolare per maXium®, versione "Erbe" (a partire dalla versione hardware 06 e dalla versione software V3.394), per il collegamento di due cavi per strumenti bipolari con spine coassiali da 12 mm



6

80-800-00-04





















Kabelmarkierung autoklavierbar, Set bestehend aus drei Farben (gelb, grün, rot)

Cable markers, autoclavable, set including three colors (yellow, green, red)



Marca de cable, autoclavable, juego compuesto de tres colores diferentes (amarillo, verde, rojo)















Marquage pour câbles, autoclavable, set comprenant trois couleurs (jaune, vert, rouge)

Contrassegno per cavo, autoclavabile, set costituito da tre colori diversi (giallo, verde, rosso)





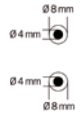

<p>Geräte Units Equipos Appareils Apparecchi</p>	<p>Instrumente Instruments Instrumentos Instruments Strumenti</p>	<p>Olympus</p>			<p>einpolig monopole unipolar monopolaire monopolare</p>
<p>KLS Martin Berchtold Aesculap</p>  		  <p>1/3</p>	 	 	 
<p>maXium® e Erbe ICC Erbe ACC Erbe VIO</p>  		<p>80-289-40-04 4 m/13 ft. max. 4000 V_p</p>	<p>83-120-50-04 5 m/16 ft. max. 4000 V_p</p>		
<p>Erbotom</p>  			<p>83-122-60-04 6 m/20 ft. max. 4000 V_p</p>		
<p>3-Pin maXium® ME MB 3 i ME MB 2 i</p> 		<p>80-289-41-04 4 m/13 ft. max. 4000 V_p</p>	<p>83-120-51-04 5 m/16 ft. max. 4000 V_p</p>	<p>80-290-40-04 4 m/13 ft. max. 4000 V_p</p>	
<p>maXium® ME MB 3 i ME MB 2 i Valleylab</p>  			<p>83-124-50-04 5 m/16 ft. max. 4000 V_p</p>		
<p>einpolig monopole unipolar monopolaire monopolare NON-CE</p>  					<p>80-280-30-04 3 m/10 ft. max. 4000 V_p</p>
<p>KLS Martin Isolit-Pinzetten Isolit forceps Pinzas Isolit Pinces Isolit Pinze Isolit</p>  					



KLS Martin Isolit-Pinzetten Isolit forceps Pinzas Isolit Pinces Isolit Pinze Isolit	Olympus Monopolares Resektoskop Monopolar resectoscope Resectoscopio monopolar Résectoscope monopolaire Resettoscopio monopolare	Richard Wolf Monopolares Resektoskop Monopolar resectoscope Resectoscopio monopolar Résectoscope monopolaire Resettoscopio monopolare	Karl Storz Monopolares Resektoskop Monopolar resectoscope Resectoscopio monopolar Résectoscope monopolaire Resettoscopio monopolare
			
80-285-55-04 4 m/13 ft. max. 4000 V_p	80-286-94-04 4 m/13 ft. max. 4000 V_p	80-286-95-04 4 m/13 ft. max. 4000 V_p	80-286-96-04 4 m/13 ft. max. 4000 V_p
83-124-52-04 4 m/13 ft. max. 4000 V_p			
80-285-40-04 4 m/13 ft. max. 4000 80-285-50-04 5 m/16 ft. max. 4000			

<p>Geräte Units Equipos Appareils Apparecchi</p>	<p>Instrumente Instruments Instrumentos Instruments Strumenti</p>	<p>Europäischer Flachstecker European flat plug Enchufe plano para Europa Fiche plate européenne Spina piatta europea</p>	<p>Europäischer Flachstecker European flat plug Enchufe plano para Europa Fiche plate européenne Spina piatta europea</p>	<p>Karl Storz</p>
<p>KLS Martin Berchtold Aesculap</p>  	<p>1/3</p> 			
<p>maXium® e Erbe ICC Erbe ACC Erbe VIO</p>  	<p>80-287-33-04 3 m/10 ft. max. 600 V_p</p> <p>80-287-53-04 5 m/16 ft. max. 600 V_p</p>	<p>80-291-40-04 4 m/13 ft. max. 850 V_p</p>	<p>80-287-60-04 4 m/13 ft. max. 600 V_p</p>	<p>80-287-42-04 3 m/10 ft. max. 600 V_p</p>
<p>maXium® i maXium® e ME MB 2 i ME MB 3 i Valleylab</p>  	<p>80-286-30-04 3 m/10 ft. max. 600 V_p</p> <p>80-286-50-04 5 m/16 ft. max. 600 V_p</p>	<p>80-286-40-04 4 m/13 ft. max. 850 V_p</p>	<p>80-286-60-04 4 m/13 ft. max. 600 V_p</p>	<p>80-288-60-04 4 m/13 ft. max. 600 V_p</p> <p>80-287-44-04 3 m/10 ft. max. 600 V_p</p>
<p>Codman Valleylab</p>  	<p>80-287-72-04 5 m/16 ft. max. 600 V_p</p>			
<p>Codman Valleylab NON-CE</p>  	<p>80-287-70-04 5 m/16 ft. max. 600 V_p</p>			



<p>Karl Storz Endoskope Endoscopes Endoscopios Endoscopes Endoscopi</p> 	<p>Aesculap Flachstecker/tab connector Tab connector Conector plano/tab connector Connecteur plat/tab connector Connettore piatto/tab connecto</p> 	<p>Valleylab Pinzetten Forceps Pinzas Pincas Pinze</p> 	<p>Ethicon (PowerStar) Scheren Scissors Tijeras Ciseaux Forbici</p> 	<p>Olympus Bipolares Resektoskop Bipolar resectoscope Resectoscopio bipolar Résectoscope bipolaire Resettoscopio bipolare</p> 	<p>Karl Storz Bipolares Resektoskop Bipolar resectoscope Resectoscopio bipolar Résectoscope bipolaire Resettoscopio bipolare</p> 	<p>Richard Wolf Bipolares Resektoskop Bipolar resectoscope Resectoscopio bipolar Résectoscope bipolaire Resettoscopio bipolare</p> 
<p>80-285-51-04 4 m/13 ft. max. 600 V_p</p>	<p>80-287-80-04 4 m/13 ft. max. 600 V_p</p>	<p>80-288-53-04 4 m/13 ft. max. 600 V_p</p>	<p>80-288-55-04 5 m/16 ft. max. 600 V_p</p>			
	<p>80-286-80-04 4 m/13 ft. max. 600 V_p</p>					
	<p>80-288-80-04 4 m/13 ft. max. 600 V_p</p>		<p>80-288-57-04 5 m/16 ft. max. 600 V_p</p>	<p>80-287-94-04 4 m/13 ft. max. 600 V_p</p>	<p>80-287-96-04 4 m/13 ft. max. 600 V_p</p>	<p>80-287-95-04 4 m/13 ft. max. 600 V_p</p>

7

Argon-Beamer-System
Argon Beamer System
Sistema Argon Beamer
Système Argon Beamer
Sistema Argon Beamer



MABS-Handgriff für starre Applikatoren
MABS handle for rigid applicators
Mango MABS para aplicadores rígidos
Manche MABS pour applicateurs rigides
Manipolo MABS per applicatori rigidi

MABS – Das KLS-Martin-Argon-Beamer-System
MABS – The KLS Martin Argon Beamer System
MABS – El sistema KLS Martin Argon Beamer
MABS – Le système KLS Martin Argon Beamer
MABS – Il sistema KLS Martin Argon Beamer



1/2

80-181-02-04 **max. 4000 V_p**

MABS-Handgriff für starre Applikatoren
Zwei Tasten für Koagulation und Schneiden
Anschlusskabel 4,5 m/15 ft. für HF-Strom und Argon-Gas
Autoklavierbar bei 134 °C

MABS handle for rigid applicators
Two pushbuttons for coagulating and cutting
Connection cable 4.5 m/15 ft. in length, for HF current and argon gas
Autoclavable at 134°C

Mango MABS para aplicadores rígidos
Dos teclas para la coagulación y el corte
Cable de conexión de 4,5 m/15 pies para la corriente AF y el gas argón
Autoclavable a 134 °C

Manche MABS pour applicateurs rigides
Deux touches pour coagulation et coupe
Câble de raccordement 4,5 m/15 ft. pour courant HF et gaz d'argon
Peut passer à l'autoclave à 134 °C

Manipolo MABS per applicatori rigidi
Due pulsanti per taglio e coagulazione
Cavo di collegamento di 4,5 m/15 ft. per corrente AF e gas argon
Autoclavabile a 134 °C



1/2

80-181-90-04

MABS-Sterilfilter, VE = 50 Stück
MABS sterile filter, SU = 50/pack
Filtro estéril MABS, UV = 50 piezas
Filtre stérile MABS, UC = 50 unités
Filtro sterile MABS, UV = 50 pezzi



Die MABS-Elektroden haben folgende gemeinsame Eigenschaften:

- Isolierter, starrer Schaft mit einem Durchmesser von 5 mm
- Distale Keramikdüse
- Autoklavierbar bei 134 °C
- Hochtemperaturfeste Zündspitze

Les électrodes MABS présentent les performances communes suivantes:

- Tige rigide, isolée, d'un diamètre de 5 mm
- Buse distale en céramique
- Pouvant passer en autoclave à 134 °C
- Pointe de contact résistant aux températures élevées

All MABS electrodes share the following features:

- Insulated, rigid shaft with a diameter of 5 mm
- Distal ceramic nozzle
- Autoclavable at 134°C
- High-temperature-resistant ignition tip

Gli elettrodi MABS possiedono le seguenti caratteristiche comuni:

- Asta isolato e rigido con un diametro di 5 mm
- Ugello distale di ceramica
- Autoclavabile a 134 °C
- Punta resistente alle elevate temperature

Los electrodos del MABS cuentan con las siguientes características funcionales:

- Varilla aislada y rígida con un diámetro de 5 mm
- Inyector de cerámica distal
- Autoclavable a 134 °C
- Punta de ignición resistente a las altas temperaturas



1/2

80-181-05-04

Fixierkappe, passend für alle starren Elektroden
 Fixing cap, suitable for all rigid electrodes
 Capuchón de fijación, adecuado para todos los electrodos rígidos
 Capuchon de fixation, pour toutes les électrodes rigides
 Cappuccio di fissaggio, per tutti gli elettrodi rigidi



1/2

80-181-10-04 max. 4000 V_p

MABS-Beam-Elektrode für die offene Chirurgie
 Hochtemperaturfeste Zündspitze

MABS beam electrode for open surgery
 High-temperature-resistant ignition tip

Electrodo MABS Beam para la cirugía abierta
 Punta de ignición resistente a las altas temperaturas

Electrode MABS Beam pour la chirurgie ouverte
 Pointe de contact résistant aux températures élevées

Elettrodo MABS Beam per la chirurgia aperta
 Punta resistente alle elevate temperature

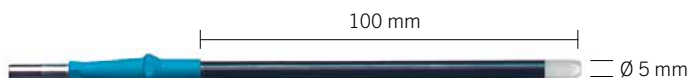

1/2

80-181-11-04 max. 4000 V_p

MABS-Beam-Elektrode für die offene Chirurgie
 Hochtemperaturfeste Zündspitze

MABS beam electrode for open surgery
 High-temperature-resistant ignition tip

Electrodo MABS Beam para la cirugía abierta
 Punta de ignición resistente a las altas temperaturas

Electrode MABS Beam pour la chirurgie ouverte
 Pointe de contact résistant aux températures élevées

Elettrodo MABS Beam per la chirurgia aperta
 Punta resistente alle elevate temperature

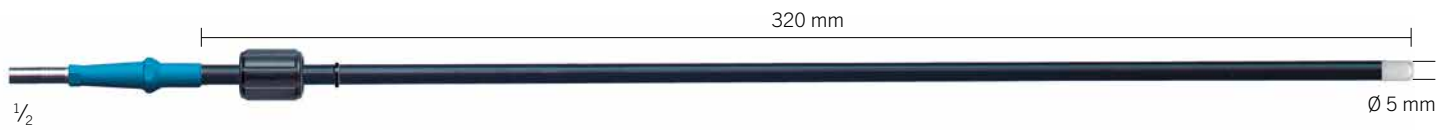

80-181-12-04 max. 4000 V_p

MABS-Beam-Elektrode für die Laparoskopie und Pelviskopie, hochtemperaturfeste Zündspitze, inkl. Fixierkappe

MABS beam electrode for laparoscopy and pelviscopy, high-temperature-resistant ignition tip, incl. fixing cap

Electrodo MABS beam para la laparoscopia y pelviscopia, punta de ignición resistente a las altas temperaturas, incl. capuchón de fijación

Electrode MABS beam pour la laparoscopie et la pelviscopia, pointe de contact résistante aux températures élevées, capuchon de fixation compris

Elettrodo MABS beam per laparoscopia e pelviscopia, punta resistente alle elevate temperature, compreso cappuccio di fissaggio

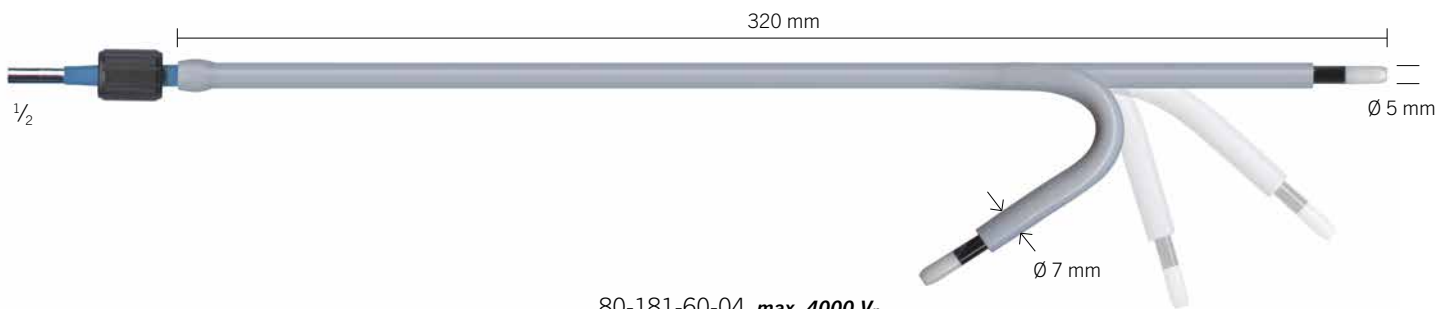

80-181-60-04 max. 4000 V_p

MABS-Beam-Elektrode, 320 mm, biegsam

MABS beam electrode, 320 mm, flexible

Electrodo MABS beam, 320 mm, flexible

Electrode MABS beam, 320 mm, flexible

Elettrodo MABS beam, 320 mm, flessibile

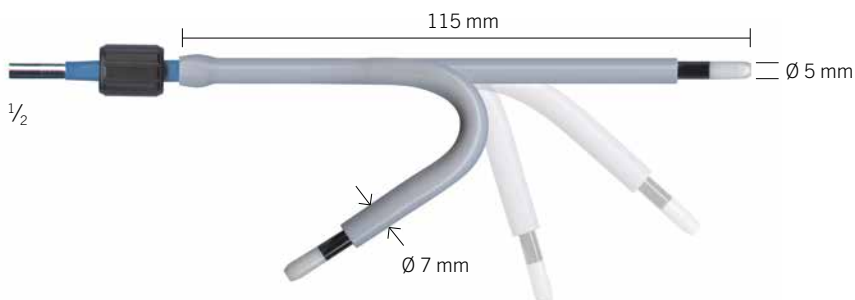

80-181-62-04 max. 4000 V_p

MABS-Beam-Elektrode, 115 mm, biegsam

MABS beam electrode, 115 mm, flexible

Electrodo MABS beam, 115 mm, flexible

Electrode MABS beam, 115 mm, flexible

Elettrodo MABS beam, 115 mm, flessibile



80-181-13-04 **max. 4000 V_p**

MABS-Lanzetten-Elektrode für die offene Chirurgie
 MABS lancet electrode for open surgery
 Electrodo de lanceta MABS para la cirugía abierta
 Electrode couteaux MABS pour la chirurgie ouverte
 Elettrodo a lancetta MABS per la chirurgia aperta



80-181-14-04 **max. 4000 V_p**

MABS-Lanzetten-Elektrode für die offene Chirurgie
 MABS lancet electrode for open surgery
 Electrodo de lanceta MABS para la cirugía abierta
 Electrode couteaux MABS pour la chirurgie ouverte
 Elettrodo a lancetta MABS per la chirurgia aperta



80-181-15-04 **max. 4000 V_p**

MABS-Nadel-Elektrode für die offene Chirurgie
 MABS needle electrode for open surgery
 Electrodo de aguja MABS para la cirugía abierta
 Electrode aiguille MABS pour la chirurgie ouverte
 Elettrodo ad ago MABS per la chirurgia aperta

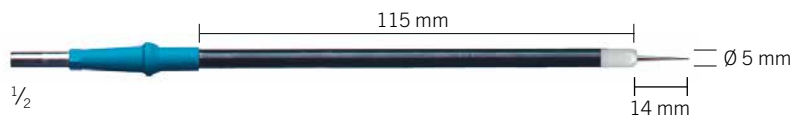

80-181-16-04 **max. 4000 V_p**

MABS-Nadel-Elektrode für die offene Chirurgie
 MABS needle electrode for open surgery
 Electrodo de aguja MABS para la cirugía abierta
 Electrode aiguille MABS pour la chirurgie ouverte
 Elettrodo ad ago MABS per la chirurgia aperta

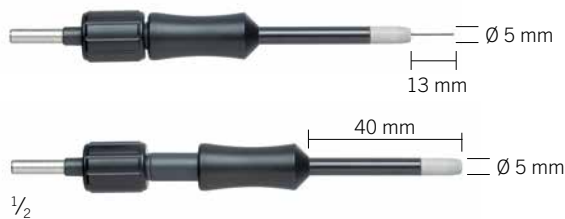

80-181-07-04 **max. 4000 V_p**

MABS-Nadel-Elektrode für die offene Chirurgie, verschiebbar
 MABS needle electrode for open surgery, adjustable
 Electrodo de aguja MABS para la cirugía abierta, regulable
 Electrode aiguille MABS pour la chirurgie ouverte, réglable
 Elettrodo ad ago MABS per la chirurgia aperta, regolabile

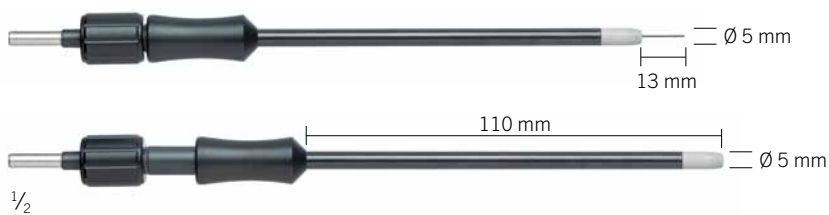

80-181-08-04 **max. 4000 V_p**

MABS-Nadel-Elektrode für die offene Chirurgie, verschiebbar
 MABS needle electrode for open surgery, adjustable
 Electrodo de aguja MABS para la cirugía abierta, regulable
 Electrode aiguille MABS pour la chirurgie ouverte, réglable
 Elettrodo ad ago MABS per la chirurgia aperta, regolabile

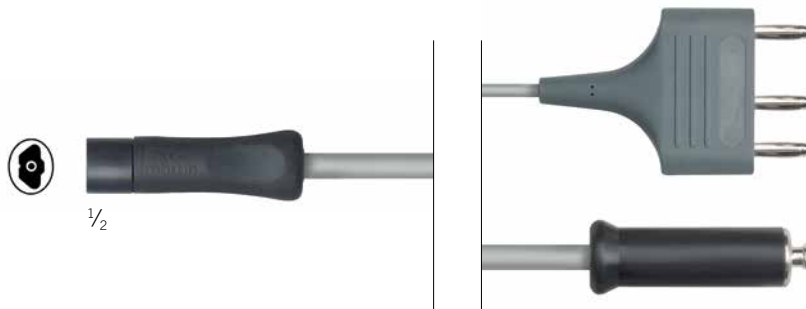

80-181-30-04 max. 4300 V_p

MABS-Anschlussleitung für flexible Sonden (disposable und wiederverwendbar)
 Anschlusskabel 2,5 m, für HF-Strom und Argongas
 HF- und Gas-Aktivierung über Fußschalter
 Autoklavierbar bei 134 °C

MABS connection cable for flexible probes (disposable and reusable)
 Connection cable, 2.5 m, for HF current and argon gas
 HF-current and gas-flow activation via foot switch
 Autoclavable at 134°C

Línea de conexión MABS para sondas flexibles (desechables y reutilizables)
 Cable de conexión de 2,5 m, para corriente AF y gas argón
 Activación AF y del gas por medio del interruptor de pedal
 Autoclavable a 134 °C

Conduite raccord MABS pour sondes flexibles (à usage unique et réutilisables)
 Câble de raccordement, 2,5 m, pour courant HF et gaz d'argon
 Activation HF et gaz par l'intermédiaire d'un interrupteur à pied
 Peut passer à l'autoclave à 134 °C

Cavo di collegamento MABS per sonde flessibili (monouso e riutilizzabili)
 Cavo di collegamento, 2,5 m, per corrente AF e gas argon
 Attivazione AF e gas mediante interruttore a pedale
 Autoclavabile a 134 °C



80-181-90-04

MABS-Sterilfilter, VE = 50 Stück
 MABS sterile filter, SU = 50/pack
 Filtro estéril MABS, UV = 50 piezas
 Filtre stérile MABS, UC = 50 unités
 Filtro sterile MABS, UV = 50 pezzi



80-181-31-04

MABS-Spüladapter für wiederverwendbare Argon-Sonden, VE = 5 Stück
 MABS rinsing adapter for reusable argon probes, SU = 5/pack
 Adaptador de enjuague MABS para sondas argon reutilizables, UV = 5 piezas
 Adaptateur de rinçage MABS pour sondes argon réutilisables, UC = 5 unités
 Adattatore di lavaggio MABS per sonde riutilizzabili, UV = 5 pezzi



MABS flexible Sonden haben folgende gemeinsame Eigenschaften:

- Distale Keramikdüse
- Skaliertes Sondenende
- Autoklavierbar bei 134 °C (nur wiederverwendbare Sonden)
- Um 50 % reduzierter Gasverbrauch (im Vergleich zu bisherigen Sonden)

Les sondes MABS flexibles présentent les caractéristiques communes suivantes:

- Buse distale en céramique
- Extrémité de la sonde graduée
- Peut passer à l'autoclave à 134 °C (seules les sondes sont réutilisables)
- Consommation de gaz réduite de 50 % (par rapport aux anciennes sondes)

All MABS flexible probes have the following features in common:

- Distal ceramic nozzle
- Scaled probe tip
- Autoclavable at 134°C (only reusable probes)
- Reduced gas consumption (50% lower than previous probes)

Le sonde flessibili MABS hanno le seguenti caratteristiche comuni:

- Ugello distale di ceramica
- Estremità della sonda graduata
- Autoclavabile a 134 °C (solo le sonde riutilizzabili)
- Consumo di gas ridotto del 50 % (nei confronti delle sonde avute sinora)

Las sondas flexibles MABS tienen las siguientes características técnicas comunes:







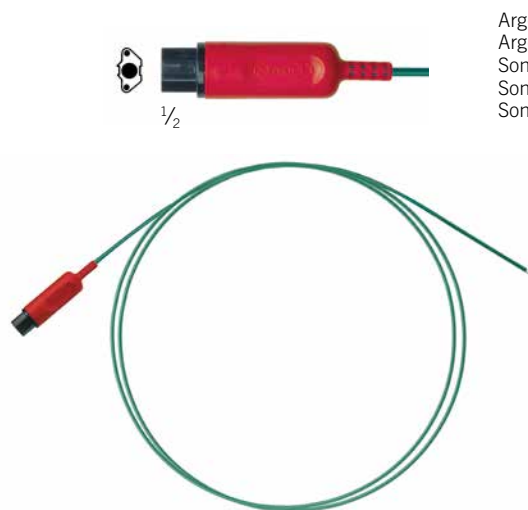

- Inyector de cerámica distal
- Terminación de la sonda escalada
- Autoclavable a 134 °C (sólo las sondas reutilizables)
- Consumo de gas reducido en un 50 % (en comparación con las sondas anteriores)



Argon-Sonde (wiederverwendbar)
 Argon probe (reusable)
 Sonda Argon (reutilizable)
 Sonde Argon (réutilisable)
 Sonda Argon (riutilizzabile)



Argon-Sonde (Einweg)
 Argon probe (disposable)
 Sonda Argon (desechable)
 Sonde Argon (à usage unique)
 Sonda Argon (monouso)

80-181-23-04 max. 4000 V_p					
MABS-GIT-Sonde	Ø 2,3 mm, Länge 2,3 m	wiederverwendbar	(VE 1 Stk.)		
MABS GIT Probe	Ø 2.3 mm, Length 2.3 m	reusable	(1/pack)		
Sonda MABS GIT	Ø 2,3 mm, Largo 2,3 m	reutilizable	(1/unidad)		
Sonde MABS GIT	Ø 2,3 mm, Longueur 2,3 m	réutilisable	(1/unité)		
Sonda MABS GIT	Ø 2,3 mm, Lunghezza 2,3 m	riutilizzabile	(1/unità)		
80-181-24-04 max. 4000 V_p					
MABS-GIT-Sonde	Ø 3,2 mm, Länge 2,3 m	wiederverwendbar	(VE 1 Stk.)		
MABS GIT Probe	Ø 3.2 mm, Length 2.3 m	reusable	(1/pack)		
Sonda MABS GIT	Ø 3,2 mm, Largo 2,3 m	reutilizable	(1/unidad)		
Sonde MABS GIT	Ø 3,2 mm, Longueur 2,3 m	réutilisable	(1/unité)		
Sonda MABS GIT	Ø 3,2 mm, Lunghezza 2,3 m	riutilizzabile	(1/unità)		
80-181-25-04 max. 4000 V_p					
MABS-TBS-Sonde	Ø 1,8 mm, Länge 1,6 m	Einweg	(VE 10 Stk.)		
MABS TBS Probe	Ø 1.8 mm, Length 1.6 m	disposable	(10/pack)		
Sonda MABS TBS	Ø 1,8 mm, Largo 1,6 m	desechable	(10/unidad)		
Sonde MABS TBS	Ø 1,8 mm, Longueur 1,6 m	à usage unique	(10/unité)		
Sonda MABS TBS	Ø 1,8 mm, Lunghezza 1,6 m	monouso	(10/unità)		
80-181-26-04 max. 4000 V_p					 Double balloon enteroscopy
MABS-GIT-Sonde	Ø 1,8 mm, Länge 3,2 m	Einweg	(VE 10 Stk.)		
MABS GIT Probe	Ø 1.8 mm, Length 3.2 m	disposable	(10/pack)		
Sonda MABS GIT	Ø 1,8 mm, Largo 3,2 m	desechable	(10/unidad)		
Sonde MABS GIT	Ø 1,8 mm, Longueur 3,2 m	usage unique	(10/unité)		
Sonda MABS GIT	Ø 1,8 mm, Lunghezza 3,2 m	monouso	(10/unità)		
80-181-27-04 max. 4300 V_p					
MABS-GIT-Sonde	Ø 2,3 mm, Länge 2,3 m	Einweg	(VE 10 Stk.)		
MABS GIT Probe	Ø 2.3 mm, Length 2.3 m	disposable	(10/pack)		
Sonda MABS GIT	Ø 2,3 mm, Largo 2,3 m	desechable	(10/unidad)		
Sonde MABS GIT	Ø 2,3 mm, Longueur 2,3 m	usage unique	(10/unité)		
Sonda MABS GIT	Ø 2,3 mm, Lunghezza 2,3 m	monouso	(10/unità)		
80-181-28-04 max. 4300 V_p					
MABS-GIT-Sonde	Ø 3,2 mm, Länge 2,3 m	Einweg	(VE 10 Stk.)		
MABS GIT Probe	Ø 3.2 mm, Length 2.3 m	disposable	(10/pack)		
Sonda MABS GIT	Ø 3,2 mm, Largo 2,3 m	desechable	(10/unidad)		
Sonde MABS GIT	Ø 3,2 mm, Longueur 2,3 m	usage unique	(10/unité)		
Sonda MABS GIT	Ø 3,2 mm, Lunghezza 2,3 m	monouso	(10/unità)		
80-181-29-04 max. 4300 V_p					 Double balloon enteroscopy
MABS-GIT-Sonde	Ø 2,3 mm, Länge 3,4 m	Einweg	(VE 10 Stk.)		
MABS GIT Probe	Ø 2.3 mm, Length 3.4 m	disposable	(10/pack)		
Sonda MABS GIT	Ø 2,3 mm, Largo 3,4 m	desechable	(10/unidad)		
Sonde MABS GIT	Ø 2,3 mm, Longueur 3,4 m	usage unique	(10/unité)		
Sonda MABS GIT	Ø 2,3 mm, Lunghezza 3,4 m	monouso	(10/unità)		
80-181-32-04 max. 4300 V_p					 Side Fire
MABS-GIT-Sonde	Ø 2,3 mm, Länge 2,3 m	Einweg	(VE 10 Stk.)		
MABS GIT Probe	Ø 2.3 mm, Length 2.3 m	disposable	(10/pack)		
Sonda MABS GIT	Ø 2,3 mm, Largo 2,3 m	desechable	(10/unidad)		
Sonde MABS GIT	Ø 2,3 mm, Longueur 2,3 m	usage unique	(10/unité)		
Sonda MABS GIT	Ø 2,3 mm, Lunghezza 2,3 m	monouso	(10/unità)		

Weitere Informationen entnehmen Sie bitte der separaten Broschüre.

For further information please refer to our separate product brochure.

Encontrará informaciones adicionales en el folleto individual.

Vous trouverez des informations supplémentaires dans la brochure.

Per ulteriori informazioni vedasi il prospetto separato.



MABS-Snare-Sonden „aus ZWEI mach EINS“
 MABS Snare probes – “TWO in ONE”
 Sondas MABS Snare – “DOS en UNA”
 Sondes MABS Snare – «DEUX en UNE»
 Sonde MABS Snare – “DUE in UNA”

Argon-Beamer-System
 Argon Beamer System
 Sistema Argon Beamer
 Système Argon Beamer
 Sistema Argon Beamer



80-181-40-04 max. 4300 V_p

MABS-TBS-Snare-Sonde	Ø 2,5 mm, Länge 1,6 m	15 mm, multifil.,	Einweg	(VE 5 Stk.)
MABS TBS Snare Probe	Ø 2.5 mm, Length 1.6 m	15 mm, multifil.,	disposable	(5/pack)
Sonda MABS TBS Snare	Ø 2,5 mm, Largo 1,6 m	15 mm, multifil.,	desechable	(5/unidad)
Sonde MABS TBS Snare	Ø 2,5 mm, Longueur 1,6 m	15 mm, multifil.,	à usage unique	(5/unité)
Sonda MABS TBS Snare	Ø 2,5 mm, Lunghezza 1,6 m	15 mm, multifil.,	monouso	(5/unità)

80-181-41-04 max. 4300 V_p

MABS-GIT-Snare-Sonde	Ø 2,5 mm, Länge 2,3 m	15 mm, multifil.,	Einweg	(VE 5 Stk.)
MABS GIT Snare Probe	Ø 2.5 mm, Length 2.3 m	15 mm, multifil.,	disposable	(5/pack)
Sonda GIT TBS Snare	Ø 2,5 mm, Largo 2,3 m	15 mm, multifil.,	desechable	(5/unidad)
Sonde GIT TBS Snare	Ø 2,5 mm, Longueur 2,3 m	15 mm, multifil.,	à usage unique	(5/unité)
Sonda GIT TBS Snare	Ø 2,5 mm, Lunghezza 2,3 m	15 mm, multifil.,	monouso	(5/unità)

80-181-42-04 max. 4300 V_p

MABS-GIT-Snare-Sonde	Ø 2,5 mm, Länge 2,3 m	30 mm, multifil.,	Einweg	(VE 5 Stk.)
MABS GIT Snare Probe	Ø 2.5 mm, Length 2.3 m	30 mm, multifil.,	disposable	(5/pack)
Sonda GIT TBS Snare	Ø 2,5 mm, Largo 2,3 m	30 mm, multifil.,	desechable	(5/unidad)
Sonde GIT TBS Snare	Ø 2,5 mm, Longueur 2,3 m	30 mm, multifil.,	à usage unique	(5/unité)
Sonda GIT TBS Snare	Ø 2,5 mm, Lunghezza 2,3 m	30 mm, multifil.,	monouso	(5/unità)

80-181-43-04 max. 4300 V_p

MABS-GIT-Snare-Sonde	Ø 2,5 mm, Länge 2,3 m	15 mm, monofil.,	Einweg	(VE 5 Stk.)
MABS GIT Snare Probe	Ø 2.5 mm, Length 2.3 m	15 mm, monofil.,	disposable	(5/pack)
Sonda GIT TBS Snare	Ø 2,5 mm, Largo 2,3 m	15 mm, monofil.,	desechable	(5/unidad)
Sonde GIT TBS Snare	Ø 2,5 mm, Longueur 2,3 m	15 mm, monofil.,	à usage unique	(5/unité)
Sonda GIT TBS Snare	Ø 2,5 mm, Lunghezza 2,3 m	15 mm, monofil.,	monouso	(5/unità)

80-181-44-04 max. 4300 V_p

MABS-GIT-Snare-Sonde	Ø 2,5 mm, Länge 2,3 m	30 mm, monofil.,	Einweg	(VE 5 Stk.)
MABS GIT Snare Probe	Ø 2.5 mm, Length 2.3 m	30 mm, monofil.,	disposable	(5/pack)
Sonda GIT TBS Snare	Ø 2,5 mm, Largo 2,3 m	30 mm, monofil.,	desechable	(5/unidad)
Sonde GIT TBS Snare	Ø 2,5 mm, Longueur 2,3 m	30 mm, monofil.,	à usage unique	(5/unité)
Sonda GIT TBS Snare	Ø 2,5 mm, Lunghezza 2,3 m	30 mm, monofil.,	monouso	(5/unità)

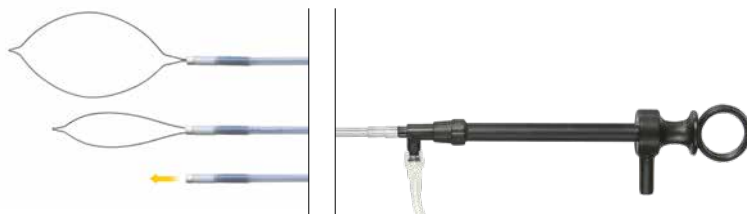

Die MABS-Snare-Sonden sind Kombinationssonden, die für die Abtragung von Polypen und eine anschließende Koagulation mittels Argonbeam verwendet werden können.

MABS Snare probes are combination probes allowing you to remove polyps with subsequent argon coagulation of the site.

Las sondas MABS Snare son sondas combinadas, que pueden utilizarse para la remoción de pólipos y una coagulación posterior mediante plasma de gas argón.

Les sondes MABS Snare sont des sondes combinées qui peuvent être utilisées pour l'ablation de polypes suivie d'une coagulation moyennant un faisceau d'argon.

Le sonde MABS Snare sono sonde combinate che consentono la rimozione di polipi con successiva coagulazione ad argon del sito.

Weitere Informationen entnehmen Sie bitte der separaten Broschüre.

For further information please refer to our separate product brochure.

Encontrará informaciones adicionales en el folleto individual.

Vous trouverez des informations supplémentaires dans la brochure.

Per ulteriori informazioni vedasi il prospetto separato.



80-289-40-04 max. 4000 V_p
 4 m/13 ft.

Monopolares Anschlusskabel für KLS-Martin-HF-Geräte
 Monopolar connecting cable for KLS Martin HF units
 Cable de conexión monopolar para equipos de AF de KLS Martin
 Câble de raccordement monopolaire pour appareils HF KLS Martin
 Cavo di collegamento monopolare per apparecchi AF di KLS Martin



80-289-41-04 max. 4000 V_p
 4 m/13 ft.

Monopolares Anschlusskabel für HF-Geräte mit 3-Pin-Stecker
 Monopolar connecting cable for HF units with 3-pin plugs
 Cable de conexión monopolar para equipos de AF con clavija de 3 patillas
 Câble de raccordement monopolaire pour appareils HF avec fiche à 3 broches
 Cavo di collegamento monopolare per apparecchi AF con spina a 3-spire

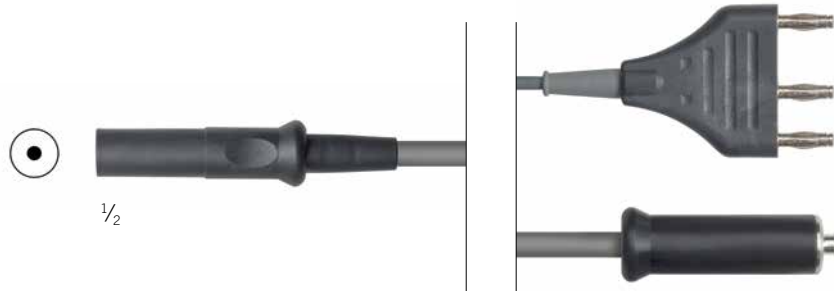

80-181-17-04 **max. 4300 V_p**

MABS-Anschlussleitung für Erbe-Sonden, mit Rundstecker
 MABS connection cable for Erbe probes, with circular connector
 Cable de conexión MABS para sondas Erbe, con clavija redonda
 Câble de connexion MABS pour sondes Erbe, avec connecteur rond
 Cavo di collegamento MABS per sonda Erbe, con spina tonda



80-181-90-04

MABS-Sterilfilter, VE = 50 Stück
 MABS sterile filter, SU = 50/pack
 Filtro estéril MABS, UV = 50 piezas
 Filtre stérile MABS, UC = 50 unités
 Filtro sterile MABS, UV = 50 pezzi

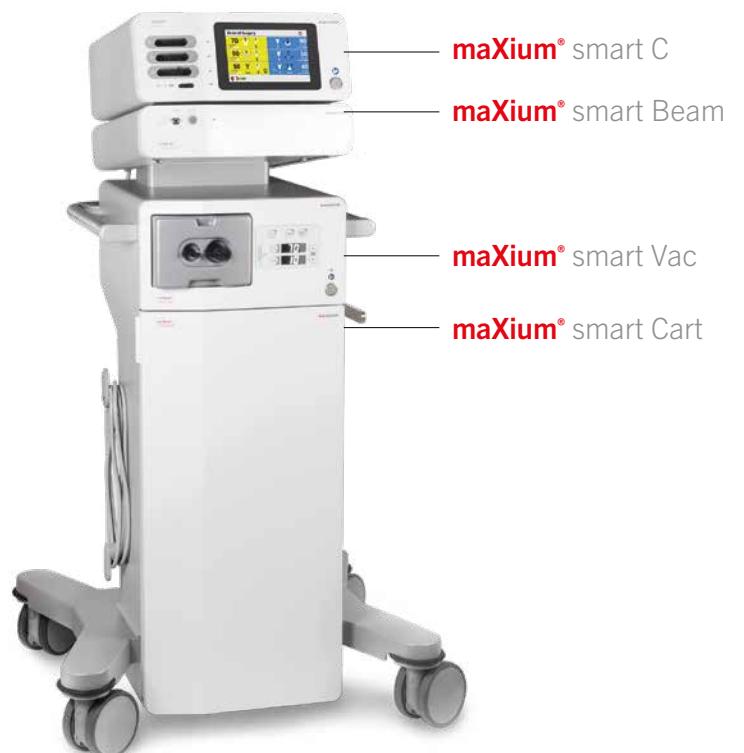
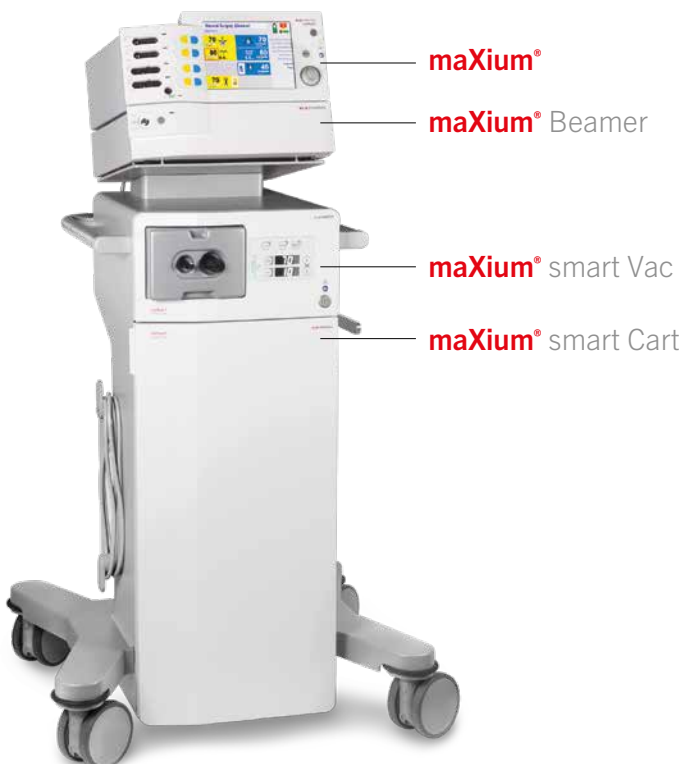



Artikel Item no. Artículo Article Articolo	Norm Standard Norma Norme Norma	Länder Countries Países Pays Paesi
80-181-52-04	DIN 477, Nr. 6	D, A, CH, F, P, E, GR
80-181-53-04	DIN 477, Nr. 10	NL, DK, S, NOR, B
80-181-54-04	UNI 4412	I
80-181-55-04	BS 341, Nr. 3	UK, AUS, MY, IN, TR, former Commonwealth
80-181-56-04	CGA, Nr. 580	USA, MX, TH, South America
80-181-57-04		China

MABS-Druckminderer mit Schlauch und Schnellkupplung 2,5 bis 4,5 bar, Schlauchlänge 1,2 m/3 ft.
MABS pressure reducer with flexible tube and quick-action coupling 2.5 to 4.5 bar, tube length: 1.2 m/3 ft.
Manorreductor MABS con tubo y acoplamiento rápido 2,5 a 4,5 bar, longitud del tubo: 1,2 m/3 pies
Décompresseur MABS avec tuyau et raccord pompier 2,5 à 4,5 bar, longueur de tuyau 1,2 m/3 ft.
Riduttore di pressione MABS con tubo flessibile e attacco rapido da 2,5 a 4,5 bar, lunghezza tubo 1,2 m/3 ft.

MABS-Anschluss an zentrale Argon-Versorgung
MABS connection to central argon supply
Conexión MABS al suministro central de argón
Raccord MABS à l'alimentation centrale en gaz argon
Attacco MABS all'alimentazione centrale di argon

92-800-74-04

MABS-Verbindungsschlauch, mit Vierkant
MABS connection tubing, with square
Tubo de conexión MABS, conector cuadrado
Tubulure de connexion MABS, avec carré
Tubo di connessione MABS, con raccordo quadrato

94-179-58-04

Gasflasche mit Füllung Argongas 4.8, 5 ltr.
Gas bottle with "4.8 quality" argon gas filling, 5 ltr.
Bombona de gas con relleno de gas argón 4.8, 5 ltr.
Bouteille de gaz avec remplissage de gaz d'argon 4.8, 5 ltr.
Bombola di gas con riempimento di gas argon 4.8, 5 ltr.



94-179-59-04

Argon-Gasflasche, ohne Füllung, 5 ltr.
Argon gas cylinder, empty, 5 ltr.
Bombona de gas argón, vacía, 5 ltr.
Bouteille de gaz d'argon, vide, 5 ltr.
Bombola di gas argon, vuota, 5 ltr.

oder über den örtlichen Lieferanten erhältlich
or available through your local supplier
o pueden obtenerse a través del proveedor local
ou disponibles auprès des fournisseurs locaux
o disponibili presso il fornitore locale

Bitte besondere Versandvorschriften beachten!
Please note special shipping regulations!
¡Rogamos tengan en cuenta las disposiciones especiales de envío!
Expédition soumise à des dispositions réglementaires particulières!
Si prega di osservare le particolari prescrizioni per la spedizione!

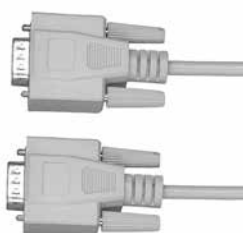

ME 411
ME CD1

80-181-50-04

1 m/3 ft.
MABS-Schnittstellenkabel
MABS interface cable
Cable de interfaz MABS
Câble interface MABS
Cavo interfaccia MABS



ME MB 3/ME MB 2/ME MB 1

Fremdgeräte mit dieser
Steckerverbindung

Third-party devices with this type
of connector

Aparatos de otros fabricantes con
esta conexión de enchufe

Appareils externes avec cette
connexion des prises

Apparecchi di altri produttori con
questa connessione della spina

80-181-51-04

MABS-Verbindungskabel
MABS connecting cable
Cable de conexión MABS
Câble de connexion MABS
Cavo di collegamento MABS

	Technisches Zubehör	Technical accessories	Accesorios técnicos
	Kombination	Combination	Combinación
80-048-00-04	maXium® smart Cart	maXium® smart Cart	maXium® smart Cart
80-048-04-04	Geräteaufnahme maXium® auf maXium® smart Cart	Support maXium® to maXium® smart Cart	Alojamiento aparato maXium® en maXium® smart Cart
80-048-05-04	Gasflaschenhalter für maXium® smart Cart	Support for argon gas cylinder	Sop. para cilindro de gas para maXium® smart Cart
80-044-00-04	maXium® Beamer	maXium® Beamer	maXium® Beamer
	zu wählen	to be selected	a seleccionar
80-042-00-04	maXium® m	maXium® m	maXium® m
80-042-02-04	maXium® i	maXium® i	maXium® i
80-042-04-04	maXium® e	maXium® e	maXium® e

	Kombination	Combination	Combinación
80-048-00-04	maXium® smart Cart	maXium® smart Cart	maXium smart Cart
80-048-03-04	Geräteaufnahme smartLine auf maXium® smart Cart	Support smartLine to maXium® smart Cart	Alojamiento aparato smartLine en maXium® smart Cart
80-048-05-04	Gasflaschenhalter für maXium® smart Cart	Support for argon gas cylinder	Sop. para cilindro de gas para maXium® smart Cart
80-043-10-04	maXium® smart Beam	maXium® smart Beam	maXium® smart Beam
	zu wählen	to be selected	a seleccionar
80-043-00-04	maXium® smart C m	maXium® smart C m	maXium® smart C m
80-043-01-04	maXium® smart C i	maXium® smart C i	maXium® smart C i
80-043-02-04	maXium® smart C e	maXium® smart C e	maXium® smart C e

	Druckmindererauswahl (nach Länderstandard)	Selection of pressure reducers (acc. to national standards)	Selección de manorreductores (según los estándares de países)
80-181-52-04	MABS-Druckminderer, DIN 477 Nr. 6, für D, A, CH, F, P, E, GR	MABS pressure reducer, DIN 477 No. 6, for D, A, CH, F, P, E, GR	Manorreductor MABS, DIN 477 N.º 6, para D, A, CH, F, P, E, GR
80-181-53-04	MABS-Druckminderer, DIN 477 Nr. 10, für NL, DK, S, NOR, B	MABS pressure reducer, DIN 477 No. 10, for NL, DK, S, NOR, B	Manorreductor MABS, DIN 477 N.º 10, para NL, DK, S, NOR, B
80-181-54-04	MABS-Druckminderer, UNI 4412, für I	MABS pressure reducer, UNI 4412, for I	Manorreductor MABS, UNI 4412, para I
80-181-55-04	MABS-Druckminderer, BS 341 Nr. 3, für GB, AUS, Malaysia, Indien, ehem. Commonwealth, Türkei	MABS pressure reducer, BS 341 No. 3, for GB, AUS, Malaysia, India, former Commonwealth, Turkey	Manorreductor MABS, BS 341 N.º 3, para GB, AUS, Malasia, India, ex-Comunidad Británica de Naciones, Turquía
80-181-56-04	MABS-Druckminderer, CGA Nr. 580, für USA, Südamerika, Mexiko, Thailand	MABS pressure reducer, CGA No. 580, for USA, South America, Mexico, Thailand	Manorreductor MABS, CGA Nr. 580, para EE.UU., Sudamérica, México, Tailandia
80-181-57-04	MABS-Druckminderer, China	MABS pressure reducer, China	Manorreductor MABS, China

	Klinisches Zubehör (starr) für die offene Chirurgie (Ø 5 mm)	Clinical accessories (rigid) for open surgery (Ø 5 mm)	Accesorios clínicos (rígidos) para la cirugía abierta (Ø 5 mm)
80-181-02-04	MABS-Handgriff, für starre Elektroden	MABS handle, for rigid electrodes	Interruptor de mango MABS, para electrodos rígidos
80-181-10-04	MABS-Beam-Elektrode, Arbeitslänge 25 mm	MABS beam electrode, working length 25 mm	Electrodo MABS Beam, longitud de trabajo: 25 mm
80-181-11-04	MABS-Beam-Elektrode, Arbeitslänge 100 mm	MABS beam electrode, working length 100 mm	Electrodo MABS Beam, longitud de trabajo: 100 mm
80-181-13-04	MABS-Lanzetten-Elektrode, Arbeitslänge 25 mm	MABS lancet electrode, working length 25 mm	Electrodo MABS de lanceta, longitud de trabajo: 25 mm
80-181-14-04	MABS-Lanzetten-Elektrode, Arbeitslänge 115 mm	MABS lancet electrode, working length 115 mm	Electrodo MABS de lanceta, longitud de trabajo: 115 mm
80-181-15-04	MABS-Nadel-Elektrode, Arbeitslänge 40 mm	MABS needle electrode, working length 40 mm	Electrodo MABS de aguja, longitud de trabajo: 40 mm
80-181-16-04	MABS-Nadel-Elektrode, Arbeitslänge 115 mm	MABS needle electrode, working length 115 mm	Electrodo MABS de aguja, longitud de trabajo: 115 mm



	Accessoires techniques	Accessori tecnici
	Combinaison	Combinazione
80-048-00-04	maXium® smart Cart	maXium® smart Cart
80-048-04-04	Logement maXium® sur maXium® smart Cart	Supporto per maXium® su maXium® smart Cart
80-048-05-04	Porte-bouteille pour maXium® smart Cart	Supporto bombola gas per maXium® smart Cart
80-044-00-04	maXium® Beamer	maXium® Beamer
	A choisir	da selezionare
80-042-00-04	maXium® m	maXium® m
80-042-02-04	maXium® i	maXium® i
80-042-04-04	maXium® e	maXium® e
	Combinaison	Combinazione
80-048-00-04	maXium® smart Cart	maXium® smart Cart
80-048-03-04	Logement smartLine sur maXium® smart Cart	Supporto per smartLine su maXium® smart Cart
80-048-05-04	Porte-bouteille pour maXium® smart Cart	Supporto bombola gas per maXium® smart Cart
80-043-10-04	maXium® smart Beam	maXium® smart Beam
	A choisir	da selezionare
80-043-00-04	maXium® smart C m	maXium® smart C m
80-043-01-04	maXium® smart C i	maXium® smart C i
80-043-02-04	maXium® smart C e	maXium® smart C e

	Choix de décompresseurs (selon les standards nationaux)	Selezione dei riduttori di pressione (in base agli standard nazionali)
80-181-52-04	Décompresseur MABS, DIN 477 n° 6, pour D, A, CH, F, P, E, GR	Riduttore di pressione MABS, DIN 477 N. 6, per D, A, CH, F, P, E, GR
80-181-53-04	Décompresseur MABS, DIN 477 n° 10, pour NL, DK, S, NOR, B	Riduttore di pressione MABS, DIN 477 N. 10, per NL, DK, S, NOR, B
80-181-54-04	Décompresseur MABS, UNI 4412, pour I	Riduttore di pressione MABS, UNI 4412, per I
80-181-55-04	Décompresseur MABS, BS 341 n° 3, pour GB, AUS, Malaisie, Inde, ancien Commonwealth, Turquie	Riduttore di pressione MABS, BS 341 N. 3, per GB, AUS, Malesia, India, ex. Commonwealth, Turchia
80-181-56-04	Décompresseur MABS, CGA n° 580, pour USA, Amérique du sud, Mexique, Thaïlande	Riduttore di pressione MABS, CGA N. 580, per USA, Sudamerica, Messico, Thailandia
80-181-57-04	Décompresseur MABS, Chine	Riduttore di pressione MABS, China

	Accessoires cliniques (rigides) pour la chirurgie ouverte (Ø 5 mm)	Accessori clinici (rigidi) per la chirurgia aperta (Ø 5 mm)
80-181-02-04	Poignée MABS, pour électrodes rigides	Impugnatura MABS, per elettrodi rigidi
80-181-10-04	Electrode du diffuseur MABS, longueur de travail 25 mm	Elettrodo MABS Beam, lunghezza di lavoro 25 mm
80-181-11-04	Electrode du diffuseur MABS, longueur du travail 100 mm	Elettrodo MABS Beam, lunghezza di lavoro 100 mm
80-181-13-04	Electrode à couteau MABS, longueur de travail 25 mm	Elettrodo a lancetta MABS, lunghezza di lavoro 25 mm
80-181-14-04	Electrode à couteau MABS, longueur de travail 115 mm	Elettrodo a lancetta MABS, lunghezza di lavoro 115 mm
80-181-15-04	Electrode à aiguille MABS, longueur de travail 40 mm	Elettrodo ad ago MABS, lunghezza di lavoro 40 mm
80-181-16-04	Electrode à aiguille MABS, longueur de travail 115 mm	Elettrodo ad ago MABS, lunghezza di lavoro 115 mm

	Klinisches Zubehör (starr) für die laparoskopische Chirurgie (Ø 5 mm)	Clinical accessories (rigid) for laparoscopic surgery	Accesorios clínicos (rígidos) para la cirugía laparoscópica
80-181-02-04	MABS-Handgriff, für starre Elektroden	MABS handle, for rigid electrodes	Interruptor de mango MABS, para electrodos rígidos
80-181-12-04	MABS-Beam-Elektrode, Arbeitslänge 320 mm	MABS beam electrode, working length 320 mm	Electrodo MABS Beam, longitud de trabajo: 320 mm

	Klinisches Zubehör (flexibel) für die endoskopische Chirurgie	Clinical accessories (flexible) for endoscopic surgery	Accesorios clínicos (flexibles) para la cirugía endoscópica
80-181-30-04	MABS-Anschlussleitung	MABS connection cable	Cable de conexión MABS
80-181-25-04	MABS-TBS-Sonde, flexibel, Einweg (Ø 1,8 mm/Länge 1,6 m)	MABS TBS probe, flexible, disposable, Ø 1.8 mm, working length 1.6 m	Sonda MABS TBS, flexible, desechable, Ø 1,8 mm/ longitud de trabajo: 1,6 m
80-181-23-04	MABS-GIT-Sonde, flexibel, wiederverwendbar (Ø 2,3 mm/Länge 2,3 m)	MABS GIT probe, flexible, reusable, Ø 2.3 mm, working length 2.3 m	Sonda MABS GIT, flexible, reutilizable, Ø 2,3 mm/ longitud de trabajo: 2,3 m
80-181-24-04	MABS-GIT-Sonde, flexibel, wiederverwendbar (Ø 3,2 mm/Länge 2,3 m)	MABS GIT probe, flexible, reusable, Ø 3.2 mm, working length 2.3 m	Sonda MABS GIT, flexible, reutilizable, Ø 3,2 mm/ longitud de trabajo: 2,3 m
	alternativ: Einwegsonden, flexibel, siehe Seite 110	alternatively: Disposable probes, flexible, see page 110	alternativa: Sondas desechables, flexibles, véase página 110

	Optional	Optional	Accesorios opcionales
80-181-51-04	MABS-Fußschaltersignalkabel	MABS foot switch signal cable	Cable de señalización para el interruptor de pedal MABS
80-821-02-04	MABS-Fußschalter (monopolar), schwere Ausführung	MABS foot switch (monopolar), heavy-duty design	Interruptor de pedal MABS (monopolar), modelo pesado
80-811-30-04	MABS-Fußschalter (monopolar), leichte Ausführung	MABS foot switch (monopolar), light-duty design	Interruptor de pedal MABS (monopolar), modelo ligero
80-294-40-04	Anschlusskabel für Einmal-Neutralelektroden	Connection cable for disposable neutral electrodes	Cable de conexión para electrodos neutros de uso único
80-181-90-04	Sterilfilter, VE = 50 Stck.	Sterile filter, SU = 50/pack	Filtro estéril, UV = 50 piezas

Hinweise:

1. Für die Gewährleistung eines kontinuierlichen OP-Ablaufs sind die klinikinternen Aufbereitungszyklen zu berücksichtigen. Das Zubehör ist vor diesem Hintergrund entsprechend zu quantifizieren.

2. Argongas 4.8 in handelsüblicher Flaschenform (5 l oder 10 l) ist bei den örtlichen Lieferanten erhältlich.

Notes:

1. Smooth OR processes require the seamless integration of the hospital's instrument processing cycles and, consequently, the availability of a sufficient quantity of accessories.

2. "4.8 quality" argon gas may be obtained from local suppliers (to be delivered in commonly used 5-l or 10-l cylinders).

Indicaciones:

1. Para garantizar el desarrollo continuado de las secuencias en el quirófano, deberán tenerse en cuenta los ciclos de procesamiento internos de la clínica. Las cantidades de accesorios deberán planificarse en consecuencia.

2. El gas argón 4.8 se obtiene de los proveedores locales en las bombonas de gas usuales (de 5 ó 10 litros).



	Accessoires cliniques (rigides) pour la chirurgie laparoscopique	Accessori clinici (rigidi) per la chirurgia laparoscopica
80-181-02-04	Poignée MABS, pour électrodes rigides	Impugnatura MABS, per elettrodi rigidi
80-181-12-04	Électrode du diffuseur MABS, longueur de travail 320 mm	Elettrodo MABS Beam, lunghezza di lavoro 320 mm

	Accessoires cliniques (flexibles) pour la chirurgie endoscopique	Accessori clinici (flessibili) per la chirurgia endoscopica
80-181-30-04	Conduite de raccord MABS	Cavo di collegamento MABS
80-181-25-04	Sonde MABS TBS, flexible, à usage unique , Ø 1,8 mm/longueur de travail 1,6 m	Sonda MABS TBS, flessibile, monouso Ø 1,8 mm/lunghezza di lavoro 1,6 m
80-181-23-04	Sonde MABS GIT, flexible, réutilisable Ø 2,3 mm/longueur de travail 2,3 m	Sonda MABS GIT, flessibile, riutilizzabile Ø 2,3 mm/lunghezza di lavoro 2,3 m
80-181-24-04	Sonde MABS GIT, flexible, réutilisable Ø 3,2 mm/longueur de travail 2,3 m	Sonda MABS GIT, flessibile, riutilizzabile Ø 3,2 mm/lunghezza di lavoro 2,3 m
	ou bien: Sondes à usage unique, flexibles, voir page 110	come alternativa: Sonde monouso, flessibili, vedi pagina 110

	En option	Opzioni
80-181-51-04	Câble signal pour interrupteur à ped MABS	Cavo di segnale per l'interruttore a pedale MABS
80-821-02-04	Interrupteur à pied MABS (monopolaire), modèle lourd	Interruttore a pedale MABS (monopolare), esecuzione pesante
80-811-30-04	Interrupteur à pied MABS (monopolaire), modèle léger	nterruttore a pedale MABS (monopolare), esecuzione leggera
80-294-40-04	Câble raccord pour des électrodes neutres à usage unique	Cavo di collegamento per elettrodi neutri monouso
80-181-90-04	Filtre stérile, UC = 50 pièces	Filtro sterile, UV = 50 pezzi

Indications:

1. Il convient de tenir compte des cycles de traitement cliniques internes pour assurer la continuité des processus en salle d'opération. Par conséquent, il faudra veiller à toujours disposer d'accessoires en nombre suffisant.

2. Le gaz d'argon 4.8 est disponible dans des bouteilles à gaz usuelles dans le commerce (5 l ou 10 l) auprès des fournisseurs locaux.

Avvertenze

1. Per garantire un intervento operatorio continuato, devono essere considerati i cicli di preparazione interni. Gli accessori devono essere quantificati in base a queste esigenze.

2. Il gas argon 4.8 in bombole comuni (da 5 o 10 litri) può essere acquistato presso i fornitori locali.

Rauchgasabsaugung und Zubehör
Smoke evacuator and accessories
Evacuación de gases de combustión y accesorios
Évacuateur de fumée et accessoires
Aspiratore di fumo e accessori

8





- | | | | | |
|---------------|-----------|------------|-------------|------------|
| ✓ Effektiv | Effective | Efectivo | Performant | Effettivo |
| ✓ Ergonomisch | Ergonomic | Ergonómico | Ergonomique | Ergonomico |
| ✓ Sicher | Safe | Seguro | Sûr | Sicuro |

marVac® – das innovative System zur effizienten Absaugung von Rauchgasen

marVac® – the innovative system for efficient removal of surgical plume

marVac® – el sistema innovador para la evacuación eficiente de gases de combustión

marVac® – le système innovatif pour l'évacuation efficace des fumées

	marVac® Produktbeschreibung	marVac® Product Description	marVac® Descripción de producto
80-060-00-04	Rauchgasabsaugung marVac® 220–240 V inkl. Hauptfilter (Art.-Nr. 80-060-01-04) und Verbindungssatz für HF-Grossgeräte	marVac® smoke evacuator, 220–240 V, incl. main filter (item no. 80-060-01-04) and connection kit for major electrosurgery units	Evacuación de gases de combustión marVac®, 220 – 240 V, incl. filtro principal (n.º ref. 80-060-01-04) y juego de conexión para gran aparatos
80-060-00-10	Rauchgasabsaugung marVac® 100–127 V inkl. Hauptfilter (Art.-Nr. 80-060-01-04) und Verbindungssatz für HF-Grossgeräte	marVac® smoke evacuator, 100–127 V, incl. main filter (item no. 80-060-01-04) and connection kit for major electrosurgery units	Evacuación de gases de combustión marVac®, 100 – 127 V, incl. filtro principal (n.º ref. 80-060-01-04) y juego de conexión para gran aparatos
80-061-00-04	Rauchgasabsaugung marVac® mit LAP-Modus , 220–240 V inkl. Hauptfilter (Art.-Nr. 80-060-01-04) und Verbindungssatz für HF-Grossgeräte	marVac® smoke evacuator with LAP mode , 220–240 V, incl. main filter (item no. 80-060-01-04) and connection kit for major electrosurgery units	Evacuación de gases de combustión marVac® con modo LAP , 220 – 240 V, incl. filtro principal (n.º ref. 80-060-01-04) y juego de conexión para gran aparatos
80-061-00-10	Rauchgasabsaugung marVac® mit LAP-Modus , 100–127 V inkl. Hauptfilter (Art.-Nr. 80-060-01-04) und Verbindungssatz für HF-Grossgeräte	marVac® smoke evacuator with LAP mode , 100–127 V, incl. main filter (item no. 80-060-01-04) and connection kit for major electrosurgery units	Evacuación de gases de combustión marVac® con modo LAP , 100 – 127 V, incl. filtro principal (n.º ref. 80-060-01-04) y juego de conexión para gran aparatos



marVac® – il sistema innovativo
per l'aspirazione efficace di gas
di combustione

	marVac® Description du produit	marVac® Descrizione del prodotto
80-060-00-04	Evacuateur de fumée marVac®, 220 – 240 V, y compris filtre principal (réf. 80-060-01-04) et set de connexion pour grands appareils	Aspiratore di fumo marVac®, 220 – 240 V, incl. filtro principale (codice art. 80-060-01-04) e set di collegamento per apparecchi grandi
80-060-00-10	Evacuateur de fumée marVac®, 100 – 127 V, y compris filtre principal (réf. 80-060-01-04) et set de connexion pour grands appareils	Aspiratore di fumo marVac®, 100 – 127 V, incl. filtro principale (codice art. 80-060-01-04) e set di collegamento per apparecchi grandi
80-061-00-04	Evacuateur de fumée marVac® avec mode LAP , 220 – 240 V, y compris filtre principal (réf. 80-060-01-04) et set de connexion pour grands appareils	Aspiratore di fumo marVac®, 220 – 240 V, con modalità LAP , incl. filtro principale (codice art. 80-060-01-04) e set di collegamento per apparecchi grandi
80-061-00-10	Evacuateur de fumée marVac® avec mode LAP , 100 – 127 V, y compris filtre principal (réf. 80-060-01-04) et set de connexion pour grands appareils	Aspiratore di fumo marVac®, 100 – 127 V, con modalità LAP , incl. filtro principale (codice art. 80-060-01-04) e set di collegamento per apparecchi grandi

Weitere Informationen entnehmen Sie bitte der separaten Broschüre.

For further information please refer to our separate product brochure.

Encontrará informaciones adicionales en el folleto individual.

Vous trouverez des informations supplémentaires dans la brochure.

Per ulteriori informazioni vedasi il prospetto separato.





- | | | | | |
|---------------|-----------|------------|-------------|------------|
| ✓ Effektiv | Effective | Efectivo | Performant | Effettivo |
| ✓ Ergonomisch | Ergonomic | Ergonómico | Ergonomique | Ergonomico |
| ✓ Sicher | Safe | Seguro | Sûr | Sicuro |

maXium® smart Vac –
 das innovative System zur
 effizienten Absaugung von
 Rauchgasen

maXium® smart Vac –
 the innovative system for
 efficient removal of surgical
 plume

maXium® smart Vac –
 el sistema innovador para
 la evacuación eficiente de
 gases de combustión

maXium® smart Vac –
 le système innovatif pour
 l'évacuation efficace des
 fumées

	maXium® smart Vac Produktbeschreibung	maXium® smart Vac Product description	maXium® smart Vac Descripción de producto
80-062-00-04	Rauchgasabsaugung maXium® smart Vac mit LAP-Modus , 220–240 V inkl. Hauptfilter (Art.-Nr. 80-060-01-04)	Smoke evacuation system maXium® smart Vac with LAP-Mode , 220–240 V incl. main filter unit (item 80-060-01-04)	Evacuación de gases de combustión maXium® smart Vac con modo LAP , 220–240 V incl. filtro principal (no. ref. 80-060-01-04)
80-062-00-10	Rauchgasabsaugung maXium® smart Vac mit LAP-Modus , 100-127 V inkl. Hauptfilter (Art.-Nr. 80-060-01-04)	Smoke evacuation system maXium® smart Vac with LAP-Mode , 100-127 V incl. main filter unit (item 80-060-01-04)	Evacuación de gases de combustión maXium® smart Vac con modo LAP , 100-127 V incl. filtro principal (no. ref. 80-060-01-04)
80-062-01-04	Rauchgasabsaugung maXium® smart Vac, 220–240 V inkl. Hauptfilter (Art.-Nr. 80-060-01-04)	Smoke evacuation system maXium® smart Vac, 220–240 V incl. main filter unit (item 80-060-01-04)	Evacuación de gases de combustión maXium® smartVac, 220–240 V, incl. filtro principal (no. ref. 80-060-01-04)
80-062-01-10	Rauchgasabsaugung maXium® smart Vac, 100-127 V inkl. Hauptfilter (Art.-Nr. 80-060-01-04)	Smoke evacuation system maXium® smart Vac, 100-127 V incl. main filter unit (item 80-060-01-04)	Evacuación de gases de combustión maXium® smartVac, 100-127 V, incl. filtro principal (no. ref. 80-060-01-04)
	Optionale Komponenten: zu bestellen bei Verwendung der maXium® smart Vac als Stand-Alone-Variante:	Optional components: for ordering when using the maXium® smart Vac as stand-alone version:	Componentes opcionales: se deben encargar si se utiliza maXium® smart Vac como variante independiente:
80-062-05-04	maXium® smart Vac, Gehäusedeckel, Stand-Alone	maXium® smart Vac, housing cover, stand-alone	maXium® smart Vac, tapa, equipo individual
	zu bestellen bei Platzierung der maXium® smart Vac direkt unter dem maXium® smart C (z. B. auf Deckenampel)	for ordering with placement of the maXium® smart Vac immediately below the maXium® smart C (e.g. on ceiling lights)	se debe encargar si se coloca maXium® smart Vac directamente debajo de maXium® smart C (p. ej., en la lámpara de techo)
80-062-06-04	maXium® smart Vac, Gehäusedeckel zur Verbindung mit maXium® smart C	maXium® smart Vac, housing cover for maXium® smart C	maXium® smart Vac, tapa para maXium® smart C

Informationen zum Einbau der maXium® smart Vac in das maXium® smart Cart finden Sie auf den Seiten 182/183 (maXium® smart Cart)

Information for installation of the maXium® smart Vac in the maXium® smart Cart can be found on pages 182/183 (maXium® smart Cart)

Encontrará información sobre la integración de maXium® smart Vac en el maXium® smart Cart en las páginas 182/183 (maXium® smart Cart)



maXium® smart Vac –
il sistema innovativo
per l'aspirazione efficace
di gas di combustione

	maXium® smart Vac Description du produit	maXium® smart Vac Descrizione del prodotto
80-062-00-04	Évacuateur de fumée maXium® smart Vac avec mode LAP , 220–240 V y compris filtre principal (réf. 80-060-01-04)	Aspiratore di fumo maXium® smart Vac con modalità LAP , 220–240 V, incl. filtro principale (codice art. 80-060-01-04)
80-062-00-10	Évacuateur de fumée maXium® smart Vac avec mode LAP , 100-127 V y compris filtre principal (réf. 80-060-01-04)	Aspiratore di fumo maXium® smart Vac con modalità LAP , 100-127 V, incl. filtro principale (codice art. 80-060-01-04)
80-062-01-04	Évacuateur de fumée maXium® smart Vac, 220–240 V y compris filtre principal (réf. 80-060-01-04)	Aspiratore di fumo maXium® smart Vac, 220–240 V, incl. filtro principale (codice art. 80-060-01-04)
80-062-01-10	Évacuateur de fumée maXium® smart Vac, 100-127 V y compris filtre principal (réf. 80-060-01-04)	Aspiratore di fumo maXium® smart Vac, 100-127 V, incl. filtro principale (codice art. 80-060-01-04)
	Composants facultatifs: à commander en cas d'utilisation du maXium® smart Vac à titre de variante autonome :	Componenti opzionali: da ordinare in caso d'impiego del maXium® smart Vac come variante stand-alone:
80-062-05-04	maXium® smart Vac, couvercle, solution autonome	maXium® smart Vac, coperchio, stand-alone
	à commander en cas de positionnement du maXium® smart Vac directement sous le maXium® smart C (par ex. sur un dispositif plafonnier)	da ordinare per il posizionamento del maXium® smart Vac directement sotto il maXium® smart C (ad es. sulla sospensione a soffitto)
80-062-06-04	maXium® smart Vac, couvercle pour maXium® smart C	maXium® smart Vac, coperchio per maXium® smart C

Des informations relatives à l'intégration du maXium® smart Vac au maXium® smart Cart sont disponibles aux pages 182/183 (maXium® smart Cart)

Per informazioni sull'installazione del maXium® smart Vac nel maXium® smart Cart consultare le pagine 182/183 (maXium® smart Cart)



Weitere Informationen entnehmen Sie bitte der separaten Broschüre.
For further information please refer to our separate product brochure.
Encontrará informaciones adicionales en el folleto individual.
Vous trouverez des informations supplémentaires dans la brochure.
Per ulteriori informazioni vedasi il prospetto separato.

Zubehör		Accessories	Accesorios
	Individuelle Zubehörteile	Optional accessories	Accesorios opcionales
80-060-01-04	Hauptfilter für Rauchgasabsaugung marVac® / maXium® smartVac (ULPA-Standard)	Main filter formarVac® / maXium® smartVac smoke evacuator (ULPA standard)	Filtro principal para la evacuación de gases de combustión marVac® / maXium® smartVac (estándar ULPA)
80-811-50-04	Einpedalfußschalter zur manuellen Aktivierung	Single-pedal foot switch for foot activation	Interruptor de pie de pedal simple para la activación con el pie
80-060-06-04	Adapter zum Anschluss an eine zentrale OP-Absaugung (Ø 22 mm)	Adapter for connection to central evacuation system (Ø 22 mm)	Adaptador para la conexión al sistema de evacuación central del quirófano (Ø 22 mm)

Verbindungsoptionen zur automatischen Aktivierung (HF-Generator oder Laser)		Connection options for automatic activation (via HF generator or laser)	Opciones de conexión para la activación automática (a través del generador de AF o de un equipo láser)
80-091-01-04	MCB-Verbindungskabel (maXium® und maXium® smartVac)	MCB connecting cable (maXium® and maXium® smartVac)	Cable de conexión MCB (maXium® y maXium® smartVac)
80-060-05-04	Adapter zur Netzstromerkennung (ISA-Verbindung), inkl. Verbindungskabel	Adapter for mains current detection (ISA connection), incl. connecting cable	Adaptador para la detección de la corriente de red (conexión ISA), incl. capuchón de fijación
76-100-60-04	Verlängerungskabel maXium® smartVac, MCO-Laser	Extension cable for maXium® smartVac, MCO laser	Cable de prolongación para maXium® smartVac, láser MCO
80-091-02-04	Verbindungskabel ME MB 2/3 mit marVac®/maXium® smartVac	Connection cable ME MB 2/3 with marVac®/maXium® smartVac	Cable de conexión ME MB 2/3 con marVac®/maXium® smartVac
79-800-02-04	Verbindung mit Limax® 60/ diomax® 980/1550	Interlink cable to Limax® 60/ diomax® 980/1550	Cable de interconexión con Limax® 60/ diomax® 980/1550

Weiteres Zubehör für die Rauchgasabsaugung		Additional accessories for smoke evacuator	Accesorios adicionales para el evacuador de gases
79-225-02-04	Trichter, abgeflacht, Verbindung Ø 22 mm, 50 Mal autoklavierbar bei max. 134 °C	Funnel, flattened, connector Ø 22 mm, 50 times autoclavable at max. 134°C (273.2°F)	Embudo, aplanado, conexión Ø 22 mm, autoclavable 50 veces a máx. 134 °C
79-225-03-04	Absaugrohr für Absaugschlauch Ø 22 mm, 50 mal autoklavierbar bei max. 134 °C	Suction tube for suction hose, Ø 22 mm, 50 times autoclavable at max. 134°C (273.2°F)	Tubo de aspiración para la manguera de aspiración de Ø 22 mm, autoclavable 50 veces a máx. 134 °C
79-225-06-04	Schlauchverbinder Ø 22 mm auf Ø 10 mm, 50 Mal autoklavierbar bei max. 134 °C	Hose coupling, Ø 22 mm (f) and Ø 10 mm, 50 times autoclavable at max. 134°C (273.2°F)	Pieza de unión para mangueras, Ø 22 mm a Ø 10 mm, autoclavable 50 veces a máx. 134 °C
79-225-07-04	Schlauchverbinder Ø 22 mm auf Ø 22 mm (m), 50 mal autoklavierbar bei max. 134 °C	Hose coupling, Ø 22 mm (f) and Ø 22 mm, (50 times autoclavable at max. 134°C (273.2°F)	Pieza de unión para mangueras, Ø 22 mm a Ø 22 mm, autoclavable 50 veces a máx. 134 °C
79-225-08-04	Absaugschlauch Ø 22 mm, Länge = 3 m, 50 Mal autoklavierbar bei max. 134 °C	Suction hose, Ø 22 mm, length = 3 m, 50 times autoclavable at max. 134°C (273.2°F)	Manguera de aspiración, Ø 22 mm, longitud = 3 m, autoclavable 50 veces a máx. 134 °C
79-225-09-04	Absaugschlauch Ø 10 mm, Länge = 2 m, 50 Mal autoklavierbar bei max. 134 °C	Suction hose, Ø 10 mm, length = 2 m, 50 times autoclavable at max. 134°C (273.2°F)	Manguera de aspiración, Ø 10 mm, longitud = 2 m, autoclavable 50 veces a máx. 134 °C
79-225-10-04	Steriler Absaugschlauch Ø 22 mm, zur Einmalverwendung (Verpackungseinheit = 25 Stück)	Suction hose, sterile, Ø 22 mm, single-use (pack of 25 items)	Manguera de aspiración, estéril, Ø 22 mm, de un solo uso (unidad de embalaje = 25 unidades)
79-225-11-04	Vorfilter (HEPA-Standard), Ø 22 mm, steril, zum Einmalgebrauch (Verpackungseinheit = 20 Stück)	Prefilter (HEPA standard), Ø 22 mm, sterile, single-use (pack of 20 items)	Filtro previo (estándar HEPA), Ø 22 mm, estéril, de un solo uso (unidad de embalaje = 20 unidades)
80-060-04-04	Absaugschlauch, steril, Ø 10 mm mit Luer-Lock-Anschluss, Länge = 2,5 m, (z.B. zum Anschluss an Trokar) (Verpackungseinheit = 20 Stück)	Air hose, sterile, Ø 10 mm with Luer-Lock connection, 2.5 m long, (e.g. for connection of trocar) (packaging unit = 20 pieces)	Manguera de aspiración, esteril, Ø 10 mm con conector Luer-Lock longitud = 2,5 m (por ej., para la conexión al trocar) (unidad de embalaje = 20 piezas)



Accessoires		Accessori	
Accessoires en option		Accessori individuali	
80-060-01-04	Filtre principal pour évacuateur de fumée marVac®/maXium® smartVa (norme ULPA)	Filtro principale per l'aspiratore di fumo marVac®/maXium® smartVac (standard ULPA)	
80-811-50-04	Interrupteur à une pédale pour activation à l'aide d'une pédale	Interruttore monopedale per l'attivazione a pedale	
80-060-06-04	Adaptateur de raccordement à un système central d'évacuation (Ø 22 mm)	Collegamento all'aspirazione centralizzata della sala operatoria (Ø 22 mm)	
Options de connexion pour activation automatique (via générateur HF ou laser)		Opzioni di collegamento per l'attivazione automatica (tramite generatore AF o apparecchio laser)	
80-091-01-04	Câble de connexion MCB (® et maXium® smartVac)	Cavo di collegamento MCB (maXium® e maXium® smartVac)	
80-060-05-04	Adaptateur de détection de courant secteur (connexion ISA), câble de connexion compris	Adattatore di rilevamento della corrente di rete (collegamento ISA), compreso cavo di collegamento	
76-100-60-04	Rallonge maXium® smartVac, laser MCO	Cavo di prolunga per maXium® smartVac, laser MCO	
80-091-02-04	Câble de connexion ME MB 2/3 avec marVac®/maXium® smartVac	Cavo di collegamento ME MB 2/3 con marVac®/maXium® smartVac	
79-800-02-04	Câble de interconnexion vers Limax® 60/ diomax® 980/1550	Cavo d'interconnessione da Limax® 60/ diomax® 980/1550	
Autres accessoires pour évacuateur de fumée		Ulteriori accessori per l'aspirazione di fumo	
79-225-02-04	Entonnoir, aplati, raccord Ø 22 mm, 50 x autoclavable à max. 134 °C	Imbutto, spianato, collegamento di Ø 22 mm, autoclavabile per 50 volte ad una temperatura di max. 134 °C	
79-225-03-04	Tube d'aspiration pour tuyau d'aspiration Ø 22 mm, 50 x autoclavable à max. 134 °C	Tubo di aspirazione per tubo flessibile di aspirazione di Ø 22 mm, autoclavabile per 50 volte ad una temperatura di max. 134 °C	
79-225-06-04	Raccord de tuyau Ø 22 mm sur Ø 10 mm, 50 x autoclavable à max. 134 °C	Raccordo per tubo flessibile di Ø 22 mm su Ø 10 mm, autoclavabile per 50 volte ad una temperatura di max. 134 °C	
79-225-07-04	Raccord de tuyau Ø 22 mm sur Ø 22 mm, 50 x autoclavable à max. 134 °C	Raccordo per tubo flessibile di Ø 22 mm su Ø 22 mm, autoclavabile per 50 volte ad una temperatura di max. 134 °C	
79-225-08-04	Tuyau d'aspiration Ø 22 mm, longueur = 3 m, 50 x autoclavable à max. 134 °C	Tubo flessibile di aspirazione di Ø 22 mm, lunghezza = 3 m, autoclavabile per 50 volte ad una temperatura di max. 134 °C	
79-225-09-04	Tuyau d'aspiration Ø 10 mm, longueur = 2 m, 50 x autoclavable à max. 134 °C	Tubo flessibile di aspirazione di Ø 10 mm, lunghezza = 2 m, autoclavabile per 50 volte ad una temperatura di max. 134 °C	
79-225-10-04	Tuyau d'aspiration, stérile, Ø 22 mm, à usage unique (UE = 25 pièces)	Tubo flessibile di aspirazione, sterile, Ø 22 mm, monouso (unità di imballaggio = 25 unità)	
79-225-11-04	Préfiltre (norme HEPA), Ø 22 mm, stérile, à usage unique (UE = 20 pièces)	Prefiltro (standard HEPA), Ø 22 mm, sterile, monouso (unità di imballaggio = 20 unità)	
80-060-04-04	Tuyau d'aspiration, stérile, Ø 10 mm avec raccord Luer-Lock, longueur = 2,5 m, (par exemple pour le raccordement au trocart) (unité d'emballage = 20 pièces)	Tubo flessibile di aspirazione di Ø 10 mm, sterile, con raccordo Luer-Lock, lunghezza = 2,5 m, (per esempio per il collegamento al trocart) (unità di imballaggio = 20 unità)	



80-060-03-04 **max. 4100 V_p** **STERILE IEO**

Elektrodenhandgriff mit Elektrode Ø 2,4 mm und 3-Pin-Stecker mit aufgesetztem Clip-on-Applikator, steril, zum Einmalgebrauch, Schlauchlänge = 3 m, Schlauchdurchmesser 22 mm (Verpackungseinheit = 12 Stück)

Electrode handle with electrode Ø 2.4 mm and 3-pin plug, with attached clip-on applicator, sterile, for single use only, hose length 3 m, hose diameter 22 mm (12 items/pack)

Mango portaelectrodos con electrodo de Ø 2,4 mm y clavija de tres alfileres, con aplicador clip-on colocado, estéril, de un solo uso, longitud de la manguera = 3 m, diámetro de la manguera 22 mm (12 unidades/envase)

Manche porte-électrode avec électrode Ø 2,4 mm et fiche à 3 broches, avec applicateur « clip-on » sur le dessus, stérile, à usage unique, longueur du tuyau = 3 m, diamètre du tuyau 22 mm (unité d'emballage = 12 pièces)

Impugnatura per elettrodi con elettrodo Ø 2,4 mm e spina a 3 pin, con applicatore clip-on applicato, sterile, monouso, lunghezza tubo flessibile 3 m, diametro tubo flessibile 22 mm (unità di imballaggio = 12 pezzi)



80-060-02-04 *max. 4000 V_p* **STERILE EO**

Clip-on-Applikator, steril, zum Einmalgebrauch, Schlauchlänge = 3 m, Ø 22 mm zur Verwendung mit den wiederverwendbaren Elektrodenhandgriffen KLS Martin 80-217-XX und 80-210-12-04 (Verpackungseinheit = 12 Stück)*

Clip-on applicator, sterile, single-use, tubing length 3 m, Ø 22 mm, for use with the reusable KLS Martin electrode handles 80-217-XX and 80-210-12-04 (12 items/pack)*

Aplicador "clip-on", estéril, de un solo uso, longitud de manguera 3 m, Ø 22 mm, a utilizar con los mangos portaelectrodos reutilizables de KLS Martin 80-217-XX y 80-210-12-04 (UE = 12 unidades)*

Applicateur « clip-on », stérile, à usage unique, longueur du tuyau 3 m, Ø 22 mm, pour utilisation avec porte-électrode à usage multiple KLS Martin 80-217-XX et 80-210-12-04 (UE = 12 pièces)*

Applicatore "clip-on", sterile, monouso, lunghezza tubo flessibile 3 m, Ø 22 mm, da usare con le impugnature riutilizzabili per elettrodi KLS Martin 80-217-XX e 80-210-12-04 (UV = 12 unità)*

* Die Elektrodenhandgriffe sind nicht im Lieferumfang enthalten und müssen separat bestellt werden.

The electrode handles are not included in the scope of supply and therefore must be ordered separately.

Los mangos portaelectrodos no forman parte de las prestaciones del suministro, debiéndolos encargar por separado.

Les Manches porte-électrodes ne sont pas comprises dans la livraison et doivent être commandées séparément.

Le impugnature per elettrodi non sono comprese nella fornitura e devono essere ordinate separatamente.





smartLap



HF-Anschlusskabel (ø 4 mm)
HF connection cord (ø 4 mm)
Cable de conexión AF (ø 4 mm)
Câble de raccordement HF (ø 4 mm)
Cavo di collegamento AF (ø 4 mm)

Hochwertige Isolierung
Premium quality isolation
Aislación de alta calidad
Isolation de grande qualité
Isolamento di alta qualità

Anschluss für Absaugschlauch
Connector for suction hose
Conexión para tubo de aspiración
Connexion pour tube d'aspiration
Collegamento per tubo d'aspiratore

Integrierter Absaugkanal
Integrated evacuation channel
Canal de aspiración integrado
Conduite d'évacuation intégrée
Canale di aspirazione integrato

Geriffelter Handgriff
Corrugated handpiece
Mango corrugado
Poignée cannelée
Impugnatura scanalata

8

maXium®

maXium® smart Vac/
marVac®



83-120-50-04 **max. 4000 V_p**
5 m/16 ft.

Anschlusskabel
Connection cable
Cable de conexión
Câble de raccordement
Cavo di connessione

83-120-51-04 **max. 4000 V_p**
5 m/16 ft.

Anschlusskabel
Connection cable
Cable de conexión
Câble de raccordement
Cavo di connessione

Nervstimulator
Nerve Stimulator
Estimulador de nervios
Neurostimulateur
Neurostimolatore

9



Nervstimulator NervScout zur intraoperativen Differenzierung von Nerven und Muskeln

NervScout Nerve Stimulator for intraoperative differentiation between nerves and muscles

Estimulador de nervios NervScout para la diferenciación intraoperativa de nervios y músculos

Neurostimulateur NervScout pour faire la différence entre les nerfs et les muscles durant l'intervention chirurgicale

Neurostimolatore NervScout per la differenziazione intraoperatoriadi nervi e muscoli

Der Nervstimulator dient der intraoperativen Differenzierung von Nerven und Muskeln in elektrisch stimulierbaren neuromuskulären Gewebestrukturen.

- Verringerung des Verletzungsrisikos
- Optimierung des Operationsergebnisses

Das Gerät wird als reiner **Stand-alone-Nervstimulator** verwendet.

The nerve stimulator lets you easily differentiate between nerves and muscles in neuromuscular tissue structures that can be stimulated with electric current.

- Reduction of the risk of injury
- Optimization of the surgical outcome

The device can be used either as a **stand-alone nerve stimulator**.

El estimulador de nervios sirve para la diferenciación intraoperativa de nervios y músculos en estructuras de tejidos neuro-musculares eléctricamente estimulables.

- Reducción del riesgo de lesión
- Optimización del resultado de la intervención

El aparato puede utilizarse como **estimulador de nervios en funcionamiento autónomo**.

	Bestelldaten	Ordering Data	Datos de pedido
80-065-00-04	NervScout (220-240 V)	NervScout (220-240 V)	NervScout (220-240 V)
80-217-01-04	Elektroden-Handgriff mit 1 Taste, 4 m Kabel	Electrode handle with 1 button, 4-m cable	Mango portaelectrodos con 1 con mutador, 4 m de cable
80-217-03-04	NeuroPen-Handgriff mit 3 Tasten, 4 m Kabel	NeuroPen handle with 3 buttons, 4-m cable	Mango NeuroPen con 3 con mutadores, 4 m de cable
80-220-00-04	Elektroden-Handgriff ohne Taste, 4 m Kabel	Electrode handle without button, 4-m cable	Mango portaelectrodos sin con mutador, 4 m de cable
80-565-01-04	Stimulationselektrode (versilbert), Ø 1 mm	Stimulation electrode (silver-plated), Ø 1 mm	Electrodo de estimulación (plateado), 1 mm Ø
80-565-02-04	Stimulationselektrode (versilbert), Ø 2 mm	Stimulation electrode (silver-plated), Ø 2 mm	Electrodo de estimulación (plateado), 2 mm Ø
80-565-03-04	Stimulationselektrode (versilbert), Ø 3 mm	Stimulation electrode (silver-plated), Ø 3 mm	Electrodo de estimulación (plateado), 3 mm Ø
80-294-44-04	Anschlusskabel für Einmal-Neutralelektroden	Connecting cable for disposable neutral electrodes	Cable de conexión para placas neutras de un solo uso
80-344-09-04	Einmal-Neutralelektroden	Disposable neutral electrodes	Placas neutras desechables
80-811-50-04	Einpedal-Fußschalter	Single-pedal foot switch	Interruptor de pie monopedal



Weitere Informationen entnehmen Sie bitte der separaten Broschüre.

For further information please refer to our separate product brochure.

Encontrará informaciones adicionales en el folleto individual.

Vous trouverez des informations supplémentaires dans la brochure.

Per ulteriori informazioni vedasi il prospetto separato.

Le neurostimulateur NervScout permet de faire la différence entre les nerfs et les muscles durant l'intervention chirurgicale dans des structures tissulaires neuro-musculaires stimulables électriquement.

- Risque de blessure réduit
- Optimisation du résultat de l'intervention

Le neurostimulateur peut être utilisé **seul**.

Il neurostimolatore viene usato per la differenziazione intraoperatoria di nervi e muscoli in strutture di tessuto neuro-muscolari elettrostimolabili.

- Riduzione del rischio di lesioni
- Ottimizzazione del risultato operatorio

L'apparecchio può essere utilizzato come **neurostimolatore a sé stante**.

	Données de commande	Dati di ordinazione
80-065-00-04	NervScout (220-240 V)	NervScout (220-240 V)
80-217-01-04	Manche porte-électrode à 1 touche, câble de 4 m	Impugnatura per elettrodi con 1 tasto, cavo da 4 m
80-217-03-04	Manche NeuroPen à 3 touches, câble de 4 m	Impugnatura NeuroPen con 3 tasti, cavo da 4 m
80-220-00-04	Manche porte-électrode sans touche, câble de 4 m	Impugnatura per elettrodi senza tasto, cavo da 4 m
80-565-01-04	Électrode de stimulation (argentée), Ø 1 mm	Elettrodo per stimolazione (argentato), Ø 1 mm
80-565-02-04	Électrode de stimulation (argentée), Ø 2 mm	Elettrodo per stimolazione (argentato), Ø 2 mm
80-565-03-04	Électrode de stimulation (argentée), Ø 3 mm	Elettrodo per stimolazione (argentato), Ø 3 mm
80-294-44-04	Câble d'alimentation pour électrodes neutres jetables	Cavo di collegamento per elettrodi neutri monouso
80-344-09-04	Électrodes neutres jetables	Elettrodi neutri monouso
80-811-50-04	Interrupteur à simple pédale	Interruttore monopedale

10

Übersicht der Hochfrequenzchirurgie-Geräte
Overview of electrosurgery units
Resumen de aparatos electroquirúrgicos
Résumé des bistouris électrochirurgicaux
Elenco degli apparecchi elettrochirurgici

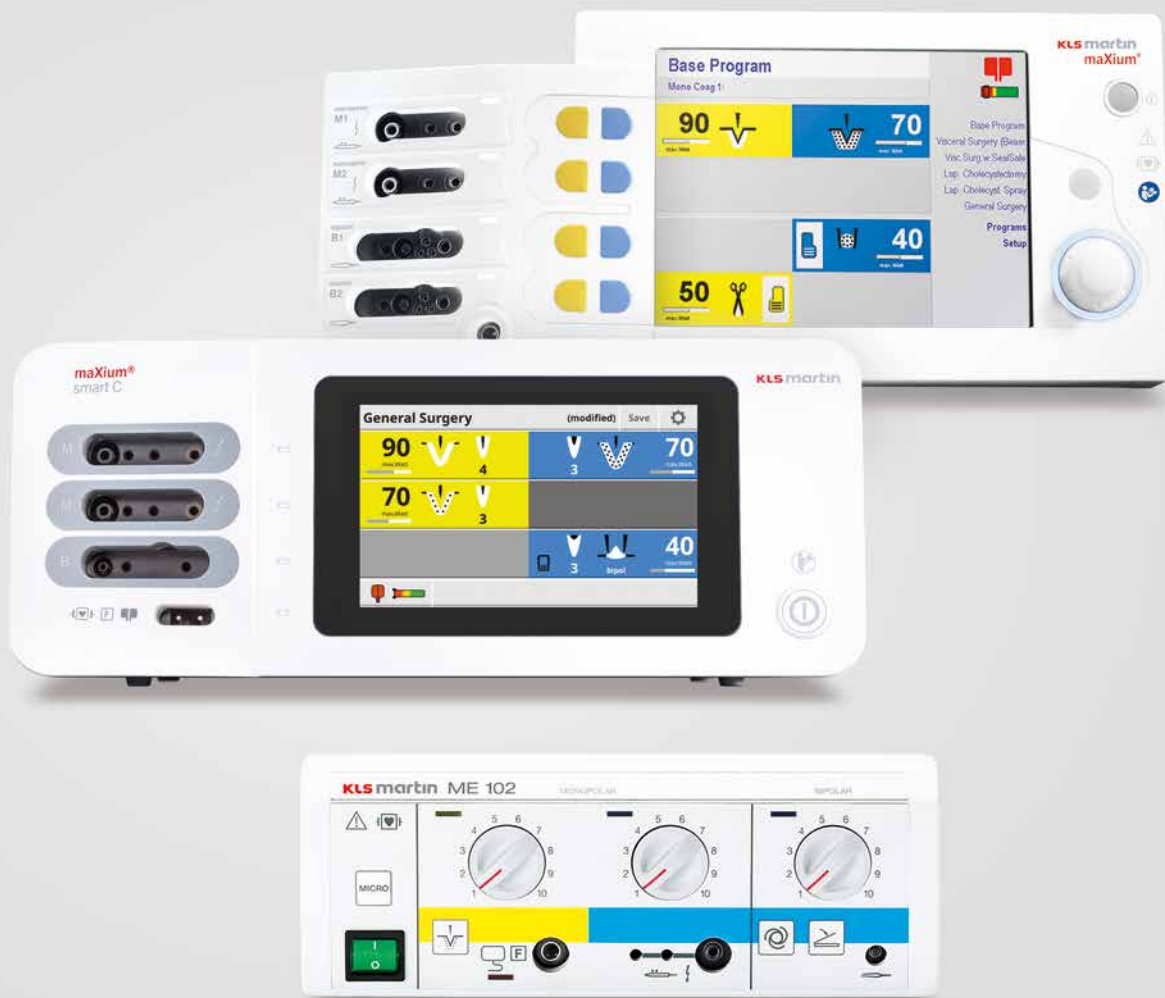

maXium®



80-042-00-04
 maXium® m
 (100-240 V)

80-042-02-04
 maXium® i
 (100-240 V)

80-042-04-04
 maXium® e
 (100-240 V)

80-093-00-04
 maXium®
 Option bipolare Resektion
 Bipolar resection option
 Opción resección bipolar
 Option résection bipolaire
 Opzione resezione bipolare

80-093-01-04
 maXium®
 Option Einbindung in OR1 NEO/Karl Storz
 Option integration into Karl Storz OR1 NEO system
 Opción de integración en el sistema OR1 NEO/Karl Storz
 Option intégration dans le système OR1 NEO/Karl Storz
 Opzione integrazione nel sistema OR1 NEO/Karl Storz

80-093-02-04
 maXium®
 Option Einbindung in CORE nova®/Richard Wolf
 Option integration into CORE nova®/Richard Wolf system
 Opción de integración en el sistema CORE nova®/Richard Wolf
 Option intégration dans le système CORE nova®/Richard Wolf
 Opzione integrazione nel sistema CORE nova®/Richard Wolf

maXium® Beamer



80-044-00-04
 maXium® Beamer
 Nur zur Verwendung mit dem maXium®-Generator
 For use only with the maXium® generator
 Utilícese sólo con generador maXium®
 A n'utiliser qu'avec générateur maXium®
 Solo per l'utilizzo con generatore maXium®



maXium® smart C



reddot award 2016
winner



Focus Open 2016
Special Mention



80-043-00-04
maXium® smart C **m**
(100-240 V)

80-043-01-04
maXium® smart C **i**
(100-240 V)

80-043-02-04
maXium® smart C **e**
(100-240 V)

80-094-00-04
maXium® smart C
Option SWAP-Mode
Option SWAP mode
Opción modo SWAP
Option mode SWAP
Opzione modo SWAP

80-094-01-04
maXium® smart C
Option Duo-Prep, Duo-Spray
Option Duo-Prep, Duo-Spray
Opción Duo-Prep, Duo-Spray
Option Duo-Prep, Duo-Spray
Opzione Duo-Prep, Duo-Spray

80-094-03-04
maXium® smart C
Option Neptun
Option Neptun
Opción Neptun
Option Neptun
Opzione Neptun

maXium® smart Beam



80-043-10-04

Nur zur Verwendung mit den maXium®-smart-Generatoren
 For use only with the maXium® smart generators
 Utilícese sólo con generadores maXium® smart
 A n'utiliser qu'avec générateurs maXium® smart
 Solo per l'utilizzo con generatori maXium® smart

ME MB 3



80-040-11-04
ME MB 3 **m**
(220-240 V)

80-040-12-04
ME MB 3 **i**
(220-240 V)

80-040-11-10
ME MB 3 **m**
(100-127 V)

80-040-12-10
ME MB 3 **i**
(100-127 V)

ME MB 1



80-040-08-04
Endo-Mode
(220-240 V)

80-040-08-10
Endo-Mode
(100-127 V)



ME 102

miniCutter



80-010-02-04
(220-240 V)

80-008-03-04
(220-240 V)

80-010-02-12
(100-127 V)

80-008-03-12
(100-127 V)

MD 62

10



80-006-02-04
(220-240 V)

80-006-02-11
(100-127 V)

Für weitere Informationen fordern Sie bitte die jeweilige Broschüre an.
If you require more information please request the appropriate brochure.
Para más información, solicite el folleto correspondiente.
N'hésitez pas à demander à recevoir la brochure correspondante pour obtenir de plus amples informations.
Per ulteriori informazioni, richiedere le rispettive brochure.

Unit	Max. Output	Monopolar	Bipolar	Benutzer- oberfläche	Aktivierung	NE - Modes	Argon-Gas	Rauchgas- absaugung	Gefäßver- siegelung
MD 62	Monopolar 50 Watt (Cut) 30 Watt (Coag)	1 Cut 1 Coag	-	Analoganzeige (Drehregler)	Elektroden-Handgriff mit einer Taste oder Einpedal- Fußschalter, pneumatisch	Handzylinder- Neutral- elektrode		maXium® smart Vac oder marVac® mit iDetect	
miniCutter	Monopolar 80 Watt (Cut) 70 Watt (Coag) Bipolar 70 Watt	2 Cut 2 Coag	1 Coag	Analoganzeige (Drehregler)	Monopolar Elektroden-Handgriff mit einer Taste oder Einpedal-Fußschalter Bipolar Aktivierung nur über Einpedal-Fußschalter			maXium® smart Vac oder marVac® mit iDetect	
ME 102	Monopolar 100 Watt (Cut) 70 Watt (Coag) Bipolar 80 Watt	2 Cut 1 Coag	1 Coag	Analoganzeige (Drehregler)	Monopolar Elektroden-Handgriff oder Fußschalter Bipolar Aktivierung über Fußschalter oder über „Auto-Start“-Funktion			maXium® smart Vac oder marVac® mit iDetect	
ME MB 1	Monopolar 400 Watt (Cut) 250 Watt (Coag) Bipolar 100 Watt	3 Cut 2 Coag	1 Coag	Analoganzeige (Drehregler)	Monopolar Elektroden-Handgriff oder Fußschalter Bipolar Aktivierung nur über Fußschalter		MB 181	maXium® smart Vac oder marVac® mit iDetect	
ME MB 3	Monopolar 400 Watt (Cut) 250 Watt (Coag) Bipolar 100 Watt	4 Cut 3 Coag	1 Coag	Digitalanzeige (Drehregler)	Monopolar Elektroden-Handgriff oder Fußschalter Bipolar Aktivierung über Fußschalter oder über „Auto-Start“- Funktion		MB 181	maXium® smart Vac oder marVac® mit iDetect	
maXium® smart C	Monopolar 400 Watt (Cut) 200 Watt (Coag) Bipolar 120 Watt (Cut) 250 Watt (Coag)	6 Cut 9 Coag	2 Cut 2 Coag	Digitalanzeige (Touch-Screen Display)	Monopolar Elektroden-Handgriff oder Fußschalter Bipolar: Aktivierung über Fußschalter oder über „Auto-Start“- Funktion	 Baby Mega	maXium® smart Beam	maXium® smart Vac	
maXium®	Monopolar 360 Watt (Cut) 150 Watt (Coag) Bipolar 120 Watt (Cut) 320 Watt (Coag)	13 Cut 17 Coag	7 Cut 13 Coag	Digitalanzeige (Display mit Drehregler)	Monopolar Elektroden-Handgriff oder Fußschalter Bipolar Aktivierung über Fußschalter oder über Fingerschalter. Alternativ über „Auto-Start“-Funktion	 Baby Mega	maXium® Beamer	marVac® oder maXium® smart Vac mit maXium® smart Cart	SealSafe IQ

Übersicht
Anschlusskabel

Großer Koaxialstecker

Kleiner Koaxialstecker

Erbe Koaxialstecker Ø 8 mm

US-3-PIN-Stecker





TUR	Schnittstelle für HF-Zubehör	Anwendungsbereiche																			
		Allgemeinchirurgie	Dentalchirurgie	Dermatologie	Gastroenterologie	Gynäkologie	Herz- und Gefäßchirurgie	HNO-Chirurgie	Mund-, Kiefer- und Gesichtschirurgie	Neurochirurgie	Urologie	Viszeralchirurgie									
	1 monopolarer Ausgang • Großer Koaxialstecker	x																			
	1 monopolarer Ausgang • Großer Koaxialstecker 1 bipolarer Ausgang • Kleiner Koaxialstecker	x	x	x						x	x										
	1 monopolarer Ausgang • Großer Koaxialstecker • US-3-PIN-Stecker 1 bipolarer Ausgang • Kleiner Koaxialstecker	x	x	x						x	x										
mono- polare TUR	1 monopolarer Ausgang • Großer Koaxialstecker • US-3-PIN-Stecker 1 bipolarer Ausgang • Kleiner Koaxialstecker	x							x	x									x	x	
mono- polare TUR	m-Version 1 monopolarer Ausgang • Großer Koaxialstecker • US-3-PIN-Stecker • Bananenstecker 1 bipolarer Ausgang • US-2-PIN-Flachstecker • Kleiner Koaxialstecker	i-Version 1 monopolarer Ausgang • US-3-PIN-Stecker • Bananenstecker 1 bipolarer Ausgang • US-2-PIN-Flachstecker • Kleiner Koaxialstecker	x																x	x	
mono- polare TUR	m-Version 2 monopolare Ausgänge • Großer Koaxialstecker • US-3-PIN-Stecker • Bananenstecker 1 bipolarer Ausgang • US-2-PIN-Flachstecker • Kleiner Koaxialstecker • Bananenstecker	i-Version 2 monopolare Ausgänge • Bovie-Stecker • US-3-PIN-Stecker • Bananenstecker 1 bipolarer Ausgang • US-2-PIN-Flachstecker • Großer Koaxialstecker • Bananenstecker	e-Version 2 monopolare Ausgänge • Erbe-Koaxialstecker • US-3-PIN-Stecker • Bananenstecker 1 bipolarer Ausgang • US-2-PIN-Flachstecker • Großer Koaxialstecker • Bananenstecker	x																	
Bipolare TUR und mono- polare TUR	m-Version 2 monopolare Ausgänge • Großer Koaxialstecker • US-3-PIN-Stecker • Bananenstecker 2 bipolare Ausgänge • US-2-PIN-Flachstecker • Kleiner Koaxialstecker • Bananenstecker • IQ-Stecker	i-Version 2 monopolare Ausgänge • Bovie-Stecker • US-3-PIN-Stecker • Bananenstecker 2 bipolare Ausgänge • US-2-PIN-Flachstecker • Bananenstecker • IQ-Stecker	e-Version 2 monopolare Ausgänge • Erbe-Koaxialstecker • US-3-PIN-Stecker • Bananenstecker 2 bipolare Ausgänge • US-2-PIN-Flachstecker • Großer Koaxialstecker • Bananenstecker • IQ-Stecker	x																	

10



Unit	Max. Output	Monopolar	Bipolar	User interface	Activation	NE-mode	Argon gas	Smoke evacuator	Vessel sealing
MD 62	Monopolar 50 Watt (Cut) 30 Watt (Coag)	1 Cut 1 Coag	-	Analog display (Rotary switch)	Electrode handle with one pushbutton or single-pedal foot switch, pneumatic	Hand cylinder neutral electrode		maXium® smart Vac or marVac® with iDetect	
miniCutter	Monopolar 80 Watt (Cut) 70 Watt (Coag) Bipolar 70 Watt	2 Cut 2 Coag	1 Coag	Analog display (Rotary switch)	Monopolar Electrode handle with one pushbutton or single- pedal foot switch Bipolar Only with single-pedal foot switch			maXium® smart Vac or marVac® with iDetect	
ME 102	Monopolar 100 Watt (Cut) 70 Watt (Coag) Bipolar 80 Watt	2 Cut 1 Coag	1 Coag	Analog display (Rotary switch)	Monopolar Electrode handle or foot switch Bipolar Foot switch or „Auto-Coag-Start“ function			maXium® smart Vac or marVac® with iDetect	
ME MB 1	Monopolar 400 Watt (Cut) 250 Watt (Coag) Bipolar 100 Watt	3 Cut 2 Coag	1 Coag	Analog display (Rotary switch)	Monopolar Electrode handle or foot switch Bipolar Only with foot switch		MB 181	maXium® smart Vac or marVac® with iDetect	
ME MB 3	Monopolar 400 Watt (Cut) 250 Watt (Coag) Bipolar 100 Watt	4 Cut 3 Coag	1 Coag	Digital display (Rotary switch)	Monopolar Electrode handle or foot switch Bipolar Foot switch or „Auto-Coag-Start“ function		MB 181	maXium® smart Vac or marVac® with iDetect	
maXium® smart C	Monopolar 400 Watt (Cut) 200 Watt (Coag) Bipolar 120 Watt (Cut) 250 Watt (Coag)	6 Cut 9 Coag	2 Cut 2 Coag	Digital display (Touch-Screen Display)	Monopolar Electrode handle or foot switch Bipolar Foot switch or „Auto-Coag-Start“ function	 Baby Mega	maXium® smart Beam	maXium® smart Vac	
maXium®	Monopolar 360 Watt (Cut) 150 Watt (Coag) Bipolar 120 Watt (Cut) 320 Watt (Coag)	13 Cut 17 Coag	7 Cut 13 Coag	Digital display (Display with Rotary switch)	Monopolar Electrode handle or foot switch Bipolar Foot switch/ hand activation or „Auto-Coag-Start“ function	 Baby Mega	maXium® Beamer	marVac® or maXium® smart Vac with maXium® smart Cart	SealSafe IQ

Overview
connectin cables

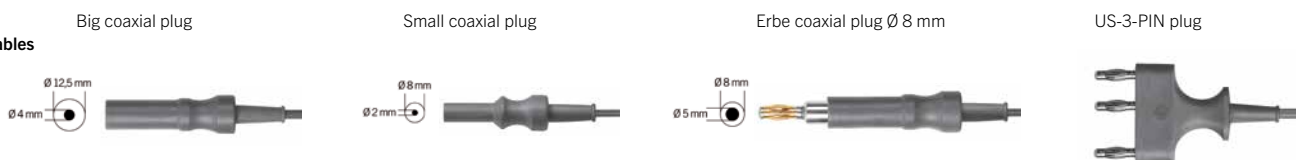



Bipolar resection	Connection socket for HF accessories																				
		Cardiovascular surgery	Dental surgery	Dermatology	ENT surgery	Gastroenterology	General surgery	Gynaecology	Oral and Craniofacial surgery	Neuro surgery	Urology	Visceral surgery									
	1 monopolar output • Big coaxial plug	x																			
	1 monopolar output • Big coaxial plug 1 bipolar output • Small coaxial plug	x	x	x		x			x		x										
	1 monopolar output • Big coaxial plug • US-3-PIN plug 1 bipolar output • Small coaxial plug	x	x	x		x			x		x										
mono-polar TUR	1 monopolar output • Big coaxial plug • US-3-PIN plug 1 bipolar output • Small coaxial plug							x	x	x					x	x					
mono-polar TUR	m-Version 1 monopolar output • Big coaxial plug • US-3-PIN plug • Banana plug 1 bipolar output • US-2-PIN plug • Small coaxial plug																				
	i-Version 1 monopolar output • US-3-PIN plug • Banana plug 1 bipolar output • US-2-PIN plug • Small coaxial plug																				
	e-Version 2 monopolar outputs • Erbe coaxial plug • US-3-PIN plug • Banana plug 1 bipolar output • US-2-PIN plug • Big coaxial plug • Banana plug																				
mono-polar TUR	m-Version 2 monopolar outputs • Big coaxial plug • US-3-PIN plug • Banana plug 1 bipolar output • US-2-PIN plug • Small coaxial plug • Banana plug	x																			
	i-Version 2 monopolar outputs • Bovie plug • US-3-PIN plug • Banana plug 1 bipolar output • US-2-PIN plug • Big coaxial plug • Banana plug																				
	e-Version 2 monopolar outputs • Erbe coaxial plug • US-3-PIN plug • Banana plug 1 bipolar output • US-2-PIN plug • Big coaxial plug • Banana plug																				
Bipolar TUR and mono-polar TUR	m-Version 2 monopolar outputs • Big coaxial plug • US-3-PIN plug • Banana plug 2 bipolar outputs • US-2-PIN plug • Small coaxial plug • Banana plug • IQ plug	x																			
	i-Version 2 monopolar outputs • Bovie plug • US-3-PIN plug • Banana plug 2 bipolar outputs • US-2-PIN plug • Banana plug • IQ plug																				
	e-Version 2 monopolar outputs • Erbe coaxial plug • US-3-PIN plug • Banana plug 2 bipolar outputs • US-2-PIN plug • Big coaxial plug • Banana plug • IQ plug																				

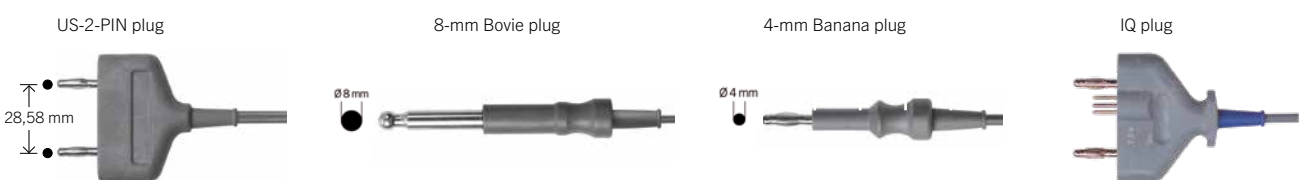



80-105-00-04

Prüfgerät marTest bestehend aus:

- Prüferät marTest
- Netzteil Europa, 100-240 V
- Leitungssatz zur Isolationsprüfung für MIC-Instrumente mit 4-mm-Anschluss
- Koffer zur Aufbewahrung

marTest tester comprised of:

- marTest tester
- Power supply unit Europe, 100-240 V
- Cable set for insulation testing on MIS instruments with 4 mm socket
- Storage case

Comprobador marTest compuesto por:

- Comprobador marTest
- Fuente de alimentación, Europa, 100-240 V
- Juego de cables para la comprobación del aislamiento para instrumentos CMI con conexión de 4 mm
- Maletín (para guardar el aparato)

Dispositif testeur marTest, comprenant

- Appareil testeur marTest
- Bloc d'alimentation, Europe, 100-240 V
- Lot de câbles pour vérification de l'isolation des instruments de chirurgie mini-invasive, avec connecteur de 4-mm
- Mallette de rangement

Apparecchio di prova marTest composto da:

- Apparecchio di prova marTest
- Alimentatore, Europa, 100-240 V
- Set di cavi per prova di isolamento di strumenti per chirurgia mininvasiva con presa di 4 mm
- Valigetta per conservazione

**Optionales Zubehör
Optional accessories
Accesorios opcionales
Accessoires en option
Accessori opzionali**



1/3

80-105-01-04

Adapter zur Isolationsprüfung für bipolare Instrumente mit europäischem Flachpin-Stecker

Adapter for insulation testing on bipolar instruments with European flat-pin connector

Adaptador para la comprobación del aislamiento para instrumentos bipolares con clavija de pin plano europea

Adaptateur pour vérification de l'isolation des instruments bipolaires avec connecteur pin plat européen

Adattatore per prova di isolamento di strumenti bipolari con connettore a spina piatta europea



1/3

80-105-02-04

Adapter zur Prüfung bipolares Resektoskopkabel Karl Storz (Art.-Nr. 80-287-96-04)

Adapter for testing bipolar resectoscope cable Karl Storz (item no. 80-287-96-04)

Adaptador para la comprobación del cable de resectoscopio bipolar Karl Storz (n.º art. 80-287-96-04)

Adaptateur pour contrôle du câble pour résectoscope bipolaires Karl Storz (réf. 80-287-96-04)

Adattatore per la prova del cavo di resettoscopio bipolare Karl Storz (codice 80-287-96-04)



1/3

80-105-05-04

Leitungssatz zur Isolationsprüfung von MIC-Instrumenten mit 4-mm-Anschluss (bereits im Lieferumfang von Art. 80-105-00-04 enthalten)

Cable set for insulation testing on MIS instruments with 4-mm socket (already included with art. 80-105-00-04)

Juego de cables para la comprobación del aislamiento para instrumentos CMI con conexión de 4 mm (ya incluido en el volumen de suministro del art. 80-105-00-04)

Lot de câbles pour vérification de l'isolation des instruments de chirurgie mini-invasive, avec connecteur de 4 mm (déjà fourni avec l'article 80-105-00-04)

Set di cavi per prova di isolamento di strumenti per chirurgia mininvasiva con presa di 4 mm (già presente nella dotazione dell'art. 80-105-00-04)



1/3

80-105-03-04

Netzteil Europa, 100 -240 V (bereits im Lieferumfang von Art. 80-105-00-04 enthalten)

Power supply Europe, 100-240 V (already included with art. 80-105-00-04)

Fuente de alimentación Europa, 100-240 V (ya incluido en el volumen de suministro del art. 80-105-00-04)

Bloc d'alimentation Europe, 100-240 V (déjà fourni avec l'article 80-105-00-04)

Alimentatore Europa, 100 -240 V (già presente nella dotazione dell'art. 80-105-00-04)

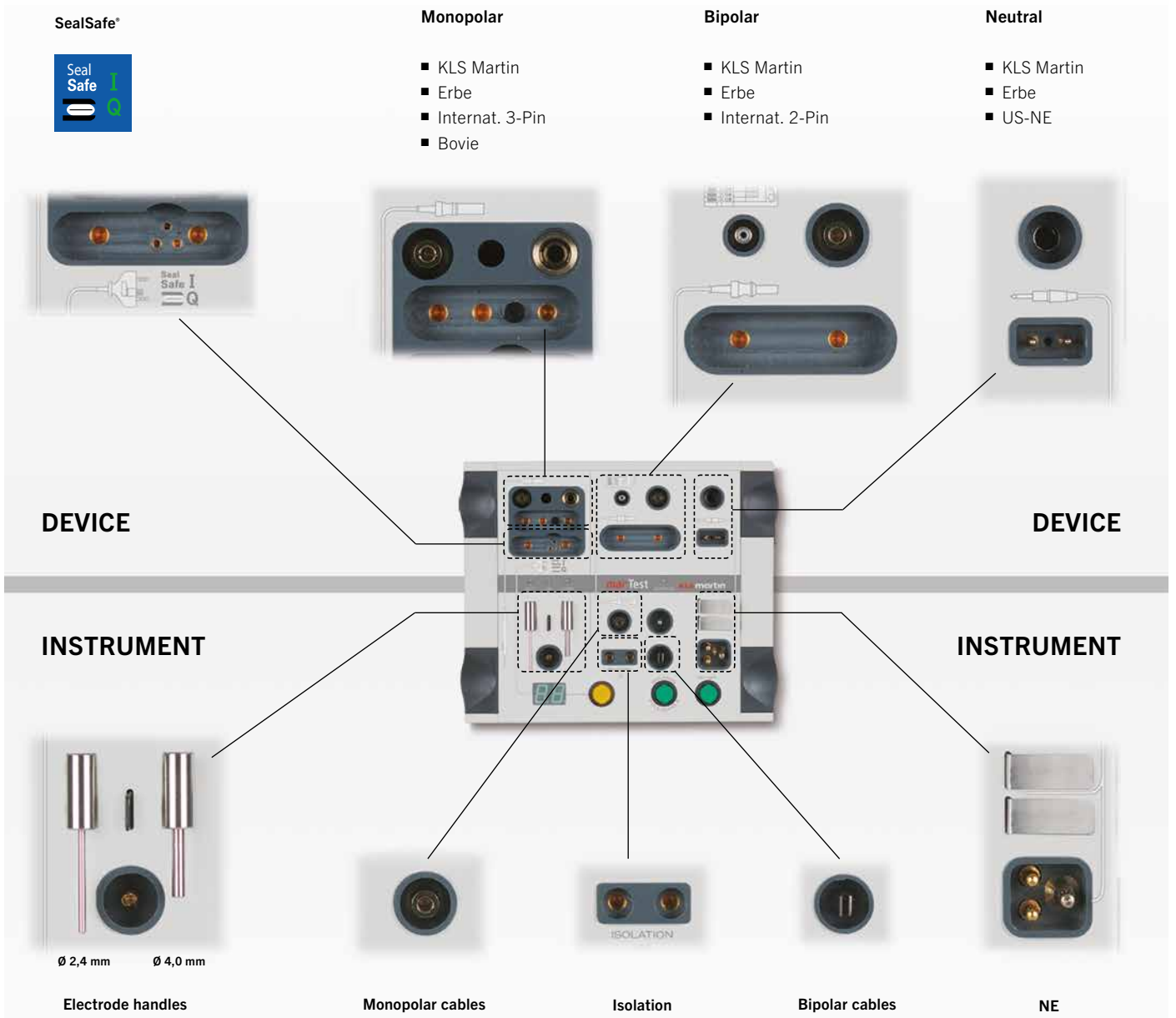

10

Weitere Informationen entnehmen Sie bitte der separaten Broschüre.

For further information please refer to our separate product brochure.

Encontrará informaciones adicionales en el folleto individual.

Vous trouverez des informations supplémentaires dans la brochure.

Per ulteriori informazioni vedasi il prospetto separato.



Geräte zur Funktionsprüfung
Function testers
Aparatos para la comprobación del funcionamiento
Appareils de contrôle de fonctionnement
Apparecchi per prova di funzionamento



80-103-00-04

EPM 4

Leistungsmesskoffer mit Software
Portable power meter, with software
Maleta para medir la potencia con software
Coffre pour mesurer la puissance avec software
Cofano per misurare la potenza con software

08-022-00-19

Bipolarer Prüfadapter: (7+1) für ME 401/411
Bipolar test adapter: (7+1) for ME 401/411
Adaptador de ensayo bipolar: (7+1) para ME 401/411
Adaptateur de contrôle bipolaire: (7+1) pour ME 401/411
Adattatore di prova bipolare (7+1) per ME 401/411

Messkabel für EPM 4

Test cable for EPM 4

Cable de medición para EPM 4

Câble de mesure pour EPM 4

Cavo di misurazione per EPM 4

08-022-00-21

Bipolarer Prüfadapter maXium® (ab HW 02)
Bipolar test adapter for maXium® (from HW 02)
Adaptador de control bipolar para maXium® (a partir del HW 02)
Adaptateur de test bipolaire maXium® (à partir de HW 02)
Adattatore di controllo bipolare maXium® (a partire da HW 02)

08-008-00-06

Messkabel Neutralelektrode KLS Martin
Test cable for KLS Martin neutral electrode
Cable de medición para placa neutra de KLS Martin
Câble de mesure pour électrode neutre KLS Martin
Cavo di misurazione per elettrodo neutro KLS Martin

08-008-00-08

Messkabel monopolar, KLS Martin
Test cable, monopolar, KLS Martin
Cable de medición monopolar, KLS Martin
Câble de mesure monopolaire, KLS Martin
Cavo di misurazione monopolare, KLS Martin

08-008-00-05

Messkabel Fußschalter bipolar
Test cable for bipolar foot switch
Cable de medición para interruptor de pie bipolar
Câble de mesure pour interrupteur à pédale bipolaire
Cavo di misurazione per interruttore a pedale bipolare

08-008-00-03

Messkabel Fußschalter monopolar für Kleingeräte
Test cable for monopolar foot switch for minor HF units
Cable de medición para interruptor de pie monopolar para equipos de AF pequeños
Câble de mesure pour interrupteur à pédale monopolaire pour petits appareils
Cavo di misurazione per interruttore a pedale monopolare per piccoli apparecchi AF

08-008-00-04

Messkabel Fußschalter monopolar für Großgeräte
Test cable for monopolar foot switch for major HF units
Cable de medición para interruptor de pie monopolar para equipos de AF grandes
Câble de mesure pour interrupteur à pédale monopolaire pour grands appareils
Cavo di misurazione per interruttore a pedale monopolare per grandi apparecchi AF

08-008-00-14

Messkabel bipolar KLS Martin / symmetrisch
Test cable, bipolar, KLS Martin / symmetrical
Cable de medición bipolar KLS Martin / simétrico
Câble de mesure bipolaire KLS Martin / symétrique
Cavo di misurazione bipolare KLS Martin / simmetrico

Fußschalter
Foot switches
Interruptores de pie
Interrupteurs à pédale
Interruttori a pedale

11





80-811-50-04

Monopolarer und bipolarer Fußschalter, explosionsgeschützt, AP-geprüft, IP X8, eintauchbar

Monopolar and bipolar foot switch, anti-explosive, AP-tested (anesthetics-proof), IP X8, immersible

Interruptor de pie monopolar y bipolar, antiexplosivo, controlada su aptitud para anestésicos, IP X8, sumergible

Interrupteur à pédale monopolaire et bipolaire, anti-explosif, catégorie AP, IP X8, immergeable

Interruttore a pedale monopolare e bipolare, anti-deflagrante, testato AP, IP X8, immergibile

ME 81 (nur bipolar, bipolar only, sólo bipolar, bipolaire uniquement, solo bipolare)

ME K1

ME K2

ME 82

miniCutter

ME 102 (nur bipolar, bipolar only, sólo bipolar, bipolaire uniquement, solo bipolare)



80-812-10-04

Einpedal-Fußschalter, pneumatisch, 2 m Luftschlauch

Single-pedal foot switch, pneumatic, 2-m air hose

Interruptor de pie de un pedal, neumático, manguera de 2 m

Interrupteur à une pédale, pneumatique, tuyau à air de 2 m

Interruttore monopedale, pneumatico, con tubo flessibile per l'aria da 2 m

MD 62



80-811-04-04

Bipolarer Fußschalter, explosionsgeschützt, AP-geprüft, IP X8, eintauchbar

Bipolar foot switch, anti-explosive, AP-tested (anesthetics-proof), IP X8, immersible

Interruptor de pie, bipolar, antiexplosivo, controlada su aptitud para anestésicos, IP X8, sumergible

Interrupteur à pédale, bipolaire, anti-explosif, catégorie AP, IP X8, immergeable

Interruttore a pedale, bipolare, anti-deflagrante, testato AP, IP X8, immergibile

ME 81 (nur bipolar, bipolar only, sólo bipolar, bipolaire uniquement, solo bipolare)

ME 82

miniCutter (nur bipolar, bipolar only, sólo bipolar, bipolaire uniquement, solo bipolare)

ME 102 (nur bipolar, bipolar only, sólo bipolar, bipolaire uniquement, solo bipolare)

Für alle Fußschalter gilt die Kabellänge 5 m (Ausnahme 80-812-10-04)

Cable length for all foot switches: 5 m (exception 80-812-10-04)

Todos los interruptores de pedal usan un cable de 5 m de longitud (excepción 80-812-10-04)

La longueur de câble de 5 m est valable pour tous les interrupteurs à pédale (exception 80-812-10-04)

Il cavo lungo 5 m è indicato per tutti gli interruttori a pedale (eccezione 80-812-10-04)



80-824-01-04

Doppelpedal-Fußschalter, monopolar,
explosionssgeschützt, AP-geprüft,
IP X8, eintauchbar

ME 81
ME 82
ME 102

Double-pedal foot switch, monopolar,
explosion- and anesthetics-proof (AP-tested),
IP X8, immersible

Interruptor de pie de doble pedal, monopolar,
antiexplosivo, controlada su aptitud para anestésicos,
IP X8, sumergible

Interrupteur à pédale double, monopolaire,
anti-explosif, catégorie AP, IP X8, immergeable

Interruttore a pedale doppio, monopolare,
anti-deflagrante, testato AP, IP X8, immergibile



NON-CE

80-823-02-04

Doppelpedal-Fußschalter, monopolar,
kein AP-Schutz, nicht für OP-Bereich geeignet

ME 81
ME 102

Double-pedal foot switch, monopolar,
not anesthetics-proof (AP), not suitable for use
in operating area

Interruptor de pie de doble pedal, monopolar,
no apto para anestésicos, inapropiado para el
ámbito del quirófano

Interrupteur à pédale double, monopolaire,
pas résistant aux produits anesthésiques,
ne convient pas pour une utilisation en salle
d'opération

Interruttore a pedale doppio, monopolare,
senza protezione AP, non adatto all'uso in
sala operatoria

Für alle Fußschalter gilt die Kabellänge 5 m
Cable length for all foot switches: 5 m
Todos los interruptores de pedal usan un cable de 5 m de longitud
La longueur de câble de 5 m est valable pour tous les interrupteurs à pédale
Il cavo lungo 5 m è indicato per tutti gli interruttori a pedale



80-821-02-04

Doppelpedal-Fußschalter, explosionsgeschützt, AP-geprüft, IP X8, eintauchbar
 Double-pedal foot switch, explosion- and anesthetics-proof (AP-tested), IP X8, immersible
 Interruptor de pie de doble pedal, antiexplosivo, controlada su aptitud para anestésicos, IP X8, sumergible
 Interrupteur à pédale double, anti-explosif, catégorie AP, IP X8, immergeable
 Interruttore a pedale doppio, anti-deflagrante, testato AP, IP X8, immergibile

ME 400/200 (nur monopolar, monopolar only, sólo monopolar, monopolaire uniquement, solo monopolare)
ME 401/411 (nur monopolar, monopolar only, sólo monopolar, monopolaire uniquement, solo monopolare)
ME M1/ME MB 1
ME CD1
ME MB 3
ME MB 2
maXium®



80-830-00-04

Doppelpedalfußschalter, 5 m Kabel, explosions-geschützt, AP-geprüft, IP X8, eintauchbar
 Double-pedal foot switch, 5 m cable, explosion-proof, AP-tested, IP X8, immersible
 Interruptor de pie de doble pedal, cable 5 m, antiexplosivo, controlada su aptitud para anestésicos, IP X8, sumergible
 Interrupteur à pédale double, câble 5 m, anti-explosif, catégorie AP, IP X8, immergeable
 Interruttore a pedale doppio, cavo 5 m, anti-deflagrante, testato AP, IP X8, immergibile

ME 400/200 (nur monopolar, monopolar only, sólo monopolar, monopolaire uniquement, solo monopolare)
ME 401/411 (nur monopolar, monopolar only, sólo monopolar, monopolaire uniquement, solo monopolare)
ME M1/ME MB 1
ME CD1
ME MB 3
ME MB 2
maXium®
maXium® smart C



80-821-03-04

maXium®-SWAP-Mode-Doppelpedal-Fußschalter, explosionsgeschützt, AP-geprüft, IP X8, eintauchbar
 maXium® double-pedal foot switch with SWAP mode, explosion-protected, AP-tested (anesthetics-proof), IP X8, immersible
 Interruptor de pie de doble pedal maXium® con modo SWAP, protegido contra explosiones, controlada su aptitud para anestésicos, IP X8, sumergible
 Interrupteur à double pédale maXium® avec mode SWAP, protégé contre les explosions, testé pour anesthésiants, IP X8, immergeable
 Interruttore a doppio pedale maXium® con modalità SWAP, con protezione antiesplosione, a prova di anestetici, IP X8, immergibile

maXium®

maXium® ab HW 06, Software V3.398
maXium® from HW06 and software V3.398
maXium® a partir del HW06 y software V3.398
maXium® à partir de la version matérielle 06, version logicielle V3.398
maXium® versione HW06 o superiore e software V3.398 o superiore

Für alle Fußschalter gilt die Kabellänge 5 m
 Cable length for all foot switches: 5 m
 Todos los interruptores de pedal usan un cable de 5 m de longitud
 La longueur de câble de 5 m est valable pour tous les interrupteurs à pédale
 Il cavo lungo 5 m è indicato per tutti gli interruttori a pedale



80-830-01-04

SWAP-Mode-Doppelpedalfußschalter, 5 m Kabel, explosionsgeschützt, AP-geprüft, IP X8, eintauchbar

SWAP mode double-pedal foot switch, 5 m cable, explosion-proof, AP-tested, IP X8, immersible

Interruptor de pie de doble pedal con modo SWAP, cable 5 m, antiexplosivo, controlada su aptitud para anestésicos, IP X8, sumergible

Interrupteur à pédale double avec mode SWAP, câble 5 m, anti-explosif, catégorie AP, IP X8, immergeable

Interruttore a pedale doppio con modo SWAP, cavo 5 m, anti-deflagrante, testato AP, IP X8, immergibile

ME 400/200 (nur monopolar, monopolar only, sólo monopolar, monopolaire uniquement, solo monopolare)

ME 401/411 (nur monopolar, monopolar only, sólo monopolar, monopolaire uniquement, solo monopolare)

ME M1/ME MB 1

ME CD1

ME MB 3

ME MB 2

maXium®

maXium® smart C



WIRELESS



80-830-04-04

SWAP-Mode-Doppelpedalfußschalter, **kabellos**, explosionsgeschützt, AP-geprüft, IP X8, eintauchbar

SWAP mode double-pedal foot switch, **wireless**, explosion-proof, AP-tested, IP X8, immersible

Interruptor de pie de doble pedal con modo SWAP, **inalámbrico**, antiexplosivo, controlada su aptitud para anestésicos, IP X8, sumergible

Interrupteur à pédale double avec mode SWAP, **sans fil**, anti-explosif, catégorie AP, IP X8, immergeable

Interruttore a pedale doppio con modo SWAP, **senza fili**, anti-deflagrante, testato AP, IP X8, immergibile

ME 400/200 (nur monopolar, monopolar only, sólo monopolar, monopolaire uniquement, solo monopolare)

ME 401/411 (nur monopolar, monopolar only, sólo monopolar, monopolaire uniquement, solo monopolare)

ME M1/ME MB 1

ME CD1

ME MB 3

ME MB 2

maXium®

maXium® smart C

80-830-05-04

Netzteil für 80-830-04-04 (muss separat bestellt werden)

Power supply unit for 80-830-04-04 (must be ordered separately)

Fuente de alimentación para 80-830-04-04 (se debe encargar por separado)

Bloc d'alimentation pour 80-830-04-04 (doit être commandé séparément)

Alimentatore per 80-830-04-04 (da ordinare separatamente)



80-821-05-04

Doppelpedal-Fußschalter, explosionsgeschützt, AP-geprüft, IP X8, eintauchbar

Double-pedal foot switch, explosion- and anesthetics-proof (AP-tested), IP X8, immersible

Interruptor de pie de doble pedal, antiexplosivo, controlada su aptitud para anestésicos, IP X8, sumergible

Interrupteur à pédale double, anti-explosif, catégorie AP, IP X8, immergeable

Interruttore a pedale doppio, anti-deflagrante, testato AP, IP X8, immergibile

ME 400/200 (nur monopolar, monopolar only, sólo monopolar, monopolaire uniquement, solo monopolare)

ME 401/411 (nur monopolar, monopolar only, sólo monopolar, monopolaire uniquement, solo monopolare)

ME M1/ME MB 1

ME CD1

ME MB 3

ME MB 2

maXium®

maXium® smart C

Für alle Fußschalter gilt die Kabellänge 5 m

Cable length for all foot switches: 5 m

Todos los interruptores de pedal usan un cable de 5 m de longitud

La longueur de câble de 5 m est valable pour tous les interrupteurs à pédale

Il cavo lungo 5 m è indicato per tutti gli interruttori a pedale



80-811-30-04

Doppelpedal-Fußschalter, explosionsgeschützt, AP-geprüft, IP X8, eintauchbar
 Double-pedal foot switch, explosion- and anesthetics-proof (AP-tested), IP X8, immersible
 Interruptor de pie de doble pedal, antiexplosivo, controlada su aptitud para anestésicos, IP X8, sumergible
 Interrupteur à pédale double, anti-explosif, catégorie AP, IP X8, immergeable
 Interruttore a pedale doppio, anti-deflagrante, testato AP, IP X8, immergibile

ME 400/200 (nur monopolar, monopolar only, sólo monopolar, monopolaire uniquement, solo monopolare)
ME 401/411 (nur monopolar, monopolar only, sólo monopolar, monopolaire uniquement, solo monopolare)
ME M1/ME MB 1
ME CD1
ME MB 3
ME MB 2
maXium®
maXium® smart C



80-811-32-04

maXium®-SWAP-Mode-Doppelpedal-Fußschalter Eco, AP-geprüft, IP X8, eintauchbar
 maXium® double-pedal foot switch with SWAP mode Eco, AP-tested (anesthetics-proof), IP X8, immersible
 Interruptor de pie de doble pedal maXium® con modo SWAP Eco, controlada su aptitud para anestésicos, IP X8, sumergible
 Interrupteur à double pédale maXium® avec mode SWAP Eco, testé pour anesthésiants, IP X8, immergeable
 Interruttore a doppio pedale maXium® con modalità SWAP Eco, a prova di anestetici, IP X8, immergibile

maXium®
maXium® ab HW 06, Software V3.398
maXium® from HW06 and software V3.398
maXium® a partir del HW06 y software V3.398
maXium® à partir de la version matérielle 06, version logicielle V3.398
maXium® versione HW06 o superiore e software V3.398 o superiore
maXium® smart C



80-811-04-04

Fußschalter, explosionsgeschützt, AP-geprüft, IP X8, eintauchbar
 Foot switch, explosion- and anesthetics-proof (AP-tested), IP X8, immersible
 Interruptor de pie, antiexplosivo, controlada su aptitud para anestésicos, IP X8, eintauchbar
 Interrupteur à pédale, anti-explosif, catégorie AP, IP X8, immergeable
 Interruttore a pedale, anti-deflagrante, testato AP, IP X8, immergibile

ME 200/400 (nur bipolar, bipolar only, sólo bipolar, bipolaire uniquement, solo bipolare)
ME 401/411 (nur bipolar, bipolar only, sólo bipolar, bipolaire uniquement, solo bipolare)
maXium®

Für alle Fußschalter gilt die Kabellänge 5 m
 Cable length for all foot switches: 5 m
 Todos los interruptores de pedal usan un cable de 5 m de longitud
 La longueur de câble de 5 m est valable pour tous les interrupteurs à pédale
 Il cavo lungo 5 m è indicato per tutti gli interruttori a pedale



80-830-02-04

Einpedalfußschalter, 5 m Kabel, explosionsgeschützt, AP-geprüft, IP X8, eintauchbar

Single-pedal foot switch, 5 m cable, explosion-proof, AP-tested, IP X8, immersible

Interruptor de pie de un pedal, cable 5 m, antiexplosivo, controlada su aptitud para anestésicos, IP X8, sumergible

Interrupteur à une pédale, câble 5 m, anti-explosif, catégorie AP, IP X8, immergeable

Interruttore monopedale, cavo 5 m, anti-deflagrante, testato AP, IP X8, immergibile

ME 200/400 (nur bipolar, bipolar only, sólo bipolar, bipolaire uniquement, solo bipolare)
ME 401/411 (nur bipolar, bipolar only, sólo bipolar, bipolaire uniquement, solo bipolare)
maXium®
maXium® smart C



80-821-04-04

Bipolarer Doppelpedal-Fußschalter, explosionsgeschützt, AP-geprüft, IP X8, immersible

Bipolar double-pedal switch, explosion- and anesthetics-proof (AP-tested), IP X8, eintauchbar

Interruptor de pedal doble, bipolar, antiexplosivo, controlada su aptitud para anestésicos, IP X8, sumergible

Interrupteur à pédale double, bipolaire, anti-explosif, catégorie AP, IP X8, immergeable

Interruttore a doppio pedale, anti-deflagrante, testato AP, IP X8, immergibile

ME 401/411



80-811-50-04

Fußschalter, explosionsgeschützt, AP-geprüft, IP X8, immersible

Foot switch, explosion- and anesthetics-proof (AP-tested), IP X8, eintauchbar

Interruptor de pie, antiexplosivo, controlada su aptitud para anestésicos, IP X8, sumergible

Interrupteur à pédale, anti-explosif, catégorie AP, IP X8, immergeable

Interruttore a pedale, anti-deflagrante, testato AP, IP X8, immergibile

ME 200/400 (nur bipolar, bipolar only, sólo bipolar, bipolaire uniquement, solo bipolare)
ME 401/411 (nur bipolar, bipolar only, sólo bipolar, bipolaire uniquement, solo bipolare)
maXium®
maXium® smart C

Für alle Fußschalter gilt die Kabellänge 5 m
Cable length for all foot switches: 5 m
Todos los interruptores de pedal usan un cable de 5 m de longitud
La longueur de câble de 5 m est valable pour tous les interrupteurs à pédale
Il cavo lungo 5 m è indicato per tutti gli interruttori a pedale

Fußschalter für Großgeräte
Foot switch for major electrosurgery units
Interruptor de pedal para gran aparatos
Interrupteur à pédale pour grands appareils
Interruttore a pedale per apparecchi grandi



80-825-30-04

Bipolarer Doppelpedal-Fußschalter,
explosionssgeschützt, AP-geprüft, IP X8, eintauchbar

Bipolar double-pedal switch, explosion-
and anesthetics-proof (AP-tested), IP X8, immersible

Interruptor de pedal doble, bipolar, antiexplosivo,
controlada su aptitud para anestésicos,
IP X8, sumergible

Interrupteur à pédale double, bipolaire,
anti-explosif, catégorie AP, IP X8, immergeable

Interruttore a doppio pedale, anti-deflagrante,
testato AP, IP X8, immergibile

ME 401/411



1/3

80-797-00-04

Adapter mit gewinkeltem Stecker
Adapter with angled connector
Adaptador con clavija acodada
Adaptateur avec connecteur coudé
Adattatore con connettore angolato

**für Fußschalter
for foot switch
para interruptor de pedal
pour interrupteur à pédale
per interruttore a pedale**

80-821-02-04

80-821-03-04

80-811-30-04

80-811-32-04

80-821-05-04



1/3

80-797-01-04

Adapter mit gewinkeltem Stecker
Adapter with angled connector
Adaptador con clavija acodada
Adaptateur avec connecteur coudé
Adattatore con connettore angolato





**für Fußschalter
for foot switch
para interruptor de pedal
pour interrupteur à pédale
per interruttore a pedale**







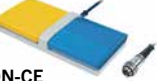

80-811-04-04

80-811-50-04





Für alle Fußschalter gilt die Kabellänge 5 m
Cable length for all foot switches: 5 m
Todos los interruptores de pedal usan un cable de 5 m de longitud
La longueur de câble de 5 m est valable pour tous les interrupteurs à pédale
Il cavo lungo 5 m è indicato per tutti gli interruttori a pedale



Fußschalter Foot switches Interruptores de pie Interrupteurs à pédale Interruttori a pedale	KLS Martin Kleingeräte / Low-end units / Equipos de gama baja / Petits appareils / Apparecchi di piccole dimensioni						
	ME 81	ME 82	miniCutter	ME 102	ME K1	ME K2	MD 62
80-811-50-04 	X nur bipolar, bipolar only, sólo bipolar, bipolaire uniquement, solo bipolare	X	X	X nur bipolar, bipolar only, sólo bipolar, bipolaire uniquement, solo bipolare	X	X	
80-811-04-04 	X nur bipolar, bipolar only, sólo bipolar, bipolaire uniquement, solo bipolare	X	X	X nur bipolar, bipolar only, sólo bipolar, bipolaire uniquement, solo bipolare			
80-824-01-04 	X nur monopolar, monopolar only, sólo monopolar, monopolaire uniquement, solo monopolare	X nur monopolar, monopolar only, sólo monopolar, monopolaire uniquement, solo monopolare		X nur monopolar, monopolar only, sólo monopolar, monopolaire uniquement, solo monopolare			
80-812-10-04 							X
80-823-02-04  NON-CE	X nur monopolar, monopolar only, sólo monopolar, monopolaire uniquement, solo monopolare			X			

Fußschalter Foot switches Interruptores de pie Interrupteurs à pédale Interruttori a pedale	KLS Martin Großgeräte / High-end units / Equipos de gama alta / Grands appareils / Apparecchi di grandi dimension										
	maXium®	maXium® smart C	ME 411	ME 401	ME 400	ME 200	ME MB 1	ME M1	ME CD1	ME MB 2	ME MB 3
80-821-02-04 	X	X	X nur monopolar, monopolar only, sólo monopolar, monopolaire uniquement, solo monopolare	X nur monopolar, monopolar only, sólo monopolar, monopolaire uniquement, solo monopolare	X nur monopolar, monopolar only, sólo monopolar, monopolaire uniquement, solo monopolare	X nur monopolar, monopolar only, sólo monopolar, monopolaire uniquement, solo monopolare	X	X	X	X	X
80-821-03-04 	X nur ab only from sólo a partir de uniquement solo HW. 06, SW V3.398	X									
80-811-32-04 	X nur ab only from sólo a partir de uniquement solo HW. 06, SW V3.398	X									
80-821-05-04 	X	X	X nur monopolar, monopolar only, sólo monopolar, monopolaire uniquement, solo monopolare	X nur monopolar, monopolar only, sólo monopolar, monopolaire uniquement, solo monopolare	X nur monopolar, monopolar only, sólo monopolar, monopolaire uniquement, solo monopolare	X nur monopolar, monopolar only, sólo monopolar, monopolaire uniquement, solo monopolare	X	X	X	X	X
80-821-04-04 			X nur bipolar, bipolar only, sólo bipolar, bipolaire uniquement, solo bipolare	X							
80-811-30-04 	X	X	X nur monopolar, monopolar only, sólo monopolar, monopolaire uniquement, solo monopolare	X nur monopolar, monopolar only, sólo monopolar, monopolaire uniquement, solo monopolare	X nur monopolar, monopolar only, sólo monopolar, monopolaire uniquement, solo monopolare	X nur monopolar, monopolar only, sólo monopolar, monopolaire uniquement, solo monopolare	X	X	X	X	X
80-825-30-04 			X nur bipolar, bipolar only, sólo bipolar, bipolaire uniquement, solo bipolare	X							
80-811-04-04 	X	X	X nur bipolar, bipolar only, sólo bipolar, bipolaire uniquement, solo bipolare	X nur bipolar, bipolar only, sólo bipolar, bipolaire uniquement, solo bipolare	X nur bipolar, bipolar only, sólo bipolar, bipolaire uniquement, solo bipolare	X nur bipolar, bipolar only, sólo bipolar, bipolaire uniquement, solo bipolare					
80-811-50-04 	X	X	X nur bipolar, bipolar only, sólo bipolar, bipolaire uniquement, solo bipolare	X nur bipolar, bipolar only, sólo bipolar, bipolaire uniquement, solo bipolare	X nur bipolar, bipolar only, sólo bipolar, bipolaire uniquement, solo bipolare	X nur bipolar, bipolar only, sólo bipolar, bipolaire uniquement, solo bipolare					



Fußschalter Foot switches Interruptores de pie Interrupteurs à pédale Interruttori a pedale	KLS Martin Großgeräte / High-end units / Equipos de gama alta / Grands appareils / Apparecchi di grandi dimension										
	maXium®	maXium® smart C	ME 411	ME 401	ME 400	ME 200	ME MB 1	ME M1	ME CD1	ME MB 2	ME MB 3
80-830-00-04 	X	X	X nur monopolar, monopolar only, sólo monopolar, monopolaire uniquement, solo monopolare	X nur monopolar, monopolar only, sólo monopolar, monopolaire uniquement, solo monopolare	X nur monopolar, monopolar only, sólo monopolar, monopolaire uniquement, solo monopolare	X nur monopolar, monopolar only, sólo monopolar, monopolaire uniquement, solo monopolare	X	X	X	X	X
80-830-01-04 	X nur ab only from sólo a partir de uniquement solo HW. 06, SW V3.398										
80-830-04-04 + 80-830-05-04 	X nur ab only from sólo a partir de uniquement solo HW. 06, SW V3.398										
80-830-02-04 	X	X	X	X	X	X					

12

Netzkabel
Mains cables
Cables de conexión a la red
Câbles d'alimentation réseau
Cavi d'alimentazione dalla rete



Netzkabel
 Mains cables
 Cables de conexión a la red
 Câbles d'alimentation réseau
 Cavi d'alimentazione dalla rete



1/3

08-024-00-23

3 m/10 ft.

Netzkabel, z.B. für Deutschland, Frankreich, Österreich, Skandinavien, Korea

Mains cables, for ex. for Germany, France, Austria, Scandinavia, Korea

Cables de conexión a la red, p. ej. para Alemania, Francia, Austria, Escandinavia, Corea

Câbles d'alimentation réseau, par ex. pour l'Allemagne, France, Autriche, Scandinavie, la Corée

Cavi d'alimentazione, p. es. per la Germania, Francia, Austria, Scandinavia, Corea



1/3

08-025-00-23

5 m/16,4 ft.

Netzkabel, z.B. für Deutschland, Frankreich, Österreich, Skandinavien, Korea

Mains cables, for ex. for Germany, France, Austria, Scandinavia, Korea

Cables de conexión a la red, p. ej. para Alemania, Francia, Austria, Escandinavia, Corea

Câbles d'alimentation réseau, par ex. pour l'Allemagne, France, Autriche, Scandinavie, la Corée

Cavi d'alimentazione, p. es. per la Germania, Francia, Austria, Scandinavia, Corea



1/3

08-024-00-30

2,5 m/8,2 ft.

Netzkabel für Italien

Mains cables for Italy

Cables de conexión a la red para Italia

Câbles d'alimentation réseau pour l'Italie

Cavi d'alimentazione per Italia



1/3

08-024-00-40

1,8 m/6 ft.

Netzkabel für Grossbritannien, Irland, Vereinigte Arabische Emirate

Mains cables for United Kingdom, Ireland, United Arab Emirates

Cables de red para el Reino Unido, Irlanda, Emiratos Árabes Unidos.

Câbles d'alimentation réseau pour la Grande-Bretagne, l'Irlande, les Emirats Arabes Unis

Cavi di rete per Gran Bretagna, Irlanda, Emirati Arabi Uniti



1/3

08-024-00-83

5 m/16,4 ft.

Netzkabel für Grossbritannien, Irland, Vereinigte Arabische Emirate

Mains cables for United Kingdom, Ireland, United Arab Emirates

Cables de red para el Reino Unido, Irlanda, Emiratos Árabes Unidos.

Câbles d'alimentation réseau pour la Grande-Bretagne, l'Irlande, les Emirats Arabes Unis

Cavi di rete per Gran Bretagna, Irlanda, Emirati Arabi Uniti



1/3

08-024-00-31

2,5 m/8,2 ft.

Netzkabel für Japan

Mains cables for Japan

Cables de conexión a la red para Japón

Câbles d'alimentation réseau pour Japon

Cavi d'alimentazione per Giappone



1/3

08-024-00-28

1,8 m/6 ft.

Netzkabel, z.B. für Taiwan, USA, Kanada

Mains cables, for ex. for Taiwan, USA, Canada

Cables de conexión a la red, p. ej. para Taiwan, USA, Canadá

Câbles d'alimentation réseau, par ex. pour Taiwan, USA, Canada

Cavi d'alimentazione, p. es. per Taiwan, USA, Canada



1/3

08-024-00-29

2 m/6,5 ft.

Netzkabel, z.B. für Taiwan, USA, Kanada

Mains cables, for ex. for Taiwan, USA, Canada

Cables de conexión a la red, p. ej. para Taiwan, USA, Canadá

Câbles d'alimentation réseau, par ex. pour Taiwan, USA, Canada

Cavi d'alimentazione, p. es. per Taiwan, USA, Canada



1/3

08-024-00-41

2,5 m/8,2 ft.

Netzkabel für China

Mains cables for China

Cables de conexión a la red para China

Câbles d'alimentation réseau pour Chine

Cavi d'alimentazione per Cina

Fahrgestelle
Trolleys
Soportes móviles
Chariots
Carrelli

13



Fahrgestelle/maXium® smart Cart
 Trolleys/maXium® smart Cart
 Soportes móviles/maXium® smart Cart
 Supports roulants (chariots)/maXium® smart Cart
 Carrelli/maXium® smart Cart



Konfiguration mit maXium®,
 maXium® beamer und maXium® smart Vac
 Configuration with maXium®, maXium® beamer
 and maXium® smart Vac
 Configuración con maXium®, maXium® beamer
 y maXium® smart Vac
 Configuration avec maXium®, maXium® beamer
 et maXium® smart Vac
 Configurazione con maXium®, maXium® beamer
 e maXium® smart Vac

80-048-00-04 maXium® smart Cart – geeignet für alle KLS-Martin-Großgeräte	80-048-00-04 maXium® smart Cart – suitable for all major KLS Martin units	80-048-00-04 maXium® smart Cart – adecuado para todos los aparatos de gran tamaño de KLS Martin
Abmessungen (B x H x T): 755 x 1080 x 655 mm	Dimensions (W x H x D): 755 x 1080 x 655 mm	Dimensiones (An + Al + P): 755 x 1080 x 655 mm
4 Doppelrollen mit 2 Bremsen	4 dual castors with 2 brakes	4 ruedas dobles con 2 frenos
Ablagekorb	Storage basket	Bandeja
Potenzialausgleichsanschlüsse (POAG)	Equipotential bonding connections (POAG)	Conexiones equipotenciales (POAG)
Fußschalterhalterung	Foot switch holder	Soporte para pedal
Netzkabel 5 m	Mains cable 5 m	Cable de red 5 m
Netzabgänge	Mains power outputs	Salidas de red
Gewicht 40 Kg	Weight 40 kg	Peso 40 kg
Geräteaufnahme (muss zwingend notwendig mitbestellt werden)	Device holder (must be included in the order)	Soporte de aparato (es imprescindible encargarlo)
80-048-03-04 Geräteaufnahme für maXium® smart Line	Device holder for maXium® smart Line	Soporte de aparato para maXium® smart Line
80-048-04-04 Aufnahme für maXium® White Edition	Holder for maXium® White Edition	Soporte para maXium® White Edition
Optionales Zubehör:	Optional accessories:	Accesorios opcionales:
80-048-01-04 Normschiene	Standard rail	Riel normalizado
80-048-02-04 Trenntransformator	Separating transformer	Transformador de aislamiento
80-048-05-04 Gasflaschenhalter	Gas bottle holder	Soporte para cilindros de gas
80-048-06-04 Befestigungssatz für maXium® smart Vac®	Mounting kit for maXium® smart Vac®	Kit de fijación para maXium® smart Vac®

Die abgebildeten Geräte sind im Lieferumfang nicht enthalten!
 The HF units shown are not included in the scope of supply!
 ¡Los equipos representados en las imágenes no forman parte del suministro!
 Les appareils présentés ici ne font pas partie de la livraison !
 Gli apparecchi raffigurati non fanno parte della fornitura!



Konfiguration mit maXium® smart C,
maXium® smart Beam und maXium® smart Vac
Configuration with maXium® smart C,
maXium® smart Beam and maXium® smart Vac
Configuración con maXium® smart C,
maXium® smart Beam y maXium® smart Vac
Configuration avec maXium® smart C,
maXium® smart Beam et maXium® smart Vac
Configurazione con maXium® smart C,
maXium® smart Beam e maXium® smart Vac



80-260-50-04

4 m/13 ft.

Potenzialausgleichskabel
Potential equalization cable
Cable de conexión equipotencial
Câble de compensation de potentiel
Cavo per collegamento equipotenziale

<p>80-048-00-04 maXium® smart Cart – pour tous les grands appareils KLS Martin</p> <p>Dimensions (l x H x p) : 755 x 1080 x 655 mm 4 roulettes doubles avec 2 freins Panier de rangement Raccords d'équipotentialité (POAG) Support d'interrupteur à pédale Câble secteur 5 m Prises d'alimentation Poids 40 kg</p>	<p>80-048-00-04 maXium® smart Cart – indicato per tutti i grandi apparecchi KLS Martin</p> <p>Dimensioni (L x A x P): 755 x 1080 x 655 mm 4 ruote doppie con 2 freni Cestello portaoggetti Attacchi per collegamento equipotenziale (POAG) Supporto interruttore a pedale Cavo di rete 5 m Uscite di rete Peso 40 kg</p>
<p>Logement (doit impérativement être commandé)</p> <p>80-048-03-04 Logement pour maXium® smart Line 80-048-04-04 Logement pour maXium® White Edition</p>	<p>Supporto apparecchio (da ordinarsi obbligatoriamente assieme all'apparecchio)</p> <p>Supporto apparecchio per maXium® smart Line Supporto per maXium® White Edition</p>
<p>Accessoires facultatifs :</p> <p>80-048-01-04 Rail standard 80-048-02-04 Transformateur d'isolement 80-048-05-04 Porte-bouteille 80-048-06-04 Set de fixation pour maXium® smart Vac®</p>	<p>Accessori opzionali:</p> <p>Guida normata Trasformatore di isolamento Supporto bombola gas Set di fissaggio per maXium® smart Vac®</p>

Die abgebildeten Geräte sind im Lieferumfang nicht enthalten!
The HF units shown are not included in the scope of supply!
¡Los equipos representados en las imágenes no forman parte del suministro!
Les appareils présentés ici ne font pas partie de la livraison !
Gli apparecchi raffigurati non fanno parte della fornitura!

maXium® smart Cart mit verschiedenen Komponenten
maXium® smart Cart with various components
maXium® smart Cart con diferentes componentes
maXium® smart Cart avec différents composants
maXium® smart Cart con diversi componenti

Frontansicht maXium® smart Cart (Art.-Nr. 80-048-00-04)
Front view of maXium® smart Cart (item no. 80-048-00-04)
Vista frontal del maXium® smart Cart (n.º ref. 80-048-00-04)
Vue de face de maXium® smart Cart (réf. 80-048-00-04)
Immagine frontale di maXium® smart Cart (codice art. 80-048-00-04)



Netzkabel, 5 m, z.B. für Deutschland,
Frankreich, Österreich, Skandinavien
Mains cables, 5 m, for ex. for Germany,
France, Austria, Scandinavia
Cables de conexión a la red, 5 m, p. ej.
para Alemania, Francia, Austria, Escandinavia
Câbles d'alimentation réseau, 5 m, par ex.
pour l'Allemagne, France, Autriche, Scandinavie
Cavi d'alimentazione, 5 m, p. es. per la
Germania, Francia, Austria, Scandinavia

Gasflaschenhalter für 2 Gasflaschen
Gas bottle holder for 2 gas bottles
Soporte para cilindros de gas
para 2 cilindros de gas
Porte-bouteille de gaz
pour 2 porte-bouteilles de gaz
Supporto bombola gas
per 2 bombole gas

Doppellenk-Rolle mit Bremse (2 Stück)
Dual castor with brake (2 items)
Rodillo doble giratorio con freno (2 unidades)
Roulette double avec frein de blocage (2 pièces)
Rotelle orientabili doppie con freno (2 pezzi)

Die abgebildeten Geräte sind im Lieferumfang nicht enthalten!
The HF units shown are not included in the scope of supply!
¡Los equipos representados en las imágenes no forman parte del suministro!
Les appareils présentés ici ne font pas partie de la livraison !
Gli apparecchi raffigurati non fanno parte della fornitura!



Rückansicht maXium® smart Cart (Art.-Nr. 80-048-00-04)
Rear view of maXium® smart Cart (item no. 80-048-00-04)
Vista posterior del maXium® smart Cart (n.º ref. 80-048-00-04)
Vue de derrière de maXium® smart Cart (réf. 80-048-00-04)
Immagine posteriore di maXium® smart Cart (codice art. 80-048-00-04)

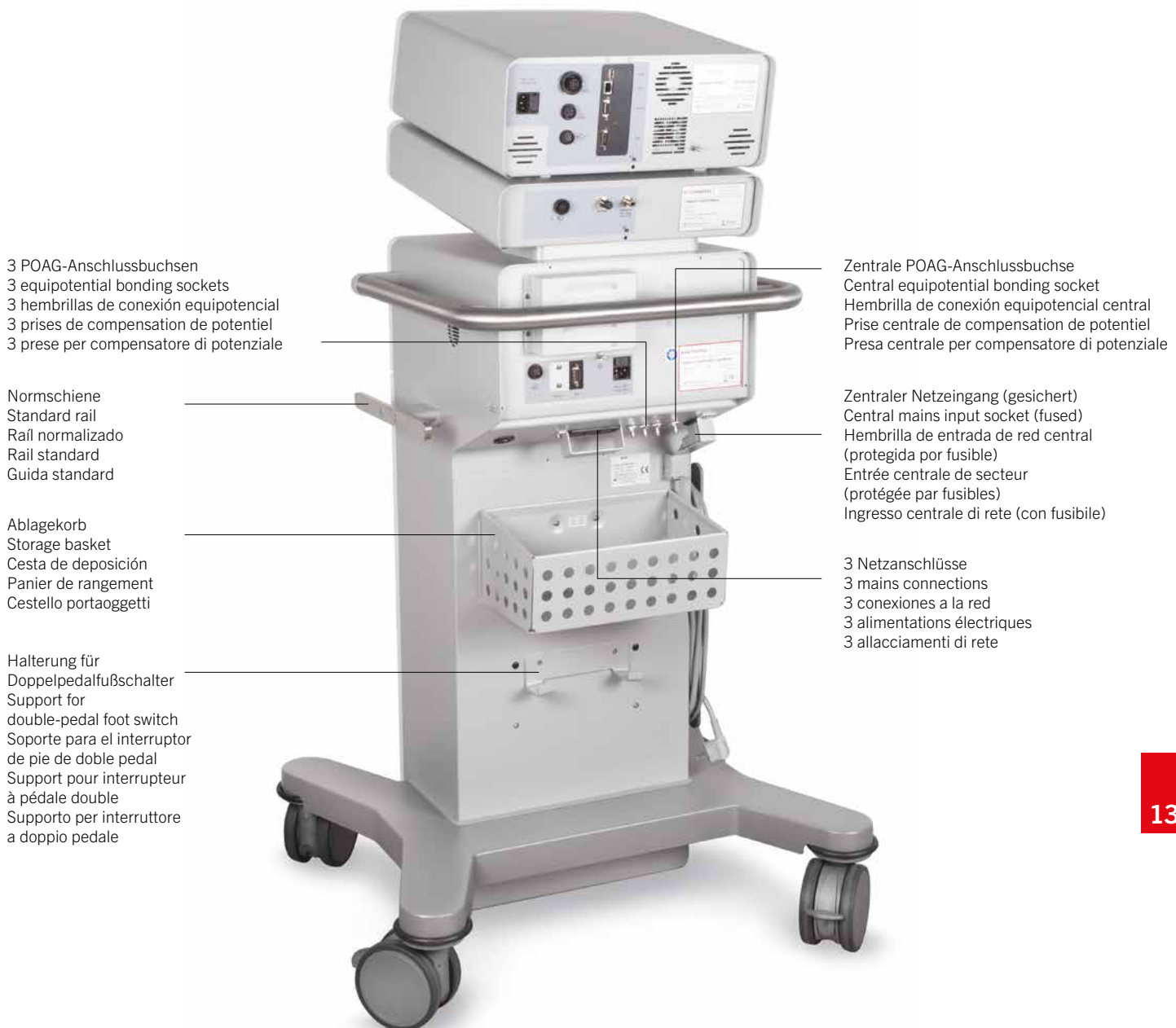

HF-Fahrwagen
 HF trolleys
 Carros portaequipos de AF
 Chariots HF
 Carrelli AF



80-070-00-04

HF-Fahrwagen
 HF trolley
 Carro portaequipos de AF
 Chariot HF
 Carrello AF

für maXium® smart C bitte zusätzlich Halterung 80-070-06-04 bestellen
 for maXium® smart C please also order holder 80-070-06-04
 encargar para maXium® smart C adicionalmente el soporte 80-070-06-04
 pour maXium® smart C, prière de commander en supplément le support 80-070-06-04
 per maXium® smart C si prega di ordinare anche il supporto 80-070-06-04

	Befestigungssatz	Fastening kit	Juego de sujeción	Set d'accrochage	Set di fissaggio
80-070-02-04	für ME 102	for ME 102	para ME 102	pour ME 102	per ME 102
80-070-03-04	für miniCutter	for miniCutter	para miniCutter	pour miniCutter	per miniCutter
80-070-04-04	für MD 62	for MD 62	para MD 62	pour MD 62	per MD 62
80-070-06-04	für maXium® smart Line	for maXium® smart Line	para maXium® smart Line	pour maXium® smart Line	per maXium® smart Line

- Geeignet für alle KLS-Martin-HF-Großgeräte, z.B. ME MB 1, ME MB 3, maXium®, maXium® smart C
- Farbe: Eloxal-Silber
- Elektrisch leitfähige Doppelrollen (ESD) mit 65 mm Durchmesser
- Ablagefach
- Optionaler Drahtkorb zur Ablage von Zubehörkomponenten (08-168-00-20)
- Kabelhalterung für das Netzkabel
- Abmessungen: 400 x 430 x 900 mm (B x H x T)
- Gewicht: 12 Kg

- Pour tous les grands appareils HF KLS Martin, par ex. ME MB 1, ME MB 3 maXium®, maXium® smart C
- Couleur: anodisation argentée
- Roues doubles conductrices (ESD) de diamètre 65 mm
- Compartiment de rangement
- Panier métallique en option pour le rangement des accessoires (08-168-00-20)
- Attache pour le câble de réseau
- Dimensions: 400 x 430 x 900 mm (l x h x p)
- Poids: 12 Kg

- Suitable for all major KLS Martin HF units. e.g. ME MB 1, ME MB 3, maXium®, maXium® smart C
- Color: silver-anodized
- Electrically conductive dual castors (ESD), diameter 65 mm
- Storage compartment
- Optional wire basket for storing accessories (08-168-00-20)
- Power cord holder
- Dimensions: 400 x 430 x 900 mm (W x H x D)
- Weight: 12 Kg

- Adatto a tutti gli apparecchi grandi AF KLS Martin, p. es. ME MB 1, ME MB 3 maXium®, maXium® smart C
- Colore: anodizzazione argentea
- Rotelle doppie (ESD) a conduzione elettrica con diametro di 65 mm
- Compartimento
- Optional cestino in metallo per poggiare accessori (08-168-00-20)
- Supporto cavo per cavo di alimentazione
- Dimensioni: 400 x 430 x 900 mm (L x A x P)
- Peso: 12 Kg

- Adecuado para todos los equipos de AF KLS Martin de gran tamaño, p. ej. ME MB 1, ME MB 3, maXium®, maXium® smart C
- Color: anodizado plateado
- Rodillos dobles electroconductores (DES) con 65 mm de diámetro
- Cajón de deposición
- Cesta de alambre opcional para la deposición de componentes accesorios (08-168-00-20)
- Sujeción para el cable de red
- Dimensiones: 400 x 430 x 900 mm (An x A x P)
- Peso: 12 Kg



Optionales Zubehör für HF-Fahrgewagen Art.-Nr. 80-070-00-04
Optional accessories for HF trolley no. 80-070-00-04
Accesorio opcional para el carro de AF, n.º ref. 80-070-00-04
Accessoires en option pour chariot HF, réf. 80-070-00-04
Accessori opzionali per carrello AF, codice art. 80-070-00-04



80-070-01-04

Halterung für Argon-Gasflasche
Support for argon gas cylinder
Soporte para la sujeción de la bombona de gas argón
Support pour bouteille de gaz d'argon
Supporto per bombola di gas argon

08-156-00-11

Rolle, feststellbar, für HF-Fahrgewagen (1 Stück)
Castor, lockable, for HF trolley (1 piece)
Rodillo, bloqueable, para carro de AF (1 pieza)
Roulette, blocable, pour chariot HF (1 pièce)
Rotella, bloccabile, per carrello AF (1 pezzo)

80-070-05-04

Rollensatz für HF-Fahrgewagen 80-070-00-04
Ø 100 mm (2 Stück feststellbar, 2 Stück ungebremst)

Set of castors for HF trolley 80-070-00-04,
Ø 100 mm (2 lockable, 2 without brake)

Juego de ruedas para el carro portaequipos 80-070-00-04,
Ø 100 mm (2 unidades bloqueables, 2 unidades sin freno)

Lot de roulettes pour chariot HF 80-070-00-04
Ø 100 mm (2 roulettes blocables, 2 roulettes non freinées)

Set di rotelle per carrello AF 80-070-00-04, Ø 100 mm
(2 rotelle fissabili, 2 rotelle senza freno)

Zubehörsätze
Accessory sets
Juegos de accesorios
Jeux d'accessoires
Serie di accessori

14

Zubehörsätze für Großgeräte

Accessory sets for major electrosurgical units

Juegos de accesorios para gran aparatos

Jeux d'accessoires pour grands appareils

Serie di accessori per apparecchi grandi

80-140-00-04	Großer Zubehörsatz monopolar, Handaktivierung für ME MB 3/ ME MB 1/ maxium („m“-Version), bestehend aus:	Accessory set monopolar, large for hand switch operation ME MB 3/ ME MB 1/ maXium® ("m"-version), consisting of:	Juego de accesorios monopolar, grande con interruptor digital ME MB 3/ ME MB 1/ maXium® (versión "m"), compuesto de:
80-217-13-04	1 smartPen Elektroden-Handgriff mit zwei Tasten für 4-mm-Elektroden, mit KLS Martin-Stecker	- smartPen Elektroden-Handgriff mit zwei Tasten für 4-mm-Elektroden, mit KLS Martin-Stecker	- smartPen Elektroden-Handgriff mit zwei Tasten für 4-mm-Elektroden, mit KLS Martin-Stecker
80-342-03-04	1 Gummi-Neutralelektrode 15 x 26 cm, 4 m Kabel	- Rubber neutral electrode, 15 x 26 cm, with connection cable, 4 m	- Placa neutra de goma, 15 x 26 cm, cable de conexión de 4 m
80-371-00-04	2 Gummibinden, gelocht, 100 cm	- Rubber bands, with holes, 100 cm	- Cintas de goma, perforadas, 100 cm
80-371-01-04	2 Knöpfe für Gummibinde	- Buttons for rubber band	- Botones para la cinta de goma
80-416-00-01	1 Elektroden-Ständer für 16 Elektroden	- Electrode box for 16 electrodes	- Caja para 16 electrodos
80-505-00-04	1 Reinigungspad für Elektroden, steril verpackt, VE = 100 Stck.	- Cleaning pad for electrodes, sterile packed, SU = 100/pack	- Almohadilla de limpieza para electrodos, embalado estéril, UV = 100 piezas
80-510-04-04	1 Lanzettelektrode, gerade	- Lancet electrode, straight	- Electrodo de lanceta, recto
80-511-04-04	1 Lanzettelektrode, abgewinkelt	- Lancet electrode, angled	- Electrodo de lanceta, acodado
80-515-04-04	1 Messerelektrode	- Knife electrode	- Electrodo de cuchillo
80-520-04-04	1 Nadelelektrode	- Needle electrode	- Electrodo de aguja
80-540-04-04	1 Drahtschlingenelektrode, Ø 5 mm	- Wire loop electrode, Ø 5 mm	- Electrodo de asa de alambre, Ø 5 mm
80-542-04-04	1 Drahtschlingenelektrode, Ø 10 mm	- Wire loop electrode, Ø 10 mm	- Electrodo de asa de alambre, Ø 10 mm
80-550-04-04	1 Bandschlingenelektrode, Ø 10 mm	- Ribbon loop electrode, Ø 10 mm	- Electrodo de asa de cinta, Ø 10 mm
80-552-04-04	1 Bandschlingenelektrode, Ø 15 mm	- Ribbon loop electrode, Ø 15 mm	- Electrodo de asa de cinta, Ø 15 mm
80-560-04-04	1 Kugelelektrode, Ø 2 mm	- Ball electrode, Ø 2 mm	- Electrodo de bola, Ø 2 mm
80-562-04-04	1 Kugelelektrode, Ø 4 mm	- Ball electrode, Ø 4 mm	- Electrodo de bola, Ø 4 mm
80-563-04-04	1 Kugelelektrode, Ø 5 mm	- Ball electrode, Ø 5 mm	- Electrodo de bola, Ø 5 mm
80-570-04-04	1 Plattenelektrode, 8 x 10 mm	- Plate electrode, 8 x 10 mm	- Electrodo de placa, 8 x 10 mm

80-150-00-04	Zubehörsatz bipolar für KLS Martin maxium („m“-Version), ME MB 3/ME MB 1*	Set bipolar accessories for KLS Martin maXium® ("m"-Version), ME MB 3/ME MB 1*	Juego de accesorios bipolar para KLS Martin maXium® (versión "m"), ME MB 3/ME MB 1*
80-287-53-04	1 Anschlusskabel für bipolare Pinzetten	- Connection cable for bipolar forceps	- Cable de conexión para pinzas bipolares
80-924-16-04	1 Bipolare Pinzette, gerade, stumpf, 16 cm/6 1/4"	- Bipolar forceps, straight, blunt, 16 cm/6 1/4"	- Pinza bipolar, recta, roma, 16 cm/6 1/4"
80-945-20-04	1 Bipolare Pinzette, bajonettförmig, stumpf, 20 cm/8"	- Bipolar forceps, bayonet-shaped, blunt, 20 cm/8"	- Pinza bipolar, en forma bayoneta, roma, 20 cm/8"
80-925-16-04	1 Bipolare Pinzette, abgewinkelt, stumpf, 16 cm/6 1/4"	- Bipolar forceps, angled, blunt, 16 cm/6 1/4"	- Pinza bipolar, acodada, roma, 16 cm/6 1/4"

Zubehörsätze für Großgeräte
 Accessory sets for major electrosurgery units
 Juegos de accesorios para gran aparatos
 Jeux d'accessoires pour grands appareils
 Serie di accessori per apparecchi grandi

80-140-00-04		Großer Zubehörsatz monopolar, Handaktivierung für ME MB 3/ ME MB 1/ maXium® m, bestehend aus:	Accessory set monopolar, large for hand switch operation ME MB 3/ ME MB 1/ maXium® m, consisting of:	Juego de accesorios monopolar, grande con interruptor digital ME MB 3/ ME MB 1/ maXium® m, compuesto de:
80-217-13-04	1	smartPen Elektroden-Handgriff mit zwei Tasten für 4-mm-Elektroden, mit KLS Martin-Stecker	smartPen Electrode handle with two pushbuttons for 4-mm electrodes, with KLS Martin plug	Mango porta-electrodos smartPen con dos teclas, para electrodos de 4 mm, con clavija de KLS Martin
80-342-03-04	1	Gummi-Neutralelektrode 15 x 26 cm, 4 m Kabel	Rubber neutral electrode, 15 x 26 cm, with connection cable, 4 m	Placa neutra de goma, 15 x 26 cm, cable de conexión de 4 m
80-371-00-04	2	Gummibinden, gelocht, 100 cm	Rubber bands, with holes, 100 cm	Cintas de goma, perforadas, 100 cm
80-371-01-04	2	Knöpfe für Gummibinde	Buttons for rubber band	Botones para la cinta de goma
80-416-00-01	1	Elektroden-Ständer für 16 Elektroden	Electrode box for 16 electrodes	Caja para 16 electrodos
80-505-00-04	1	Reinigungspad für Elektroden, steril verpackt, VE = 100 Stck.	Cleaning pad for electrodes, sterile packed, SU = 100/pack	Almohadilla de limpieza para electrodos, embalado estéril, UV = 100 piezas
80-510-04-04	1	Lanzettelektrode, gerade	Lancet electrode, straight	Electrodo de lanceta, recto
80-511-04-04	1	Lanzettelektrode, abgewinkelt	Lancet electrode, angled	Electrodo de lanceta, acodado
80-515-04-04	1	Messerelektrode	Knife electrode	Electrodo de cuchillo
80-520-04-04	1	Nadelelektrode	Needle electrode	Electrodo de aguja
80-540-04-04	1	Drahtschlingenelektrode, Ø 5 mm	Wire loop electrode, Ø 5 mm	Electrodo de asa de alambre, Ø 5 mm
80-542-04-04	1	Drahtschlingenelektrode, Ø 10 mm	Wire loop electrode, Ø 10 mm	Electrodo de asa de alambre, Ø 10 mm
80-550-04-04	1	Bandschlingenelektrode, Ø 10 mm	Ribbon loop electrode, Ø 10 mm	Electrodo de asa de cinta, Ø 10 mm
80-552-04-04	1	Bandschlingenelektrode, Ø 15 mm	Ribbon loop electrode, Ø 15 mm	Electrodo de asa de cinta, Ø 15 mm
80-560-04-04	1	Kugelelektrode, Ø 2 mm	Ball electrode, Ø 2 mm	Electrodo de bola, Ø 2 mm
80-562-04-04	1	Kugelelektrode, Ø 4 mm	Ball electrode, Ø 4 mm	Electrodo de bola, Ø 4 mm
80-563-04-04	1	Kugelelektrode, Ø 5 mm	Ball electrode, Ø 5 mm	Electrodo de bola, Ø 5 mm
80-570-04-04	1	Plattenelektrode, 8 x 10 mm	Plate electrode, 8 x 10 mm	Electrodo de placa, 8 x 10 mm

80-150-00-04		Zubehörsatz bipolar für KLS Martin maXium® m, ME MB 3/ME MB 1*	Set bipolar accessories for KLS Martin maXium® m, ME MB 3/ME MB 1*	Juego de accesorios bipolar para KLS Martin maXium® m, ME MB 3/ME MB 1*
80-287-53-04	1	Anschlusskabel für bipolare Pinzetten	Connection cable for bipolar forceps	Cable de conexión para pinzas bipolares
80-924-16-04	1	Bipolare Pinzette, gerade, stumpf, 16 cm/6 1/4"	Bipolar forceps, straight, blunt, 16 cm/6 1/4"	Pinza bipolar, recta, roma, 16 cm/6 1/4"
80-945-20-04	1	Bipolare Pinzette, bajonettförmig, stumpf, 20 cm/8"	Bipolar forceps, bayonet-shaped, blunt, 20 cm/8"	Pinza bipolar, en forma bayoneta, roma, 20 cm/8"
80-925-16-04	1	Bipolare Pinzette, abgewinkelt, stumpf, 16 cm/6 1/4"	Bipolar forceps, angled, blunt, 16 cm/6 1/4"	Pinza bipolar, acodada, roma, 16 cm/6 1/4"
80-925-20-04	1	Bipolare Pinzette, abgewinkelt, stumpf, 20 cm/8"	Bipolar forceps, angled, blunt, 20 cm/8"	Pinza bipolar, acodada, roma, 20 cm/8"
80-924-20-04	1	Bipolare Pinzette, gerade, stumpf, 20 cm/8"	Bipolar forceps, straight, blunt, 20 cm/8"	Pinza bipolar, recta, roma, 20 cm/8"

* Nur in Verbindung mit Fußschalter

* Only in connection with foot switch

* Solamente en conexión con interruptor de pie

80-140-00-04		Grand lot d'accessoires monopolaire pour commande digitale ME MB 3/ ME MB 1/ maXium® m, composé de:	Serie grande di accessori monopolare standard per attivazione a mano ME MB 3/ ME MB 1/ maXium® m, composta di:
80-217-13-04	1	Manche porte-électrode smartPen avec interrupteur digital double, pour electrodes de 4 mm, avec fiche de KLS Martin	Manico portaelettrodi smartPen con due tasti, per elettrodi da 4 mm, con spina da KLS Martin
80-342-03-04	1	Electrode neutre en caoutchouc, 15 x 26 cm, avec câble de raccordement de 4 m	Elettrodo neutro di gomma, 15 x 26 cm, cavo di connessione di 4 m
80-371-00-04	2	Bandes caoutchouc, perforées, 100 cm	Nastri di gomma, perforati, 100 cm
80-371-01-04	2	Boutons pour bande caoutchouc	Bottoni per nastro di gomma
80-416-00-01	1	Boîte pour 16 électrodes	Supporto per 16 elettrodi in scatola
80-505-00-04	1	Tampon de nettoyage pour électrodes, emballage stérile, UC = 100 pièces	Tampone di pulizia per elettrodi, imballaggio sterile, UV = 100 pezzi
80-510-04-04	1	Electrode lancette, droite	Elettrodo a lancetta, retto
80-511-04-04	1	Electrode lancette, coudée	Elettrodo a lancetta, angolato
80-515-04-04	1	Electrode couteau	Elettrodo a bisturi
80-520-04-04	1	Electrode aiguille	Elettrodo ad ago
80-540-04-04	1	Electrode anse en fil, Ø 5 mm	Elettrodo ad ansa, Ø 5 mm
80-542-04-04	1	Electrode anse en fil, Ø 10 mm	Elettrodo ad ansa, Ø 10 mm
80-550-04-04	1	Electrode boucle, Ø 10 mm	Elettrodo ad ansa a nastro, Ø 10 mm
80-552-04-04	1	Electrode boucle, Ø 15 mm	Elettrodo ad ansa a nastro, Ø 15 mm
80-560-04-04	1	Electrode boule, Ø 2 mm	Elettrodo a sfera, Ø 2 mm
80-562-04-04	1	Electrode boule, Ø 4 mm	Elettrodo a sfera, Ø 4 mm
80-563-04-04	1	Electrode boule, Ø 5 mm	Elettrodo a sfera, Ø 5 mm
80-570-04-04	1	Electrode plaque, 8 x 10 mm	Elettrodo a piastra, 8 x 10 mm

80-150-00-04		Lot d'accessoires bipolaire pour KLS Martin maXium® m, ME MB 3/ME MB 1*	Serie di accessori bipolare per KLS Martin maXium® m, ME MB 3/ME MB 1*
80-287-53-04	1	Câble de raccordement pour pinces bipolaires	Cavo di connessione per pinze bipolari
80-924-16-04	1	Pince bipolaire, droite, mousse, 16 cm/6 1/4"	Pinza bipolare, retta, smussa, 16 cm/6 1/4"
80-945-20-04	1	Pince bipolaire, en forme baïonnette, mousse, 20 cm/8"	Pinza bipolare, a forma baionetta, smussa, 20 cm/8"
80-925-16-04	1	Pince bipolaire, coudée, mousse, 16 cm/6 1/4"	Pinza bipolare, angolata, smussa, 16 cm/6 1/4"
80-925-20-04	1	Pince bipolaire, coudée, mousse, 20 cm/8"	Pinza bipolare, angolata, smussa, 20 cm/8"
80-924-20-04	1	Pince bipolaire, droite, mousse, 20 cm/8"	Pinza bipolare, retta, smussa, 20 cm/8"

* Seulement en connexion d'interrupteur à pédale

* Solamente in connessione con interruttore a pedale

80-150-01-04		Zubehörsatz bipolar mit nonStick-red-Pinzetten für KLS Martin maXium® m, ME MB 3/ ME MB 1*	Set bipolar accessories with nonStick red forceps for KLS Martin maXium® m, ME MB 3/ ME MB 1*	Juego de accesorios bipolar con pinzas bipolares nonStick red para KLS Martin maXium® m, ME MB 3/ ME MB 1*
80-287-53-04	1	Anschlusskabel für bipolare Pinzetten	Connection cable for bipolar forceps	Cable de conexión para pinzas bipolares
80-986-17-04	1	Bipolare Pinzette, nonStick red, gerade, stumpf, 16 cm/6 1/4"	Bipolar forceps, nonStick red, straight, blunt, 16 cm/6 1/4"	Pinza bipolar, nonStick red, recta, roma, 16 cm/6 1/4"
80-992-20-04	1	Bipolare Pinzette, nonStick red, bajonettförmig, stumpf, 20 cm/8"	Bipolar forceps, nonStick red, bayonet-shaped, blunt, 20 cm/8"	Pinza bipolar, nonStick red, en forma bayoneta, roma, 20 cm/8"
80-987-17-04	1	Bipolare Pinzette, nonStick red, abgewinkelt, stumpf, 16 cm/6 1/4"	Bipolar forceps, nonStick red, angled, blunt, 16 cm/6 1/4"	Pinza bipolar, nonStick red, acodada, roma, 16 cm/6 1/4"
80-987-20-04	1	Bipolare Pinzette, nonStick red, abgewinkelt, stumpf, 20 cm/8"	Bipolar forceps, nonStick red, angled, blunt, 20 cm/8"	Pinza bipolar, nonStick red, acodada, roma, 20 cm/8"
80-986-20-04	1	Bipolare Pinzette, nonStick red, gerade, stumpf, 20 cm/8"	Bipolar forceps, nonStick red, straight, blunt, 20 cm/8"	Pinza bipolar, nonStick red, recta, roma, 20 cm/8"

* Nur in Verbindung mit Fußschalter

* Only in connection with foot switch

* Solamente en conexión con interruptor de pie

80-140-01-04		Großer Zubehörsatz, Fußaktivierung für ME MB 3/ ME MB 1/ maXium® m, bestehend aus:	Accessory set, large for foot switch operation ME MB 3/ ME MB 1/ maXium® m, consisting of:	Juego de accesorios, grande con interruptor de pedal ME MB 3/ ME MB 1/ maXium® m, compuesto de:
80-220-02-04	1	smartPen Elektroden-Handgriff ohne Tasten für 4-mm-Elektroden, mit KLS Martin-Stecker	smartPen electrode handle without pushbuttons for 4-mm electrodes, with KLS Martin plug	Mango porta-electrodos smartPen sin teclas, para electrodos de 4 mm, con clavija de KLS Martin
80-342-03-04	1	Gummi-Neutralelektrode 15 x 26 cm, 4 m Kabel	Rubber neutral electrode, 15 x 26 cm, with connection cable of 4 m	Placa neutra de goma, 15 x 26 cm, cable de conexión de 4 m
80-371-00-04	2	Gummibinden, gelocht, 100 cm	Rubber bands, with holes, 100 cm	Cintas de goma, perforadas, 100 cm
80-371-01-04	2	Knöpfe für Gummibinde	Buttons for rubber band	Botones para la cinta de goma
80-416-00-01	1	Elektroden-Ständer für 16 Elektroden	Electrode box for 16 electrodes	Caja para 16 electrodos
80-505-00-04	1	Reinigungspad für Elektroden, steril verpackt, VE = 100 Stck.	Cleaning pad for electrodes, sterile packed, SU = 100/pack	Almohadilla de limpieza para electrodos, embalado estéril, UV = 100 piezas
80-510-04-04	1	Lanzettelektrode, gerade	Lancet electrode, straight	Electrodo de lanceta, recto
80-511-04-04	1	Lanzettelektrode, abgewinkelt	Lancet electrode, angled	Electrodo de lanceta, acodado
80-515-04-04	1	Messerelektrode	Knife electrode	Electrodo de cuchillo
80-520-04-04	1	Nadelelektrode	Needle electrode	Electrodo de aguja
80-540-04-04	1	Drahtschlingenelektrode, Ø 5 mm	Wire loop electrode, Ø 5 mm	Electrodo de asa de alambre, Ø 5 mm
80-542-04-04	1	Drahtschlingenelektrode, Ø 10 mm	Wire loop electrode, Ø 10 mm	Electrodo de asa de alambre, Ø 10 mm
80-550-04-04	1	Bandschlingenelektrode, Ø 10 mm	Ribbon loop electrode, Ø 10 mm	Electrodo de asa de cinta, Ø 10 mm
80-552-04-04	1	Bandschlingenelektrode, Ø 15 mm	Ribbon loop electrode, Ø 15 mm	Electrodo de asa de cinta, Ø 15 mm
80-560-04-04	1	Kugelelektrode, Ø 2 mm	Ball electrode, Ø 2 mm	Electrodo de bola, Ø 2 mm
80-562-04-04	1	Kugelelektrode, Ø 4 mm	Ball electrode, Ø 4 mm	Electrodo de bola, Ø 4 mm
80-563-04-04	1	Kugelelektrode, Ø 5 mm	Ball electrode, Ø 5 mm	Electrodo de bola, Ø 5 mm
80-570-04-04	1	Plattenelektrode, 8 x 10 mm	Plate electrode, 8 x 10 mm	Electrodo de placa, 8 x 10 mm
80-830-00-04	1	Doppelpedal-Fußschalter, AP-geprüft, 5 m Kabel, explosionsgeschützt	Double-pedal foot switch, anti-explosive, with connection cable of 5 m	Interruptor de pedal doble, anti-explosivo, cable de conexión de 5 m



80-150-01-04		Lot d'accessoires bipolaire avec pinces bipolaires nonStick red pour KLS Martin maXium® m, ME MB 3/ ME MB 1*	Serie di accessori bipolare con pinze bipolari nonStick red per KLS Martin maXium® m, ME MB 3/ ME MB 1*
80-287-53-04	1	Câble de raccordement pour pinces bipolaires	Cavo di connessione per pinze bipolari
80-986-17-04	1	Pince bipolaire, nonStick red, droite, mousse, 16 cm/6 1/4"	Pinza bipolare, nonStick red, retta, smussa, 16 cm/6 1/4"
80-992-20-04	1	Pince bipolaire, nonStick red, en forme baïonnette, mousse, 20 cm/8"	Pinza bipolare, nonStick red, a forma baionetta, smussa, 20 cm/8"
80-987-17-04	1	Pince bipolaire, nonStick red, coudée, mousse, 16 cm/6 1/4"	Pinza bipolare, nonStick red, angolata, smussa, 16 cm/6 1/4"
80-987-20-04	1	Pince bipolaire, nonStick red, coudée, mousse, 20 cm/8"	Pinza bipolare, nonStick red, angolata, smussa, 20 cm/8"
80-986-20-04	1	Pince bipolaire, nonStick red, droite, mousse, 20 cm/8"	Pinza bipolare, nonStick red, retta, smussa, 20 cm/8"

* Seulement en connexion d'interrupteur à pédale

* Solamente in connessione con interruttore a pedale

80-140-01-04		Grand lot d'accessoires pour commande par pédale ME MB 3/ ME MB 1/ maXium® m, composé de:	Serie grande di accessori standard per attivazione a pedale ME MB 3/ ME MB 1/ maXium® m, composta di:
80-220-02-04	1	Manche porte-électrode smartPen sans interrupteur, pour electrodes de 4 mm, avec fiche de KLS Martin	Manico portaelettrodi smartPen senza tasti, per elettrodi da 4 mm, con spina da KLS Martin
80-342-03-04	1	Electrode neutre en caoutchouc, 15 x 26 cm, avec câble de raccordement de 4 m	Elettrodo neutro di gomma, 15 x 26 cm, cavo di connessione di m 4
80-371-00-04	2	Bandes caoutchouc, perforées, 100 cm	Nastri di gomma, perforati, 100 cm
80-371-01-04	2	Boutons pour bande caoutchouc	Bottoni per nastro di gomma
80-416-00-01	1	Boîte pour 16 électrodes	Supporto per 16 elettrodi in scatola
80-505-00-04	1	Tampon de nettoyage pour électrodes, emballage stérile, UC = 100 pièces	Tampone di pulizia per elettrodi, imballaggio sterile, UV = 100 pezzi
80-510-04-04	1	Electrode lancette, droite	Elettrodo a lancetta, retto
80-511-04-04	1	Electrode lancette, coudée	Elettrodo a lancetta, angolato
80-515-04-04	1	Electrode couteau	Elettrodo a bisturi
80-520-04-04	1	Electrode aiguille	Elettrodo ad ago
80-540-04-04	1	Electrode anse en fil, Ø 5 mm	Elettrodo ad ansa, Ø 5 mm
80-542-04-04	1	Electrode anse en fil, Ø 10 mm	Elettrodo ad ansa, Ø 10 mm
80-550-04-04	1	Electrode boucle, Ø 10 mm	Elettrodo ad ansa a nastro, Ø 10 mm
80-552-04-04	1	Electrode boucle, Ø 15 mm	Elettrodo ad ansa a nastro, Ø 15 mm
80-560-04-04	1	Electrode boule, Ø 2 mm	Elettrodo a sfera, Ø 2 mm
80-562-04-04	1	Electrode boule, Ø 4 mm	Elettrodo a sfera, Ø 4 mm
80-563-04-04	1	Electrode boule, Ø 5 mm	Elettrodo a sfera, Ø 5 mm
80-570-04-04	1	Electrode plaque, 8 x 10 mm	Elettrodo a piastra, 8 x 10 mm
80-830-00-04	1	Interrupteur à pédale double, anti-explosif, avec câble de raccordement de 5 m	Interruttore a pedale doppio, anti-deflagrante, con cavo di connessione di 5 m

80-140-02-04		Kleiner Zubehörsatz, Handaktivierung für ME MB 3/ ME MB 1/ maXium® m, bestehend aus:	Accessory set, small for hand switch operation ME MB 3/ ME MB 1/ maXium® m, consisting of:	Juego de accesorios, pequeño con interruptor digital ME MB 3/ ME MB 1/ maXium® m, compuesto de:
80-217-13-04	1	smartPen Elektroden-Handgriff mit zwei Tasten für 4-mm-Elektroden, mit KLS Martin-Stecker	smartPen electrode handle with two pushbuttons for 4-mm electrodes, with KLS Martin plug	Mango porta-electrodos smartPen con dos teclas, para electrodos de 4 mm, con clavija de KLS Martin
80-342-03-04	1	Gummi-Neutralelektrode 15 x 26 cm, 4 m Kabel	Rubber neutral electrode, 15 x 26 cm, with connection cable of 4 m	Placa neutra de goma, 15 x 26 cm, cable de conexión de 4 m
80-372-00-04	1	Textilband mit Klettverschluss, 90 cm	Textile band with velcro strap, 90 cm	Tira auto-adhesiva, 90 cm
80-505-00-04	1	Reinigungspad für Elektroden, steril verpackt, VE = 100 Stck.	Cleaning pad for electrodes, sterile packed, SU = 100/pack	Almohadilla de limpieza para electrodos, embalado estéril, UV = 100 piezas
80-511-04-04	1	Lanzettelektrode, abgewinkelt	Lancet electrode, straight	Electrodo de lanceta, acodado
80-515-04-04	1	Messerelektrode	Knife electrode	Electrodo de cuchillo
80-520-04-04	1	Nadelelektrode	Needle electrode	Electrodo de aguja
80-562-04-04	1	Kugelelektrode, Ø 4 mm	Ball electrode, Ø 4 mm	Electrodo de bola, Ø 4 mm

Ergänzungs-Sets

Supplementary sets

Juegos suplementarios

80-160-00-04		Standard-Set A für ME MB 3 m, ME MB 1 (und andere KLS-Martin-Großgeräte) bestehend aus:	Standard Set A for ME MB 3 m, ME MB 1 (and other KLS Martin major electrosurgery units) consisting of:	Juego estándar A para ME MB 3 m, ME MB 1 (y otros equipos grandes KLS Martin) compuesto de:
80-221-02-04	1	Einmalhandgriffe, VE = 10 Stck.	Disposable electrode handles, SU = 10/pack	Mangos desechables, UV = 10 piezas
80-344-09-04	1	PCS-DuoSafe-Einmal-Neutralelektroden, VE = 50 Stck.	Disposable DuoSafe neutral electrodes, SU = 50/pack	Placas neutras desechables PCS DuoSafe, UV = 50 piezas
80-294-40-04	1	Neutralelektroden-Anschlusskabel KLS Martin	KLS Martin connection cable for disposable neutral electrodes	Cable de conexión KLS Martin para placa neutra
80-505-00-04	1	Reinigungspad für Elektroden, steril verpackt, VE = 100 Stck.	Cleaning pad for electrodes, sterile packed, SU = 100/pack	Almohadilla de limpieza para electrodos, embalado estéril, UV = 100 piezas
80-811-30-04	1	Fußschalter	Foot switch	Interruptor de pedal

80-160-01-04		Standard-Set B für ME MB 3 i und ME MB 2 i maXium® i, bestehend aus:	Standard Set B for ME MB 3 i and ME MB 2 i maXium® i, consisting of:	Juego estándar B para ME MB 3 i y ME MB 2 i maXium® i, compuesto de:
80-221-02-04	1	Einmalhandgriffe, VE = 10 Stck.	Disposable electrode handles, SU = 10/pack	Mangos desechables, UV = 10 piezas
80-344-09-04	1	PCS-DuoSafe-Einmal-Neutralelektroden, VE = 50 Stck.	Disposable DuoSafe neutral electrodes, SU = 50/pack	Placas neutras desechables PCS DuoSafe, UV = 50 piezas
80-294-44-04	1	Neutralelektroden-Anschlusskabel Valleylab	Connection cable Valleylab for disposable neutral electrodes	Cable de conexión Valleylab para electrodo neutro
80-505-00-04	1	Reinigungspad für Elektroden, steril verpackt, VE = 100 Stck.	Cleaning pad for electrodes, sterile packed, SU = 100/pack	Almohadilla de limpieza para electrodos, embalado estéril, UV = 100 piezas
80-811-30-04	1	Fußschalter	Foot switch	Interruptor de pedal

80-140-02-04		Petit lot d'accessoires pour commande digitale ME MB 3/ ME MB 1/ maXium® m, composé de:	Serie piccola di accessori standard per attivazione a mano ME MB 3/ ME MB 1/ maXium® m, composta di:
80-217-13-04	1	Manche porte-électrode smartPen avec interrupteur digital double, pour électrodes de 4 mm, avec fiche de KLS Martin	Manico portaelettrodi smartPen con due tasti, per elettrodi da 4 mm, con spina da KLS Martin
80-342-03-04	1	Électrode neutre en caoutchouc, 15 x 26 cm, avec câble de raccordement de 4 m	Elettrodo neutro di gomma, 15 x 26 cm, cavo di connessione di 4 m
80-372-00-04	1	Bande auto-adhésive, 90 cm	Nastro tessile auto-adesivo, 90 cm
80-505-00-04	1	Tampon de nettoyage pour électrodes, emballage stérile, UC = 100 pièces	Tampone di pulizia per elettrodi, imballaggio sterile, UV = 100 pezzi
80-511-04-04	1	Électrode lancette, coudée	Elettrodo a lancetta, angolato
80-515-04-04	1	Électrode couteau	Elettrodo a bisturi
80-520-04-04	1	Électrode aiguille	Elettrodo ad ago
80-562-04-04	1	Électrode boule, Ø 4 mm	Elettrodo a sfera, Ø 4 mm

Lots supplémentaires

Set supplementari

80-160-00-04		Lot standard A pour ME MB 3 m, ME MB 1 (et autres grands appareils KLS Martin) composé de:	Set standard A per l'apparecchio ME MB 3 m, ME MB 1 (e altri grandi apparecchi KLS Martin) composto di:
80-221-02-04	1	Manches à usage unique, UC = 10 pièces	Manici monouso, UV = 10 pezzi
80-344-09-04	1	Électrodes neutres à usage unique type PCS DuoSafe, UC = 50 pièces	Elettrodi neutri PCS DuoSafe monouso, UV = 50 pezzi
80-294-40-04	1	Câble de raccordement à électrode neutre KLS Martin	Cavo di connessione KLS Martin per elettrodo neutro
80-505-00-04	1	Tampon de nettoyage pour électrodes, emballage stérile, UC = 100 pièces	Tampone di pulizia per elettrodi, imballaggio sterile, UV = 100 pezzi
80-811-30-04	1	Interrupteur à pédale	Interruttore a pedale

80-160-01-04		Lot standard B pour ME MB 3 i et ME MB 2 i maXium® i, composé de:	Set standard B per l'apparecchio ME MB 3 i e ME MB 2 i maXium® i, composto di:
80-221-02-04	1	Manches à usage unique, UC = 10 pièces	Manici monouso, UV = 10 pezzi
80-344-09-04	1	Électrodes neutres à usage unique type PCS DuoSafe, UC = 50 pièces	Elettrodi neutri PCS DuoSafe monouso, UV = 50 pezzi
80-294-44-04	1	Câble de raccordement à électrode neutre Valleylab	Cavo di connessione Valleylab per elettrodo neutro
80-505-00-04	1	Tampon de nettoyage pour électrodes, emballage stérile, UC = 100 pièces	Tampone di pulizia per elettrodi, imballaggio sterile, UV = 100 pezzi
80-811-30-04	1	Interrupteur à pédale	Interruttore a pedale

80-160-02-04		Standard-Set C für ME MB 3 i, ME MB 2 i, maXium® i (und weitere Geräte mit internationalem Anschluss) bestehend aus:	Standard set C for ME MB 3 i, ME MB 2 i, maXium® i (and other units with international connector sockets) consisting of:	Juego estándar C para ME MB 3 i, ME MB 2 i, maXium® i (y otros equipos con conexión internacional) compuesto de:
80-210-02-04	1	smartPen Elektroden-Handgriff ohne Tasten für 2,4-mm-Elektroden, mit KLS Martin-Stecker	smartPen electrode handle without pushbuttons, for 2.4-mm electrodes, with KLS Martin plug	Mango porta-electrodos smartPen sin teclas, para electrodos de 2,4 mm, con clavija de KLS Martin
80-562-08-04	5	Kugelelektrode Ø 4 mm, Schaft Ø 2,4 mm	Ball electrode Ø 4 mm, shaft Ø 2.4 mm	Electrodo de bola Ø 4 mm, vástago Ø 2,4 mm
80-520-08-04	5	Nadelelektrode, Schaft Ø 2,4 mm	Needle electrode, shaft Ø 2.4 mm	Electrodo de aguja, vástago Ø 2,4 mm
80-515-08-04	5	Messerelektrode, Schaft Ø 2,4 mm	Knife electrode, shaft Ø 2.4 mm	Electrodo de cuchillo, vástago Ø 2,4 mm
80-510-08-04	5	Lanzettelektrode, Schaft Ø 2,4 mm	Lancet electrode, shaft Ø 2.4 mm	Electrodo de lanceta, vástago Ø 2,4 mm
80-542-08-04	5	Drahtschlingenelektrode Ø 10 mm, Schaft Ø 2,4 mm	Wire loop electrode Ø 10 mm, shaft Ø 2.4 mm	Electrodo de asa de alambre Ø 10 mm, vástago Ø 2,4 mm
80-344-09-04	1	PCS-DuoSafe-Einmal-Neutralelektroden, VE = 50 Stck.	Disposable DuoSafe neutral electrodes, SU = 50/pack	Placas neutras desechables PCS DuoSafe, UV = 50 piezas
80-294-44-04	1	Neutralelektroden-Anschlusskabel mit i-Stecker (Typ Valleylab)	Connection cable for neutral electrodes with „i“-Version plug (type Valleylab)	Cable de conexión para placas neutras con clavija versión "i" (tipo Valleylab)
80-811-30-04	1	Doppelpedal-Fußschalter	Double-pedal foot switch	Interruptor de pie doble
80-505-00-04	1	Reinigungspad für Elektroden, steril verpackt, VE = 100 Stck.	Cleaning pad for electrodes, sterile packed, SU = 100/pack	Almohadilla de limpieza para electrodos, embalado estéril, UV = 100 piezas



80-160-02-04		Lot standard C pour ME MB 3 i, ME MB 2 i, maXium® i (et autres appareils avec connexion internationale) composé de:	Set standard C per l'apparecchio ME MB 3 i, ME MB 2 i, maXium® i (e altri apparecchi con connessione internazionale) composto di:
80-210-02-04	5	Manche porte-électrode smartPen sans interrupteur pour 2,4 mm électrodes, avec fiche KLS Martin	Manico portaelettrodi smartPen senza tasti per 2,4 mm elettrodi, con spina KLS Martin
80-562-08-04	5	Electrode boule Ø 4 mm, tige Ø 2,4 mm	Elettrodo a sfera Ø 4 mm, asta Ø 2,4 mm
80-520-08-04	5	Electrode aiguille, tige Ø 2,4 mm	Elettrodo ad ago, asta Ø 2,4 mm
80-515-08-04	5	Electrode couteau, tige Ø 2,4 mm	Elettrodo a bisturi, asta Ø 2,4 mm
80-510-08-04	5	Electrode lancette, tige Ø 2,4 mm	Elettrodo a lancetta, asta Ø 2,4 mm
80-542-08-04	5	Electrode anse en fil Ø 10 mm, tige Ø 2,4 mm	Elettrodo ad ansa di filo Ø 10 mm, asta Ø 2,4 mm
80-344-09-04	1	Électrodes neutres à usage unique type PCS DuoSafe, UC = 50 pièces	Elettrodi neutri PCS DuoSafe monouso, UV = 50 pezzi
80-294-44-04	1	Câble de raccordement pour électrodes neutres avec fiche version «i» (type Valleylab)	Cavo di connessione per elettrodi neutri con spina versione "i" (tipo Valleylab)
80-811-30-04	1	Interrupteur à pédale double	Interruttore a doppio pedale
80-505-00-04	1	Tampon de nettoyage pour électrodes, emballage stérile, UC = 100 pièces	Tampone di pulizia per elettrodi, imballaggio sterile, UV = 100 pezzi

maXium®-Zubehörsätze für die Offene Chirurgie
maXium® accessory sets for open surgery
Juegos de accesorios maXium® para la cirugía abierta
Jeux d'accessoires maXium® pour la chirurgie ouverte
Serie di accessori maXium® per la chirurgia aperta

80-042-10-04		Satz Zubehör für maXium® m, bestehend aus:	Accessory set for maXium® m, consisting of:	Juego de accesorios para maXium® m, compuesto de:
80-830-01-04	1	SWAP-Mode-Doppelpedalfußschalter, 5 m Kabel, explosionsgeschützt, AP-geprüft, IP X8, eintauchbar	SWAP mode double-pedal foot switch, 5 m cable, explosion-proof, AP-tested, IP X8, immersible	Interruptor de pie de doble pedal con modo SWAP, cable 5 m, antiexplosivo, controlada su aptitud para anestésicos, IP X8, sumergible
80-830-02-04	1	Einpedalfußschalter, 5 m Kabel, explosionsgeschützt, AP-geprüft, IP X8, eintauchbar	Single-pedal foot switch, 5 m cable, explosion-proof, AP-tested, IP X8, immersible	Interruptor de pie de un pedal, cable 5 m, antiexplosivo, controlada su aptitud para anestésicos, IP X8, sumergible
80-260-50-04	1	Potentialausgleichskabel	Potential equalization cable	Cable de conexión equipotencial
80-217-13-04	2	smartPen Elektroden-Handgriff mit zwei Tasten, für 4-mm-Elektroden, mit KLS Martin-Stecker	smartPen electrode handle with two pushbuttons, for 4-mm electrodes, with KLS Martin plug	Mango porta-electrodos smartPen con dos teclas, para electrodos de 4 mm, con clavija de KLS Martin
80-510-04-04	2	Lanzettelektrode	Lancet electrode	Electrodo de lanceta
80-511-04-04	2	Lanzettelektrode, abgewinkelt	Lancet electrode, angled	Electrodo de lanceta, acodado
80-515-04-04	2	Messerelektrode	Knife electrode	Electrodo de cuchillo
80-560-04-04	2	Kugelelektrode Ø 2 mm	Ball electrode Ø 2 mm	Electrodo de bola Ø 2 mm
80-344-09-04	1	PCS-DuoSafe-Einmal-Neutralelektroden, VE = 50 Stck.	Disposable DuoSafe neutral electrodes, SU = 50/pack	Placas neutras desechables PCS DuoSafe UV = 50 piezas
80-294-40-04	1	Anschlusskabel für Neutralelektroden	Connection cable for neutral electrodes	Cable de conexión para placas neutras
80-924-16-04	2	Bipolare Pinzette, gerade, stumpf	Bipolar forceps, straight, blunt	Pinzas bipolares, rectas, romas
80-287-33-04	4	Anschlusskabel für bipolare Instrumente	Connection cable for bipolar instruments	Cable de conexión para instrumentos bipolares
80-975-23-04	2	marClamp® IQ, gebogene Version, 23 cm	marClamp® IQ, curved version, 23 cm	marClamp® IQ, versión curva, 23 cm
80-570-23-04	2	marCut®, 23 cm	marCut®, 23 cm	marCut®, 23 cm
80-505-00-04	1	Reinigungspad für Elektroden, steril verpackt, VE = 100 Stck.	Cleaning pad for electrodes, sterile packed, SU = 100/pack	Almohadilla de limpieza para electrodos, embalado estéril, UV = 100 piezas

80-042-20-04		Satz Zubehör für maXium® i, bestehend aus:	Accessory set for maXium® i, consisting of:	Juego de accesorios para maXium® i, compuesto de:
80-830-01-04	1	SWAP-Mode-Doppelpedalfußschalter, 5 m Kabel, explosionsgeschützt, AP-geprüft, IP X8, eintauchbar	SWAP mode double-pedal foot switch, 5 m cable, explosion-proof, AP-tested, IP X8, immersible	Interruptor de pie de doble pedal con modo SWAP, cable 5 m, antiexplosivo, controlada su aptitud para anestésicos, IP X8, sumergible
80-830-02-04	1	Einpedalfußschalter, 5 m Kabel, explosionsgeschützt, AP-geprüft, IP X8, eintauchbar	Single-pedal foot switch, 5 m cable, explosion-proof, AP-tested, IP X8, immersible	Interruptor de pie de un pedal, cable 5 m, antiexplosivo, controlada su aptitud para anestésicos, IP X8, sumergible
80-260-50-04	1	Potentialausgleichskabel	Potential equalization cable	Cable de conexión equipotencial
80-210-13-04	2	smartPen Elektroden-Handgriff mit zwei Tasten für 4-mm-Elektroden, mit 3-PIN-Stecker	smartPen electrode handle with two pushbuttons, for 4-mm electrodes, with 3-pin plug	Mango porta-electrodos smartPen con dos teclas, para electrodos 4 mm, con clavija de 3 patillas
80-510-04-04	2	Lanzettelektrode	Lancet electrode	Electrodo de lanceta
80-511-04-04	2	Lanzettelektrode, abgewinkelt	Lancet electrode, angled	Electrodo de lanceta, acodado
80-515-04-04	2	Messerelektrode	Knife electrode	Electrodo de cuchillo
80-560-04-04	2	Kugelelektrode Ø 2 mm	Ball electrode Ø 2 mm	Electrodo de bola Ø 2 mm
80-344-09-04	1	PCS-DuoSafe-Einmal-Neutralelektroden, VE = 50 Stck.	Disposable DuoSafe neutral electrodes, SU = 50/pack	Placas neutras desechables PCS DuoSafe UV = 50 piezas
80-294-40-04	1	Anschlusskabel für Neutralelektroden	Connection cable for neutral electrodes	Cable de conexión para placas neutras
80-924-16-04	2	Bipolare Pinzette, gerade, stumpf	Bipolar forceps, straight, blunt	Pinzas bipolares, rectas, romas
80-287-89-04	4	Anschlusskabel für bipolare Instrumente	Connection cable for bipolar instruments	Cable de conexión para instrumentos bipolares
80-975-23-04	2	marClamp® IQ, gebogene Version, 23 cm	marClamp® IQ, curved version, 23 cm	marClamp® IQ, versión curva, 23 cm
80-570-23-04	2	marCut®, 23 cm	marCut®, 23 cm	marCut®, 23 cm
80-505-00-04	1	Reinigungspad für Elektroden, steril verpackt, VE = 100 Stck.	Cleaning pad for electrodes, sterile packed, SU = 100/pack	Almohadilla de limpieza para electrodos, embalado estéril, UV = 100 piezas

80-042-10-04		Lot d'accessoires pour maXium® m, composé de:	Serie di accessori per maXium® m, composta di:
80-830-01-04	1	Interrupteur à pédale double avec mode SWAP, câble 5 m, anti-explosif, catégorie AP, IP X8, immergeable	Interruttore a pedale doppio con modo SWAP, cavo 5 m, anti-deflagrante, testato AP, IP X8, immergibile
80-830-02-04	1	Interrupteur à une pédale, câble 5 m, anti-explosif, catégorie AP, IP X8, immergeable	Interruttore monopedale, cavo 5 m, anti-deflagrante, testato AP, IP X8, immergibile
80-260-50-04	1	Câble de compensation de potentiel	Cavo per collegamento equipotenziale
80-217-13-04	2	Manche porte-électrode smartPen avec interrupteur digital double, pour électrodes de 4 mm, avec fiche de KLS Martin	Manico portaelettrodi smartPen con due tasti, per elettrodi da 4 mm, con spina da KLS Martin
80-510-04-04	2	Electrode lancette	Elettrodo a lancetta
80-511-04-04	2	Electrode lancette, coudée	Elettrodo a lancetta, angolato
80-515-04-04	2	Electrode couteau	Elettrodo a bisturi
80-560-04-04	2	Electrode boule Ø 2 mm	Elettrodo a sfera Ø 2 mm
80-344-09-04	1	Electrodes neutres à usage unique type PCS DuoSafe UC = 50 pièces	Elettrodi neutri PCS DuoSafe monouso UV = 50 pezzi
80-294-40-04	1	Câble de raccordement pour électrodes neutres	Cavo di connessione per elettrodi neutri
80-924-16-04	2	Pinces bipolaires, droites, mousses	Pinze bipolari, strette, smusse
80-287-33-04	4	Câble de raccordement pour instruments bipolaires	Cavo di connessione per strumenti bipolari
80-975-23-04	2	marClamp® IQ, version courbe, 23 cm	marClamp® IQ, versione curva, 23 cm
80-570-23-04	2	marCut®, 23 cm	marCut®, 23 cm
80-505-00-04	1	Tampon de nettoyage pour électrodes, emballage stérile, UC = 100 pièces	Tampone di pulizia per elettrodi, imballaggio sterile, UV = 100 pezzi

80-042-20-04		Lot d'accessoires pour maXium® i, composé de:	Serie di accessori per maXium® i, composta di:
80-830-01-04	1	Interrupteur à pédale double avec mode SWAP, câble 5 m, anti-explosif, catégorie AP, IP X8, immergeable	Interruttore a pedale doppio con modo SWAP, cavo 5 m, anti-deflagrante, testato AP, IP X8, immergibile
80-830-02-04	1	Interrupteur à une pédale, câble 5 m, anti-explosif, catégorie AP, IP X8, immergeable	Interruttore monopedale, cavo 5 m, anti-deflagrante, testato AP, IP X8, immergibile
80-260-50-04	1	Câble de compensation de potentiel	Cavo per collegamento equipotenziale
80-210-13-04	2	Manche porte-électrode smartPen avec interrupteur digital double, pour électrodes de 4 mm, avec fiche à 3 broches	Manico portaelettrodi smartPen con due tasti, per elettrodi da 4 mm, con spina a 3-spire
80-510-04-04	2	Electrode lancette	Elettrodo a lancetta
80-511-04-04	2	Electrode lancette, coudée	Elettrodo a lancetta, angolato
80-515-04-04	2	Electrode couteau	Elettrodo a bisturi
80-560-04-04	2	Electrode boule Ø 2 mm	Elettrodo a sfera Ø 2 mm
80-344-09-04	1	Electrodes neutres à usage unique type PCS DuoSafe UC = 50 pièces	Elettrodi neutri PCS DuoSafe monouso UV = 50 pezzi
80-294-40-04	1	Câble de raccordement pour électrodes neutres	Cavo di connessione per elettrodi neutri
80-924-16-04	2	Pinces bipolaires, droites, mousses	Pinze bipolari, strette, smusse
80-287-89-04	4	Câble de raccordement pour instruments bipolaires	Cavo di connessione per strumenti bipolari
80-975-23-04	2	marClamp® IQ, version courbe, 23 cm	marClamp® IQ, versione curva, 23 cm
80-570-23-04	2	marCut®, 23 cm	marCut®, 23 cm
80-505-00-04	1	Tampon de nettoyage pour électrodes, emballage stérile, UC = 100 pièces	Tampone di pulizia per elettrodi, imballaggio sterile, UV = 100 pezzi

maXium®-Zubehörsätze für die Offene Chirurgie
 maXium® accessory sets for open surgery
 Juegos de accesorios maXium® para la cirugía abierta
 Jeux d'accessoires maXium® pour la chirurgie ouverte
 Serie di accessori maXium® per la chirurgia aperta

80-042-40-04		Satz Zubehör für maXium® e, bestehend aus:	Accessory set for maXium® e, consisting of:	Juego de accesorios para maXium® e, compuesto de:
80-830-01-04	1	SWAP-Mode-Doppelpedalfußschalter, 5 m Kabel, explosionsgeschützt, AP-geprüft, IP X8, eintauchbar	SWAP mode double-pedal foot switch, 5 m cable, explosion-proof, AP-tested, IP X8, immersible	Interrupor de pie de doble pedal con modo SWAP, cable 5 m, antiexplosivo, controlada su aptitud para anestésicos, IP X8, sumergible
80-830-02-04	1	Einpedalfußschalter, 5 m Kabel, explosionsgeschützt, AP-geprüft, IP X8, eintauchbar	Single-pedal foot switch, 5 m cable, explosion-proof, AP-tested, IP X8, immersible	Interrupor de pie de un pedal, cable 5 m, antiexplosivo, controlada su aptitud para anestésicos, IP X8, sumergible
80-260-50-04	1	Potentialausgleichskabel	Potential equalization cable	Cable de conexión equipotencial
80-210-18-04	2	smartPen Elektroden-Handgriff mit zwei Tasten für 4-mm-Elektroden, mit Erbe-Stecker	smartPen electrode handle with two pushbuttons, for 4-mm electrodes, with Erbe plug	Mango porta-electrodos smartPen con dos teclas, para electrodos 4 mm, con clavija de Erbe
80-510-04-04	2	Lanzettelektrode	Lancet electrode	Electrodo de lanceta
80-511-04-04	2	Lanzettelektrode, abgewinkelt	Lancet electrode, angled	Electrodo de lanceta, acodado
80-515-04-04	2	Messerelektrode	Knife electrode	Electrodo de cuchillo
80-560-04-04	2	Kugelelektrode Ø 2 mm	Ball electrode Ø 2 mm	Electrodo de bola Ø 2 mm
80-344-09-04	1	PCS-DuoSafe-Einmal-Neutralelektroden, VE = 50 Stck.	Disposable DuoSafe neutral electrodes, SU = 50/pack	Placas neutras desechables PCS DuoSafe UV = 50 piezas
80-294-40-04	1	Anschlusskabel für Neutralelektroden	Connection cable for neutral electrodes	Cable de conexión para placas neutras
80-924-16-04	2	Bipolare Pinzette, gerade, stumpf	Bipolar forceps, straight, blunt	Pinzas bipolares, rectas, romas
80-287-89-04	4	Anschlusskabel für bipolare Instrumente	Connection cable for bipolar instruments	Cable de conexión para instrumentos bipolares
80-975-23-04	2	marClamp® IQ, gebogene Version, 23 cm	marClamp® IQ, curved version, 23 cm	marClamp® IQ, versión curva, 23 cm
80-570-23-04	2	marCut®, 23 cm	marCut®, 23 cm	marCut®, 23 cm
80-505-00-04	1	Reinigungspad für Elektroden, steril verpackt, VE = 100 Stck.	Cleaning pad for electrodes, sterile packed, SU = 100/pack	Almohadilla de limpieza para electrodos, embalado estéril, UV = 100 piezas

80-042-40-04		Lot d'accessoires pour maXium® e, composé de:	Serie di accessori per maXium® e, composta di:
80-830-01-04	1	Interrupteur à pédale double avec mode SWAP, câble 5 m, anti-explosif, catégorie AP, IP X8, immergeable	Interruttore a pedale doppio con modo SWAP, cavo 5 m, anti-deflagrante, testato AP, IP X8, immergibile
80-830-02-04	1	Interrupteur à une pédale, câble 5 m, anti-explosif, catégorie AP, IP X8, immergeable	Interruttore monopedale, cavo 5 m, anti-deflagrante, testato AP, IP X8, immergibile
80-260-50-04	1	Câble de compensation de potentiel	Cavo per collegamento equipotenziale
80-210-18-04	2	Manche porte-électrode smartPen avec interrupteur digital double, pour électrodes de 4 mm, avec fiche de Erbe	Manico portaelettrodi smartPen con due tasti, per elettrodi da 4 mm, con spina da Erbe
80-510-04-04	2	Electrode lancette	Elettrodo a lancetta
80-511-04-04	2	Electrode lancette, coudée	Elettrodo a lancetta, angolato
80-515-04-04	2	Electrode couteau	Elettrodo a bisturi
80-560-04-04	2	Electrode boule Ø 2 mm	Elettrodo a sfera Ø 2 mm
80-344-09-04	1	Electrodes neutres à usage unique type PCS DuoSafe UC = 50 pièces	Elettrodi neutri PCS DuoSafe monouso UV = 50 pezzi
80-294-40-04	1	Câble de raccordement pour électrodes neutres	Cavo di connessione per elettrodi neutri
80-924-16-04	2	Pinces bipolaires, droites, mousses	Pinze bipolari, strette, smusse
80-287-89-04	4	Câble de raccordement pour instruments bipolaires	Cavo di connessione per strumenti bipolari
80-975-23-04	2	marClamp® IQ, version courbe, 23 cm	marClamp® IQ, versione curva, 23 cm
80-570-23-04	2	marCut®, 23 cm	marCut®, 23 cm
80-505-00-04	1	Tampon de nettoyage pour électrodes, emballage stérile, UC = 100 pièces	Tampone di pulizia per elettrodi, imballaggio sterile, UV = 100 pezzi

maXium®-Beamer-Zubehörsätze für die Offene Chirurgie
 maXium® Beamer accessory sets for open surgery
 Juegos de accesorios maXium® Beamer para la cirugía abierta
 Jeux d'accessoires maXium® Beamer pour la chirurgie ouverte
 Serie di accessori maXium® Beamer per la chirurgia aperta

80-042-11-04		Satz Zubehör für maXium® m, bestehend aus:	Accessory set for maXium® m, consisting of:	Juego de accesorios para maXium® m, compuesto de:
80-181-52-04	1	Druckminderer (D, A, ...)	Pressure reducer (D, A, ...)	Manorreductor (D, A, ...)
80-830-01-04	1	SWAP-Mode-Doppelpedalfußschalter, 5 m Kabel, explosionsgeschützt, AP-geprüft, IP X8, eintauchbar	SWAP mode double-pedal foot switch, 5 m cable, explosion-proof, AP-tested, IP X8, immersible	Interruptor de pie de doble pedal con modo SWAP, cable 5 m, antiexplosivo, controlada su aptitud para anestésicos, IP X8, sumergible
80-830-02-04	1	Einpedalfußschalter, 5 m Kabel, explosionsgeschützt, AP-geprüft, IP X8, eintauchbar	Single-pedal foot switch, 5 m cable, explosion-proof, AP-tested, IP X8, immersible	Interruptor de pie de un pedal, cable 5 m, antiexplosivo, controlada su aptitud para anestésicos, IP X8, sumergible
80-260-50-04	1	Potentialausgleichskabel	Potential equalization cable	Cable de conexión equipotencial
80-181-02-04	2	Beamer-Handgriff	Beamer handle	Mango Beamer
80-181-10-04	2	Beamer-Elektrode	Beamer electrode	Electrodo Beamer
80-181-13-04	2	Beamer-Lanzettelektrode	Beamer lancet electrode	Electrodo de lanceta Beamer
80-181-15-04	2	Beamer-Nadelelektrode	Beamer needle electrode	Electrodo de aguja Beamer
80-344-09-04	1	PCS-DuoSafe-Einmal-Neutralelektroden, VE = 50 Stck.	PCS disposable neutral electrode, SU = 50/pack	Placas neutras desechables PCS DuoSafe UV = 50 piezas
80-294-40-04	1	Anschlusskabel für Neutralelektroden	Connection cable for neutral electrodes	Cable de conexión para placas neutras
80-924-16-04	2	Bipolare Pinzette, gerade, stumpf	Bipolar forceps, straight, blunt	Pinzas bipolares, rectas, romas
80-287-33-04	4	Anschlusskabel für bipolare Instrumente	Connection cable for bipolar instruments	Cable de conexión para instrumentos bipolares
		Optional:	Optional:	Opcional:
80-975-23-04	2	marClamp® IQ, gebogene Version, 23 cm	marClamp® IQ, curved version, 23 cm	marClamp® IQ, versión curva, 23 cm
80-570-23-04	2	marCut®, 23 cm	marCut®, 23 cm	marCut®, 23 cm

80-042-21-04		Satz Zubehör für maXium® i, bestehend aus:	Accessory set for maXium® i, consisting of:	Juego de accesorios para maXium® i, compuesto de:
80-181-53-04	1	Druckminderer (NL, DK, ...)	Pressure reducer (D, A, ...)	Manorreductor (NL, DK, ...)
80-830-01-04	1	SWAP-Mode-Doppelpedalfußschalter, 5 m Kabel, explosionsgeschützt, AP-geprüft, IP X8, eintauchbar	SWAP mode double-pedal foot switch, 5 m cable, explosion-proof, AP-tested, IP X8, immersible	Interruptor de pie de doble pedal con modo SWAP, cable 5 m, antiexplosivo, controlada su aptitud para anestésicos, IP X8, sumergible
80-830-02-04	1	Einpedalfußschalter, 5 m Kabel, explosionsgeschützt, AP-geprüft, IP X8, eintauchbar	Single-pedal foot switch, 5 m cable, explosion-proof, AP-tested, IP X8, immersible	Interruptor de pie de un pedal, cable 5 m, antiexplosivo, controlada su aptitud para anestésicos, IP X8, sumergible
80-260-50-04	1	Potentialausgleichskabel	Potential equalization cable	Cable de conexión equipotencial
80-181-02-04	2	Beamer-Handgriff	Beamer handle	Mango Beamer
80-181-10-04	2	Beamer-Elektrode	Beamer electrode	Electrodo Beamer
80-181-13-04	2	Beamer-Lanzettelektrode	Beamer lancet electrode	Electrodo de lanceta Beamer
80-181-15-04	2	Beamer-Nadelelektrode	Beamer needle electrode	Electrodo de aguja Beamer
80-344-09-04	1	PCS-DuoSafe-Einmal-Neutralelektroden, VE = 50 Stck.	PCS disposable neutral electrode, SU = 50/pack	Placas neutras desechables PCS DuoSafe UV = 50 piezas
80-294-44-04	1	Anschlusskabel für Neutralelektroden	Connection cable for neutral electrodes	Cable de conexión para placas neutras
80-924-16-04	2	Bipolare Pinzette, gerade, stumpf	Bipolar forceps, straight, blunt	Pinzas bipolares, rectas, romas
80-287-89-04	4	Anschlusskabel für bipolare Instrumente	Connection cable for bipolar instruments	Cable de conexión para instrumentos bipolares
		Optional:	Optional:	Opcional:
80-975-23-04	2	marClamp® IQ, gebogene Version, 23 cm	marClamp® IQ, curved version, 23 cm	marClamp® IQ, versión curva, 23 cm
80-570-23-04	2	marCut®, 23 cm	marCut®, 23 cm	marCut®, 23 cm



80-042-11-04		Lot d'accessoires pour maXium® m, composé de:	Serie di accessori per maXium® m, composta di:
80-181-52-04	1	Décompresseur (D, A, ...)	Riduttore di pressione (D, A, ...)
80-830-01-04	1	Interruteur à pédale double avec mode SWAP, câble 5 m, anti-explosif, catégorie AP, IP X8, immergeable	Interruttore a pedale doppio con modo SWAP, cavo 5 m, anti-deflagrante, testato AP, IP X8, immergibile
80-830-02-04	1	Interruteur à une pédale, câble 5 m, anti-explosif, catégorie AP, IP X8, immergeable	Interruttore monopedale, cavo 5 m, anti-deflagrante, testato AP, IP X8, immergibile
80-260-50-04	1	Câble de compensation de potentiel	Cavo per collegamento equipotenziale
80-181-02-04	2	Manche Beamer	Manico Beamer
80-181-10-04	2	Electrode Beamer	Elettrodo Beamer
80-181-13-04	2	Electrode lancette Beamer	Elettrodo a lancetta Beamer
80-181-15-04	2	Electrode aiguille Beamer	Elettrodo ad ago Beamer
80-344-09-04	1	Electrodes neutres à usage unique type PCS DuoSafe UC = 50 pièces	Elettrodi neutri PCS DuoSafe monouso UV = 50 pezzi
80-294-40-04	1	Câble de raccordement pour électrodes neutres	Cavo di connessione per elettrodi neutri
80-924-16-04	2	Pinces bipolaires, droites, mousses	Pinze bipolari, strette, smusse
80-287-33-04	4	Câble de raccordement pour instruments bipolaires	Cavo di connessione per strumenti bipolari
		En option:	Opzioni:
80-975-23-04	2	marClamp® IQ, version courbe, 23 cm	marClamp® IQ, versione curva, 23 cm
80-570-23-04	2	marCut®, 23 cm	marCut®, 23 cm

80-042-21-04		Lot d'accessoires pour maXium® i, composé de:	Serie di accessori per maXium® i, composta di:
80-181-52-04	1	Décompresseur (NL, DK, ...)	Riduttore di pressione (NL, DK, ...)
80-830-01-04	1	Interruteur à pédale double avec mode SWAP, câble 5 m, anti-explosif, catégorie AP, IP X8, immergeable	Interruttore a pedale doppio con modo SWAP, cavo 5 m, anti-deflagrante, testato AP, IP X8, immergibile
80-830-02-04	1	Interruteur à une pédale, câble 5 m, anti-explosif, catégorie AP, IP X8, immergeable	Interruttore monopedale, cavo 5 m, anti-deflagrante, testato AP, IP X8, immergibile
80-260-50-04	1	Câble de compensation de potentiel	Cavo per collegamento equipotenziale
80-181-02-04	2	Manche Beamer	Manico Beamer
80-181-10-04	2	Electrode Beamer	Elettrodo Beamer
80-181-13-04	2	Electrode lancette Beamer	Elettrodo a lancetta Beamer
80-181-15-04	2	Electrode aiguille Beamer	Elettrodo ad ago Beamer
80-344-09-04	1	Electrodes neutres à usage unique type PCS DuoSafe UC = 50 pièces	Elettrodi neutri PCS DuoSafe monouso UV = 50 pezzi
80-294-44-04	1	Câble de raccordement pour électrodes neutres	Cavo di connessione per elettrodi neutri
80-924-16-04	2	Pinces bipolaires, droites, mousses	Pinze bipolari, strette, smusse
80-287-89-04	4	Câble de raccordement pour instruments bipolaires	Cavo di connessione per strumenti bipolari
		En option:	Opzioni:
80-975-23-04	2	marClamp® IQ, version courbe, 23 cm	marClamp® IQ, versione curva, 23 cm
80-570-23-04	2	marCut®, 23 cm	marCut®, 23 cm

maXium®-Beamer-Zubehörsätze für die Offene Chirurgie
 maXium® Beamer accessory sets for open surgery
 Juegos de accesorios maXium® Beamer para la cirugía abierta
 Jeux d'accessoires maXium® Beamer pour la chirurgie ouverte
 Serie di accessori maXium® Beamer per la chirurgia aperta

80-042-41-04		Satz Zubehör für maXium® e, bestehend aus:	Accessory set for maXium® e, consisting of:	Juego de accesorios para maXium® e, compuesto de:
80-181-55-04	1	Druckminderer (UK ...)	Pressure reducer (UK ...)	Manorreductor (UK ...)
80-830-01-04	1	SWAP-Mode-Doppelpedalfußschalter, 5 m Kabel, explosionsgeschützt, AP-geprüft, IP X8, eintauchbar	SWAP mode double-pedal foot switch, 5 m cable, explosion-proof, AP-tested, IP X8, immersible	Interruptor de pie de doble pedal con modo SWAP, cable 5 m, antiexplosivo, controlada su aptitud para anestésicos, IP X8, sumergible
80-830-02-04	1	Einpedalfußschalter, 5 m Kabel, explosionsgeschützt, AP-geprüft, IP X8, eintauchbar	Single-pedal foot switch, 5 m cable, explosion-proof, AP-tested, IP X8, immersible	Interruptor de pie de un pedal, cable 5 m, antiexplosivo, controlada su aptitud para anestésicos, IP X8, sumergible
80-260-50-04	1	Potentialausgleichskabel	Potential equalization cable	Cable de conexión equipotencial
80-181-02-04	2	Beamer-Handgriff	Beamer handle	Mango Beamer
80-181-10-04	2	Beamer-Elektrode	Beamer electrode	Electrodo Beamer
80-181-13-04	2	Beamer-Lanzettelektrode	Beamer lancet electrode	Electrodo de lanceta Beamer
80-181-15-04	2	Beamer-Nadelelektrode	Beamer needle electrode	Electrodo de aguja Beamer
80-344-09-04	1	PCS-DuoSafe-Einmal-Neutralelektroden, VE = 50 Stck.	PCS disposable neutral electrode, SU = 50/pack	Placas neutras desechables PCS DuoSafe UV = 50 piezas
80-294-40-04	1	Anschlusskabel für Neutralelektroden	Connection cable for neutral electrodes	Cable de conexión para placas neutras
80-924-16-04	2	Bipolare Pinzette, gerade, stumpf	Bipolar forceps, straight, blunt	Pinzas bipolares, rectas, romas
80-287-89-04	4	Anschlusskabel für bipolare Instrumente	Connection cable for bipolar instruments	Cable de conexión para instrumentos bipolares
		Optional:	Optional:	Opcional:
80-975-23-04	2	marClamp® IQ, gebogene Version, 23 cm	marClamp® IQ, curved version, 23 cm	marClamp® IQ, versión curva, 23 cm
80-570-23-04	2	marCut®, 23 cm	marCut®, 23 cm	marCut®, 23 cm



80-042-41-04		Lot d'accessoires pour maXium® e, composé de:	Serie di accessori per maXium® e, composta di:
80-181-52-04	1	Décompresseur (UK ...)	Riduttore di pressione (UK ...)
80-830-01-04	1	Interrupteur à pédale double avec mode SWAP, câble 5 m, anti-explosif, catégorie AP, IP X8, immergeable	Interruttore a pedale doppio con modo SWAP, cavo 5 m, anti-deflagrante, testato AP, IP X8, immergibile
80-830-02-04	1	Interrupteur à une pédale, câble 5 m, anti-explosif, catégorie AP, IP X8, immergeable	Interruttore monopedale, cavo 5 m, anti-deflagrante, testato AP, IP X8, immergibile
80-260-50-04	1	Câble de compensation de potentiel	Cavo per collegamento equipotenziale
80-181-02-04	2	Manche Beamer	Manico Beamer
80-181-10-04	2	Electrode Beamer	Elettrodo Beamer
80-181-13-04	2	Electrode lancette Beamer	Elettrodo a lancetta Beamer
80-181-15-04	2	Electrode aiguille Beamer	Elettrodo ad ago Beamer
80-344-09-04	1	Electrodes neutres à usage unique type PCS DuoSafe UC = 50 pièces	Elettrodi neutri PCS DuoSafe monouso UV = 50 pezzi
80-294-40-04	1	Câble de raccordement pour électrodes neutres	Cavo di connessione per elettrodi neutri
80-924-16-04	2	Pinces bipolaires, droites, mousses	Pinze bipolari, strette, smusse
80-287-89-04	4	Câble de raccordement pour instruments bipolaires	Cavo di connessione per strumenti bipolari
		En option:	Opzioni:
80-975-23-04	2	marClamp® IQ, version courbe, 23 cm	marClamp® IQ, versione curva, 23 cm
80-570-23-04	2	marCut®, 23 cm	marCut®, 23 cm

maXium®-Beamer-Zubehörsätze für die Endoskopische Chirurgie
 maXium® Beamer accessory sets for endoscopic surgery
 Juegos de accesorios maXium® Beamer para la cirugía endoscópica
 Jeux d'accessoires maXium® Beamer pour la chirurgie endoscopique
 Serie di accessori maXium® Beamer per la chirurgia endoscopica

80-042-12-04		Satz Zubehör für maXium® m, bestehend aus:	Accessory set for maXium® m, consisting of:	Juego de accesorios para maXium® m, compuesto de:
80-181-52-04	1	Druckminderer (D, A, ...)	Pressure reducer (D, A, ...)	Manorreductor (D, A, ...)
80-830-02-04	1	Einpedalfußschalter, 5 m Kabel, explosionsgeschützt, AP-geprüft, IP X8, eintauchbar	Single-pedal foot switch, 5 m cable, explosion-proof, AP-tested, IP X8, immersible	Interrupor de pie de un pedal, cable 5 m, antiexplosivo, controlada su aptitud para anestésicos, IP X8, sumergible
80-260-50-04	1	Potentialausgleichskabel	Potential equalization cable	Cable de conexión equipotencial
80-181-30-04	2	Beamer-Anschlusskabel	Beamer connection cable	Cable de conexión Beamer
80-181-24-04	2	GIT-Sonde (Ø 3,2 mm)	GIT probe (Ø 3.2 mm)	Sonda GIT (Ø 3,2 mm)
80-181-23-04	2	GIT-Sonde (Ø 2,3 mm)	GIT probe (Ø 2.3 mm)	Sonda GIT (Ø 2,3 mm)
80-181-25-04	2	TBS-Sonde (Ø 1,5 mm)	TBS probe (Ø 1.5 mm)	Sonda TBS (Ø 1,5 mm)
80-344-09-04	1	PCS-DuoSafe-Einmal-Neutralelektroden, VE = 50 Stck.	Disposable DuoSafe neutral electrodes, SU = 50/pack	Placas neutras desechables PCS DuoSafe, UV = 50 piezas
80-294-40-04	1	Anschlusskabel für Neutralelektroden	Connection cable for neutral electrodes	Cable de conexión para placas neutras
80-924-16-04	2	Bipolare Pinzette, gerade, stumpf	Bipolar forceps, straight, blunt	Pinzas bipolares, rectas, romas
80-287-33-04	4	Anschlusskabel für bipolare Instrumente	Connection cable for bipolar instruments	Cable de conexión para instrumentos bipolares
80-289-40-04	2	Olympus-Anschlusskabel	Olympus connection cable	Cable de conexión Olympus

80-042-22-04		Satz Zubehör für maXium® i, bestehend aus:	Accessory set for maXium® i, consisting of:	Juego de accesorios para maXium® i, compuesto de:
80-181-53-04	1	Druckminderer (NL, DK, ...)	Pressure reducer (NL, DK, ...)	Manorreductor (NL, DK, ...)
80-830-02-04	1	Einpedalfußschalter, 5 m Kabel, explosionsgeschützt, AP-geprüft, IP X8, eintauchbar	Single-pedal foot switch, 5 m cable, explosion-proof, AP-tested, IP X8, immersible	Interrupor de pie de un pedal, cable 5 m, antiexplosivo, controlada su aptitud para anestésicos, IP X8, sumergible
80-260-50-04	1	Potentialausgleichskabel	Potential equalization cable	Cable de conexión equipotencial
80-181-30-04	2	Beamer-Anschlusskabel	Beamer connection cable	Cable de conexión Beamer
80-181-24-04	2	GIT-Sonde (Ø 3,2 mm)	GIT probe (Ø 3.2 mm)	Sonda GIT (Ø 3,2 mm)
80-181-23-04	2	GIT-Sonde (Ø 2,3 mm)	GIT probe (Ø 2.3 mm)	Sonda GIT (Ø 2,3 mm)
80-181-25-04	2	TBS-Sonde (Ø 1,5 mm)	TBS probe (Ø 1.5 mm)	Sonda TBS (Ø 1,5 mm)
80-344-09-04	1	PCS-DuoSafe-Einmal-Neutralelektroden, VE = 50 Stck.	Disposable DuoSafe neutral electrodes, SU = 50/pack	Placas neutras desechables PCS DuoSafe, UV = 50 piezas
80-294-44-04	1	Anschlusskabel für Neutralelektroden	Connection cable for neutral electrodes	Cable de conexión para placas neutras
80-924-16-04	2	Bipolare Pinzette, gerade, stumpf	Bipolar forceps, straight, blunt	Pinzas bipolares, rectas, romas
80-287-89-04	4	Anschlusskabel für bipolare Instrumente	Connection cable for bipolar instruments	Cable de conexión para instrumentos bipolares
80-289-40-04	2	Olympus-Anschlusskabel	Olympus connection cable	Cable de conexión Olympus

80-042-42-04		Satz Zubehör für maXium® e, bestehend aus:	Accessory set for maXium® e, consisting of:	Juego de accesorios para maXium® e, compuesto de:
80-181-55-04	1	Druckminderer (UK...)	Pressure reducer (UK...)	Manorreductor (UK...)
80-830-02-04	1	Einpedalfußschalter, 5 m Kabel, explosionsgeschützt, AP-geprüft, IP X8, eintauchbar	Single-pedal foot switch, 5 m cable, explosion-proof, AP-tested, IP X8, immersible	Interrupor de pie de un pedal, cable 5 m, antiexplosivo, controlada su aptitud para anestésicos, IP X8, sumergible
80-260-50-04	1	Potentialausgleichskabel	Potential equalization cable	Cable de conexión equipotencial
80-181-30-04	2	Beamer-Anschlusskabel	Beamer connection cable	Cable de conexión Beamer
80-181-24-04	2	GIT-Sonde (Ø 3,2 mm)	GIT probe (Ø 3.2 mm)	Sonda GIT (Ø 3,2 mm)
80-181-23-04	2	GIT-Sonde (Ø 2,3 mm)	GIT probe (Ø 2.3 mm)	Sonda GIT (Ø 2,3 mm)
80-181-25-04	2	TBS-Sonde (Ø 1,5 mm)	TBS probe (Ø 1.5 mm)	Sonda TBS (Ø 1,5 mm)
80-344-09-04	1	PCS-DuoSafe-Einmal-Neutralelektroden, VE = 50 Stck.	Disposable DuoSafe neutral electrodes, SU = 50/pack	Placas neutras desechables PCS DuoSafe, UV = 50 piezas
80-294-40-04	1	Anschlusskabel für Neutralelektroden	Connection cable for neutral electrodes	Cable de conexión para placas neutras
80-924-16-04	2	Bipolare Pinzette, gerade, stumpf	Bipolar forceps, straight, blunt	Pinzas bipolares, rectas, romas
80-287-89-04	4	Anschlusskabel für bipolare Instrumente	Connection cable for bipolar instruments	Cable de conexión para instrumentos bipolares
80-289-40-04	2	Olympus-Anschlusskabel	Olympus connection cable	Cable de conexión Olympus



80-042-12-04		Lot d'accessoires pour maXium® m, composé de:	Serie di accessori per maXium® m, composta di:
80-181-52-04	1	Décompresseur (D, A, ...)	Riduttore di pressione (D, A, ...)
80-830-02-04	1	Interrupteur à une pédale, câble 5 m, anti-explosif, catégorie AP, IP X8, immergeable	Interruttore monopedale, cavo 5 m, anti-deflagrante, testato AP, IP X8, immergibile
80-260-50-04	1	Câble de compensation de potentiel	Cavo per collegamento equipotenziale
80-181-30-04	2	Câble de raccordement Beamer	Cavo di connessione Beamer
80-181-24-04	2	Sonde GIT (Ø 3,2 mm)	Sonda GIT (Ø 3,2 mm)
80-181-23-04	2	Sonde GIT (Ø 2,3 mm)	Sonda GIT (Ø 2,3 mm)
80-181-25-04	2	Sonde TBS (Ø 1,5 mm)	Sonda TBS (Ø 1,5 mm)
80-344-09-04	1	Electrodes neutres à usage unique type PCS DuoSafe, UC = 50 pièces	Elettrodi neutri PCS DuoSafe monouso UV = 50 pezzi
80-294-40-04	1	Câble de raccordement pour électrodes neutres	Cavo di connessione per elettrodi neutri
80-924-16-04	2	Pinces bipolaires, droites, mousses	Pinze bipolari, strette, smusse
80-287-33-04	4	Câble de raccordement pour instruments bipolaires	Cavo di connessione per strumenti bipolari
80-289-40-04	2	Câble de raccordement Olympus	Cavo di connessione Olympus

80-042-22-04		Lot d'accessoires pour maXium® i, composé de:	Serie di accessori per maXium® i, composta di:
80-181-53-04	1	Décompresseur (NL, DK, ...)	Riduttore di pressione (NL, DK, ...)
80-830-02-04	1	Interrupteur à une pédale, câble 5 m, anti-explosif, catégorie AP, IP X8, immergeable	Interruttore monopedale, cavo 5 m, anti-deflagrante, testato AP, IP X8, immergibile
80-260-50-04	1	Câble de compensation de potentiel	Cavo per collegamento equipotenziale
80-181-30-04	2	Câble de raccordement Beamer	Cavo di connessione Beamer
80-181-24-04	2	Sonde GIT (Ø 3,2 mm)	Sonda GIT (Ø 3,2 mm)
80-181-23-04	2	Sonde GIT (Ø 2,3 mm)	Sonda GIT (Ø 2,3 mm)
80-181-25-04	2	Sonde TBS (Ø 1,5 mm)	Sonda TBS (Ø 1,5 mm)
80-344-09-04	1	Electrodes neutres à usage unique type PCS DuoSafe UC = 50 pièces	Elettrodi neutri PCS DuoSafe monouso UV = 50 pezzi
80-294-44-04	1	Câble de raccordement pour électrodes neutres	Cavo di connessione per elettrodi neutri
80-924-16-04	2	Pinces bipolaires, droites, mousses	Pinze bipolari, strette, smusse
80-287-89-04	4	Câble de raccordement pour instruments bipolaires	Cavo di connessione per strumenti bipolari
80-289-40-04	2	Câble de raccordement Olympus	Cavo di connessione Olympus

80-042-42-04		Lot d'accessoires pour maXium® e, composé de:	Serie di accessori per maXium® e, composta di:
80-181-55-04	1	Décompresseur (UK...)	Riduttore di pressione (UK...)
80-830-02-04	1	Interrupteur à une pédale, câble 5 m, anti-explosif, catégorie AP, IP X8, immergeable	Interruttore monopedale, cavo 5 m, anti-deflagrante, testato AP, IP X8, immergibile
80-260-50-04	1	Câble de compensation de potentiel	Cavo per collegamento equipotenziale
80-181-30-04	2	Câble de raccordement Beamer	Cavo di connessione Beamer
80-181-24-04	2	Sonde GIT (Ø 3,2 mm)	Sonda GIT (Ø 3,2 mm)
80-181-23-04	2	Sonde GIT (Ø 2,3 mm)	Sonda GIT (Ø 2,3 mm)
80-181-25-04	2	Sonde TBS (Ø 1,5 mm)	Sonda TBS (Ø 1,5 mm)
80-344-09-04	1	Electrodes neutres à usage unique type PCS DuoSafe UC = 50 pièces	Elettrodi neutri PCS DuoSafe monouso UV = 50 pezzi
80-294-40-04	1	Câble de raccordement pour électrodes neutres	Cavo di connessione per elettrodi neutri
80-924-16-04	2	Pinces bipolaires, droites, mousses	Pinze bipolari, strette, smusse
80-287-89-04	4	Câble de raccordement pour instruments bipolaires	Cavo di connessione per strumenti bipolari
80-289-40-04	2	Câble de raccordement Olympus	Cavo di connessione Olympus

80-107-00-04		Zubehörsatz, Handaktivierung für MD 62, bestehend aus:	Accessory set for MD 62 for hand switch operation, consisting of:	Juego de accesorios MD 62 con interruptor digital, compuesto de:
80-214-13-04	1	smartPen Elektroden-Handgriff mit einer Taste für 1,6-mm-Elektroden, mit KLS Martin-Stecker	smartPen electrode handle with one pushbutton, for 1.6-mm electrodes, with KLS Martin plug	Mango porta-electrodos smartPen con una tecla, para electrodos 1,6 mm, con clavija de KLS Martin
80-444-08-01	1	Elektroden-Ständer für 8 Dentalelektroden	Electrode box for 8 dental electrodes	Caja para 8 electrodos dentales
80-461-01-04	1	Nadelelektrode	Needle electrode	Electrodo de aguja
80-461-02-04	1	Nadelelektrode	Needle electrode	Electrodo de aguja
80-461-12-04	1	Schlingenelektrode	Loop electrode	Electrodo de asa de alambre
80-461-14-04	1	Schlingenelektrode	Loop electrode	Electrodo de asa de alambre
80-461-15-04	1	Schlingenelektrode	Loop electrode	Electrodo de asa de alambre
80-461-31-04	1	Koagulations-Nadelelektrode	Coagulation needle electrode	Electrodo de aguja, para la coagulación
80-461-34-04	1	Koagulations-Kugelelektrode	Coagulation ball electrode	Electrodo de bola, para la coagulación
80-310-04-04	1	Handzylinder-Neutralelektrode mit 4 m Kabel	Hand cylinder neutral electrode with connection cable of 4 m	Placa neutra en forma de cilindro con cable de conexión de 4 m
80-505-00-04	1	Reinigungspad für Elektroden, steril verpackt, VE = 100 Stck.	Cleaning pad for electrodes, sterile packed, SU = 100/pack	Almohadilla de limpieza para electrodos, embalado estéril, UV = 100 piezas

80-106-01-04		Zubehörsatz, Fußaktivierung für MD 62, bestehend aus:	Accessory set for MD 62 for foot switch operation, consisting of:	Juego de accesorios MD 62 con interruptor de pedal, compuesto de:
80-214-12-04	1	smartPen Elektroden-Handgriff ohne Tasten für 1,6-mm-Elektroden, mit KLS Martin-Stecker	smartPen electrode handle without pushbutton, for 1.6-mm electrodes, with KLS Martin plug	Mango porta-electrodos smartPen sin teclas, para electrodos 1,6 mm, con clavija de KLS Martin
80-444-08-01	1	Elektroden-Ständer für 8 Dentalelektroden	Electrode box for 8 dental electrodes	Caja para 8 electrodos dentales
80-461-01-04	1	Nadelelektrode	Needle electrode	Electrodo de aguja
80-461-02-04	1	Nadelelektrode	Needle electrode	Electrodo de aguja
80-461-12-04	1	Schlingenelektrode	Loop electrode	Electrodo de asa de alambre
80-461-14-04	1	Schlingenelektrode	Loop electrode	Electrodo de asa de alambre
80-461-15-04	1	Schlingenelektrode	Loop electrode	Electrodo de asa de alambre
80-461-31-04	1	Koagulations-Nadelelektrode	Coagulation needle electrode	Electrodo de aguja, para la coagulación
80-461-34-04	1	Koagulations-Kugelelektrode	Coagulation ball electrode	Electrodo de bola, para la coagulación
80-812-10-04	1	Einpedal-Fußschalter, Air, 3 m Kabel	Single-pedal foot switch, Air, with connection cable of 3 m	Interruptor de pedal, Air, cable de conexión de 3 m
80-310-04-04	1	Handzylinder-Neutralelektrode mit 4 m Kabel	Hand cylinder neutral electrode with connection cable of 4 m	Placa neutra en forma de cilindro con cable de conexión de 4 m
80-505-00-04	1	Reinigungspad für Elektroden, steril verpackt, VE = 100 Stck.	Cleaning pad for electrodes, sterile packed, SU = 100/pack	Almohadilla de limpieza para electrodos, embalado estéril, UV = 100 piezas



80-107-00-04		Lot d'accessoires MD 62 pour commande digitale, composé de:	Serie di accessori standard MD 62, per attivazione a mano, composta di:
80-214-13-04	1	Manche porte-électrode smartPen avec un interrupteur digital, pour electrodes de 1,6 mm, avec fiche de KLS Martin	Manico portaelettrodi smartPen con un tasto, per elettrodi da 4 mm, con spina da KLS Martin
80-444-08-01	1	Boîte pour 8 électrodes dentaires	Supporto per 8 elettrodi dentali in scatola
80-461-01-04	1	Electrode aiguille	Elettrodo ad ago
80-461-02-04	1	Electrode aiguille	Elettrodo ad ago
80-461-12-04	1	Electrode anse	Elettrodo ad ansa
80-461-14-04	1	Electrode anse	Elettrodo ad ansa
80-461-15-04	1	Electrode anse	Elettrodo ad ansa
80-461-31-04	1	Electrode aiguille pour la coagulation	Elettrodo ad ago per coagulazione
80-461-34-04	1	Electrode boule pour la coagulation	Elettrodo a sfera per coagulazione
80-310-04-04	1	Electrode neutre en forme de cylindre avec câble de raccordement de 4 m	Elettrodo neutro a forma cilindrica con cavo di connessione da 4 m
80-505-00-04	1	Tampon de nettoyage pour électrodes, emballage stérile, UC = 100 pièces	Tampone di pulizia per elettrodi, imballaggio sterile, UV = 100 pezzi

80-106-01-04		Lot d'accessoires MD 62 pour commande par pédale, composé de:	Serie di accessori standard MD 62, per attivazione a pedale, composta di:
80-214-12-04	1	Manche porte-électrode smartPen sans interrupteur, pour electrodes de 1,6 mm, avec fiche de KLS Martin	Manico portaelettrodi smartPen senza tasti, per elettrodi da 1,6mm, con spina da KLS Martin
80-444-08-01	1	Boîte pour 8 électrodes dentaires	Supporto per 8 elettrodi dentali in scatola
80-461-01-04	1	Electrode aiguille	Elettrodo ad ago
80-461-02-04	1	Electrode aiguille	Elettrodo ad ago
80-461-12-04	1	Electrode anse	Elettrodo ad ansa
80-461-14-04	1	Electrode anse	Elettrodo ad ansa
80-461-15-04	1	Electrode anse	Elettrodo ad ansa
80-461-31-04	1	Electrode aiguille pour la coagulation	Elettrodo ad ago per coagulazione
80-461-34-04	1	Electrode boule pour la coagulation	Elettrodo a sfera per coagulazione
80-812-10-04	1	Interrupteur à pédale, Air, avec câble de raccordement de 3 m	Interruttore con 1 pedale, Air, con cavo di connessione di 3 m
80-310-04-04	1	Electrode neutre en forme de cylindre avec câble de raccordement de 4 m	Elettrodo neutro a forma cilindrica con cavo di connessione da 4 m
80-505-00-04	1	Tampon de nettoyage pour électrodes, emballage stérile, UC = 100 pièces	Tampone di pulizia per elettrodi, imballaggio sterile, UV = 100 pezzi

80-108-03-04		Großer Zubehörsatz monopolar, Handaktivierung für miniCutter, bestehend aus:	Accessory set monopolar for miniCutter for hand switch operation, large, consisting of:	Juego de accesorios monopolares miniCutter con interruptor digital, grande, compuesto de:
80-217-05-04	1	smartPen Elektroden-Handgriff mit einer Taste für 4-mm-Elektroden, mit KLS Martin-Stecker	smartPen electrode handle with one pushbutton, for 4-mm electrodes, with KLS Martin plug	Mango porta-electrodos smartPen con una tecla, para electrodos 4 mm, con clavija de KLS Martin
80-332-03-04	1	Gummi-Neutralelektrode 8 x 16 cm, 4 m Kabel	Rubber neutral electrode, 8 x 16 cm, with connection cable of 4 m	Placa neutra de goma, 8 x 16 cm, cable de conexión de 4 m
80-370-50-04	1	Gummibinde, gelocht, 50 cm	Rubber band, with holes, 50 cm	Cinta de goma, perforada, 50 cm
80-371-01-04	1	Knopf für Gummibinde	Button for rubber band	Botón para la cinta de goma
80-408-00-04	1	Elektroden-Ständer für 8 Elektroden	Electrode box for 8 electrodes	Caja para 8 electrodos
80-505-00-04	1	Reinigungspad für Elektroden, steril verpackt, VE = 100 Stck.	Cleaning pad for electrodes, sterile packed, SU = 100/pack	Almohadilla de limpieza para electrodos, embalado estéril, UV = 100 piezas
80-510-04-04	1	Lanzettelektrode, gerade	Lancet electrode, straight	Electrodo de lanceta, recto
80-515-04-04	1	Messerelektrode	Knife electrode	Electrodo de cuchillo
80-520-04-04	1	Nadelelektrode	Needle electrode	Electrodo de aguja
80-540-04-04	1	Drahtschlingenelektrode, Ø 5 mm	Wire loop electrode, Ø 5 mm	Electrodo de asa de alambre, Ø 5 mm
80-542-04-04	1	Drahtschlingenelektrode, Ø 10 mm	Wire loop electrode, Ø 10 mm	Electrodo de asa de alambre Ø 10 mm
80-560-04-04	1	Kugelelektrode, Ø 2 mm	Ball electrode, Ø 2 mm	Electrodo de bola, Ø 2 mm
80-562-04-04	1	Kugelelektrode, Ø 4 mm	Ball electrode, Ø 4 mm	Electrodo de bola, Ø 4 mm

80-108-04-04		Großer Zubehörsatz monopolar, Fußaktivierung für miniCutter, bestehend aus:	Accessory set monopolar for miniCutter for foot switch operation, large, consisting of:	Juego de accesorios monopolares miniCutter con interruptor de pedal, grande, compuesto de:
80-220-02-04	1	smartPen Elektroden-Handgriff ohne Tasten für 4-mm-Elektroden, mit KLS Martin-Stecker	smartPen electrode handle without pushbutton, for 4-mm electrodes, with KLS Martin plug	Mango porta-electrodos smartPen sin tecla, para electrodos 4 mm, con clavija de KLS Martin
80-332-03-04	1	Gummi-Neutralelektrode 8 x 16 cm, 4 m Kabel	Rubber neutral electrode, 8 x 16 cm, with connection cable of 4 m	Placa neutra de goma, 8 x 16 cm, cable de conexión de 4 m
80-370-50-04	1	Gummibinde, gelocht, 50 cm	Rubber band, with holes, 50 cm	Cinta de goma, perforada, 50 cm
80-371-01-04	1	Knopf für Gummibinde	Button for rubber band	Botón para la cinta de goma
80-408-00-01	1	Elektroden-Ständer für 8 Elektroden	Electrode box for 8 electrodes	Caja para 8 electrodos
80-505-00-04	1	Reinigungspad für Elektroden, steril verpackt, VE = 100 Stck.	Cleaning pad for electrodes, sterile packed, SU = 100/pack	Almohadilla de limpieza para electrodos, embalado estéril, UV = 100 piezas
80-510-04-04	1	Lanzettelektrode, gerade	Lancet electrode, straight	Electrodo de lanceta, recto
80-515-04-04	1	Messerelektrode	Knife electrode	Electrodo de cuchillo
80-520-04-04	1	Nadelelektrode	Needle electrode	Electrodo de aguja
80-540-04-04	1	Drahtschlingenelektrode, Ø 5 mm	Wire loop electrode, Ø 5 mm	Electrodo de asa de alambre, Ø 5 mm
80-542-04-04	1	Drahtschlingenelektrode, Ø 10 mm	Wire loop electrode, Ø 10 mm	Electrodo de asa de alambre Ø 10 mm
80-560-04-04	1	Kugelelektrode, Ø 2 mm	Ball electrode, Ø 2 mm	Electrodo de bola, Ø 2 mm
80-562-04-04	1	Kugelelektrode, Ø 4 mm	Ball electrode, Ø 4 mm	Electrodo de bola, Ø 4 mm
80-811-50-04	1	Einpedal-Fußschalter, AP-geprüft, 5 m Kabel	Foot switch, anti-explosive, with connection cable of 5 m	Interruptor de pedal, anti-explosivo, con cable de conexión de 5 m

80-108-05-04		Kleiner Zubehörsatz monopolar, Handaktivierung für miniCutter, bestehend aus:	Accessory set monopolar for miniCutter for hand switch operation, small, consisting of:	Juego de accesorios monopolares miniCutter con interruptor digital, pequeño, compuesto de:
80-217-05-04	1	smartPen Elektroden-Handgriff mit einer Taste für 4-mm-Elektroden, mit KLS Martin-Stecker	smartPen electrode handle with one pushbutton, for 4-mm electrodes, with KLS Martin plug	Mango porta-electrodos smartPen con una tecla, para electrodos 4 mm, con clavija de KLS Martin
80-332-03-04	1	Gummi-Neutralelektrode 8 x 16 cm, 4 m Kabel	Rubber neutral electrode, 8 x 16 cm, with connection cable of 4 m	placa neutra de goma, 8 x 16 cm, cable de conexión de 4 m
80-372-00-04	1	Textilband mit Klettverschluss, 90 cm	Textile band with velcro strap, 90 cm	Tira auto-adhesiva, 90 cm
80-505-00-04	1	Reinigungspad für Elektroden, steril verpackt, VE = 100 Stck.	Cleaning pad for electrodes, sterile packed, SU = 100/pack	Almohadilla de limpieza para electrodos, embalado estéril, UV = 100 piezas
80-511-04-04	1	Lanzettelektrode, abgewinkelt	Lancet electrode, angled	Electrodo de lanceta, acodado
80-515-04-04	1	Messerelektrode	Knife electrode	Electrodo de cuchillo
80-520-04-04	1	Nadelelektrode	Needle electrode	Electrodo de aguja
80-562-04-04	1	Kugelelektrode, Ø 4 mm	Ball electrode, Ø 4 mm	Electrodo de bola, Ø 4 mm

80-108-03-04		Grand lot d'accessoires monopolaires miniCutter pour commande digitale, composé de:	Serie grande di accessori monopolari standard miniCutter, per attivazione a mano, composta di:
80-217-05-04	1	Manche porte-électrode smartPen avec un interrupteur digital, pour electrodes de 4 mm, avec fiche de KLS Martin	Manico portaelettrodi smartPen con una tasto, per elettrodi da 4 mm, con spina da KLS Martin
80-332-03-04	1	Electrode neutre en caoutchouc, 8 x 16 cm, avec câble de raccordement de 4 m	Elettrodo neutro di gomma, 8 x 16 cm, cavo di connessione di 4 m
80-370-50-04	1	Bande caoutchouc, perforée, 50 cm	Nastro di gomma, perforato, 50 cm
80-371-01-04	1	Bouton pour bande caoutchouc	Bottone per nastro di gomma
80-408-00-04	1	Boîte pour 8 électrodes	Supporto per 8 elettrodi in scatola
80-505-00-04	1	Tampon de nettoyage pour électrodes, emballage stérile, UC = 100 pièces	Tampone di pulizia per elettrodi, imballaggio sterile, UV = 100 pezzi
80-510-04-04	1	Electrode lancette, droite	Elettrodo a lancetta, retto
80-515-04-04	1	Electrode couteau	Elettrodo a bisturi
80-520-04-04	1	Electrode aiguille	Elettrodo ad ago
80-540-04-04	1	Electrode anse en fil, Ø 5 mm	Elettrodo ad ansa, Ø 5 mm
80-542-04-04	1	Electrode anse en fil, Ø 10 mm	Elettrodo ad ansa, Ø 10 mm
80-560-04-04	1	Electrode boule, Ø 2 mm	Elettrodo a sfera, Ø 2 mm
80-562-04-04	1	Electrode boule, Ø 4 mm	Elettrodo a sfera, Ø 4 mm

80-108-04-04		Grand lot d'accessoires monopolaires miniCutter pour commande par pédale, composé de:	Serie grande di accessori monopolari standard miniCutter, per attivazione a pedale, composta di:
80-220-02-04	1	Manche porte-électrode smartPen sans interrupteur, pour electrodes de 4 mm, avec fiche de KLS Martin	Manico portaelettrodi smartPen senza tasti, per elettrodi da 4 mm, con spina da KLS Martin
80-332-03-04	1	Electrode neutre en caoutchouc, 8 x 16 cm, avec câble de raccordement de 4 m	Elettrodo neutro di gomma, 8 x 16 cm, cavo di connessione di 4 m
80-370-50-04	1	Bande caoutchouc, perforée, 50 cm	Nastro di gomma, perforato, 50 cm
80-371-01-04	1	Bouton pour bande caoutchouc	Bottone per nastro di gomma
80-408-00-01	1	Boîte pour 8 électrodes	Supporto per 8 elettrodi in scatola
80-505-00-04	1	Tampon de nettoyage pour électrodes, emballage stérile, UC = 100 pièces	Tampone di pulizia per elettrodi, imballaggio sterile, UV = 100 pezzi
80-510-04-04	1	Electrode lancette, droite	Elettrodo a lancetta, retto
80-515-04-04	1	Electrode couteau	Elettrodo a bisturi
80-520-04-04	1	Electrode aiguille	Elettrodo ad ago
80-540-04-04	1	Electrode anse en fil, Ø 5 mm	Elettrodo ad ansa, Ø 5 mm
80-542-04-04	1	Electrode anse en fil, Ø 10 mm	Elettrodo ad ansa, Ø 10 mm
80-560-04-04	1	Electrode boule, Ø 2 mm	Elettrodo a sfera, Ø 2 mm
80-562-04-04	1	Electrode boule, Ø 4 mm	Elettrodo a sfera, Ø 4 mm
80-811-50-04	1	Interrupteur à pédale, anti-explosif avec câble de raccordement de 5 m	Interruttore a pedale, anti-deflagrante, con cavo di connessione di 5 m

80-108-05-04		Petit lot d'accessoires monopolaires miniCutter pour commande digitale, composé de:	Serie piccola di accessori monopolari standard miniCutter, per attivazione a mano, composta di:
80-217-05-04	1	Manche porte-électrode smartPen avec un interrupteur digital, pour electrodes de 4 mm, avec fiche de KLS Martin	Manico portaelettrodi smartPen con una tasto, per elettrodi da 4 mm, con spina da KLS Martin
80-332-03-04	1	Electrode neutre en caoutchouc, 8 x 16 cm, avec câble de raccordement de 4 m	Elettrodo neutro di gomma, 8 x 16 cm, cavo di connessione di 4 m
80-372-00-04	1	Bande auto-adhésive, 90 cm	Nastro tessile auto-adesivo, 90 cm
80-505-00-04	1	Tampon de nettoyage pour électrodes, emballage stérile, UC = 100 pièces	Tampone di pulizia per elettrodi, imballaggio sterile, UV = 100 pezzi
80-511-04-04	1	Electrode lancette, coudée	Elettrodo a lancetta, angolato
80-515-04-04	1	Electrode couteau	Elettrodo a bisturi
80-520-04-04	1	Electrode aiguille	Elettrodo ad ago
80-562-04-04	1	Electrode boule, Ø 4 mm	Elettrodo a sfera, Ø 4 mm

80-108-00-04		Großer Zubehörsatz monopolar, Handaktivierung für ME 102, bestehend aus:	Accessory set monopolar for ME 102 for hand switch operation, large, consisting of:	Juego de accesorios monopolares ME 102 con interruptor digital, grande, compuesto de:
80-217-13-04	1	smartPen Elektroden-Handgriff mit zwei Tasten für 4-mm-Elektroden, mit KLS Martin-Stecker	smartPen electrode handle with two pushbuttons, for 4-mm electrodes, with KLS Martin plug	Mango porta-electrodos smartPen con dos teclas, para electrodos 4 mm, con clavija de KLS Martin
80-332-03-04	1	Gummi-Neutralelektrode 8 x 16 cm, 4 m Kabel	Rubber neutral electrode, 8 x 16 cm, with connection cable of 4 m	Placa neutra de goma, 8 x 16 cm, cable de conexión de 4 m
80-370-50-04	1	Gummibinde, gelocht, 50 cm	Rubber band, with holes, 50 cm	Cinta de goma, perforada, 50 cm
80-371-01-04	1	Knopf für Gummibinde	Button for rubber band	Botón para la cinta de goma
80-408-00-04	1	Elektroden-Ständer für 8 Elektroden	Electrode box for 8 electrodes	Caja para 8 electrodos
80-505-00-04	1	Reinigungspad für Elektroden, steril verpackt, VE = 100 Stck.	Cleaning pad for electrodes, sterile packed, SU = 100/pack	Almohadilla de limpieza para electrodos, embalado estéril, UV = 100 piezas
80-510-04-04	1	Lanzettelektrode, gerade	Lancet electrode, straight	Electrodo de lanceta, recto
80-515-04-04	1	Messerelektrode	Knife electrode	Electrodo de cuchillo
80-520-04-04	1	Nadelelektrode	Needle electrode	Electrodo de aguja
80-540-04-04	1	Drahtschlingenelektrode, Ø 5 mm	Wire loop electrode, Ø 5 mm	Electrodo de asa de alambre, Ø 5 mm
80-542-04-04	1	Drahtschlingenelektrode, Ø 10 mm	Wire loop electrode, Ø 10 mm	Electrodo de asa de alambre, Ø 10 mm
80-560-04-04	1	Kugelelektrode, Ø 2 mm	Ball electrode, Ø 2 mm	Electrodo de bola, Ø 2 mm
80-562-04-04	1	Kugelelektrode, Ø 4 mm	Ball electrode, Ø 4 mm	Electrodo de bola, Ø 4 mm

80-108-01-04		Großer Zubehörsatz monopolar, Fußaktivierung für ME 102, bestehend aus:	Accessory set monopolar for ME 102 for foot switch operation, large, consisting of:	Juego de accesorios monopolares ME 102 con interruptor de pedal, grande, compuesto de:
80-220-02-04	1	smartPen Elektroden-Handgriff ohne Tasten für 4-mm-Elektroden, mit KLS Martin-Stecker	smartPen electrode handle without pushbuttons, for 4-mm electrodes, with KLS Martin plug	Mango porta-electrodos smartPen sin teclas, para electrodos 4 mm, con clavija de KLS Martin
80-332-03-04	1	Gummi-Neutralelektrode 8 x 16 cm, 4 m Kabel	Rubber neutral electrode, 8 x 16 cm, with connection cable of 4 m	Placa neutra de goma, 8 x 16 cm, cable de conexión de 4 m
80-370-50-04	1	Gummibinde, gelocht, 50 cm	Rubber band, with holes, 50 cm	Cinta de goma, perforada, 50 cm
80-371-01-04	1	Knopf für Gummibinde	Button for rubber band	Botón para la cinta de goma
80-408-00-01	1	Elektroden-Ständer für 8 Elektroden	Electrode box for 8 electrodes	Caja para 8 electrodos
80-505-00-04	1	Reinigungspad für Elektroden, steril verpackt, VE = 100 Stck.	Cleaning pad for electrodes, sterile packed, SU = 100/pack	Almohadilla de limpieza para electrodos, embalado estéril, UV = 100 piezas
80-510-04-04	1	Lanzettelektrode, gerade	Lancet electrode, straight	Electrodo de lanceta, recto
80-515-04-04	1	Messerelektrode	Knife electrode	Electrodo de cuchillo
80-520-04-04	1	Nadelelektrode	Needle electrode	Electrodo de aguja
80-540-04-04	1	Drahtschlingenelektrode, Ø 5 mm	Wire loop electrode, Ø 5 mm	Electrodo de asa de alambre, Ø 5 mm
80-542-04-04	1	Drahtschlingenelektrode, Ø 10 mm	Wire loop electrode, Ø 10 mm	Electrodo de asa de alambre, Ø 10 mm
80-560-04-04	1	Kugelelektrode, Ø 2 mm	Ball electrode, Ø 2 mm	Electrodo de bola, Ø 2 mm
80-562-04-04	1	Kugelelektrode, Ø 4 mm	Ball electrode, Ø 4 mm	Electrodo de bola, Ø 4 mm
80-823-02-04	1	Doppelpedal-Fußschalter, 5 m Kabel	Double-pedal foot switch, with connection cable of 5 m	Interruptor de pedal, anti-explosivo, con cable de conexión de 5 m

80-108-02-04		Kleiner Zubehörsatz monopolar, Handaktivierung für ME 102, bestehend aus:	Accessory set monopolar for ME 102 for hand switch operation, small, consisting of:	Juego de accesorios monopolares ME 102 con interruptor digital, pequeño, compuesto de:
80-217-05-04	1	smartPen Elektroden-Handgriff mit einer Taste für 4-mm-Elektroden, mit KLS Martin-Stecker	smartPen electrode handle with one pushbutton, for 4-mm electrodes, with KLS Martin plug	Mango porta-electrodos smartPen con una tecla, para electrodos 4 mm, con clavija de KLS Martin
80-332-03-04	1	Gummi-Neutralelektrode 8 x 16 cm, 4 m Kabel	Rubber neutral electrode, 8 x 16 cm, with connection cable of 4 m	Placa neutra de goma, 8 x 16 cm, cable de conexión de 4 m
80-372-00-04	1	Textilband mit Klettverschluss, 90 cm	Textile band with velcro strap, 90 cm	Tira auto-adhesiva, 90 cm
80-505-00-04	1	Reinigungspad für Elektroden, steril verpackt, VE = 100 Stck.	Cleaning pad for electrodes, sterile packed, SU = 100/pack	Almohadilla de limpieza para electrodos, embalado estéril, UV = 100 piezas
80-511-04-04	1	Lanzettelektrode, abgewinkelt	Lancet electrode, angled	Electrodo de lanceta, acodado
80-515-04-04	1	Messerelektrode	Knife electrode	Electrodo de cuchillo
80-520-04-04	1	Nadelelektrode	Needle electrode	Electrodo de aguja
80-562-04-04	1	Kugelelektrode, Ø 4 mm	Ball electrode, Ø 4 mm	Electrodo de bola, Ø 4 mm



80-108-00-04		Grand lot d'accessoires monopolaires ME 102 pour commande digitale, composé de:	Serie grande di accessori monopolari standard ME 102, per attivazione a mano, composta di:
80-217-13-04	1	Manche porte-électrode smartPen avec interrupteur digital double, pour électrodes de 4 mm, avec fiche de KLS Martin	Manico portaelettrodi smartPen con due tasti, per elettrodi da 4 mm, con spina da KLS Martin
80-332-03-04	1	Electrode neutre en caoutchouc, 8 x 16 cm, avec câble de raccordement de 4 m	Elettrodo neutro di gomma, 8 x 16 cm, cavo di connessione di 4 m
80-370-50-04	1	Bande caoutchouc, perforée, 50 cm	Nastro di gomma, perforato, 50 cm
80-371-01-04	1	Bouton pour bande caoutchouc	Bottone per nastro di gomma
80-408-00-04	1	Boîte pour 8 électrodes	Supporto per 8 elettrodi in scatola
80-505-00-04	1	Tampon de nettoyage pour électrodes, emballage stérile	Tampone di pulizia per elettrodi, imballaggio sterile, UV = 100 pezzi
80-510-04-04	1	Electrode lancette, droite	Elettrodo a lancetta, retto
80-515-04-04	1	Electrode couteau	Elettrodo a bisturi
80-520-04-04	1	Electrode aiguille	Elettrodo ad ago
80-540-04-04	1	Electrode anse en fil, Ø 5 mm	Elettrodo ad ansa, Ø 5 mm
80-542-04-04	1	Electrode anse en fil, Ø 0 mm	Elettrodo ad ansa, Ø 10 mm
80-560-04-04	1	Electrode boule, Ø 2 mm	Elettrodo a sfera, Ø 2 mm
80-562-04-04	1	Electrode boule, Ø 4 mm	Elettrodo a sfera, Ø 4 mm

80-108-01-04		Grand lot d'accessoires monopolaires ME 102 pour commande par pédale, composé de:	Serie grande di accessori monopolari standard ME 102, per attivazione a pedale, composta di:
80-220-02-04	1	Manche porte-électrode smartPen sans interrupteur digital double, pour électrodes de 4 mm, avec fiche de KLS Martin	Manico portaelettrodi smartPen senza tasti, per elettrodi da 4 mm, con spina da KLS Martin
80-332-03-04	1	Electrode neutre en caoutchouc, 8 x 16 cm, avec câble de raccordement de 4 m	Elettrodo neutro di gomma, 8 x 16 cm, cavo di connessione di 4 m
80-370-50-04	1	Bande caoutchouc, perforée, 50 cm	Nastro di gomma, perforato, 50 cm
80-371-01-04	1	Bouton pour bande caoutchouc	Bottone per nastro di gomma
80-408-00-01	1	Boîte pour 8 électrodes	Supporto per 8 elettrodi in scatola
80-505-00-04	1	Tampon de nettoyage pour électrodes, emballage stérile	Tampone di pulizia per elettrodi, imballaggio sterile, UV = 100 pezzi
80-510-04-04	1	Electrode lancette, droite	Elettrodo a lancetta, retto
80-515-04-04	1	Electrode couteau	Elettrodo a bisturi
80-520-04-04	1	Electrode aiguille	Elettrodo ad ago
80-540-04-04	1	Electrode anse en fil, Ø 5 mm	Elettrodo ad ansa, Ø 5 mm
80-542-04-04	1	Electrode anse en fil, Ø 10 mm	Elettrodo ad ansa, Ø 10 mm
80-560-04-04	1	Electrode boule, Ø 2 mm	Elettrodo a sfera, Ø 2 mm
80-562-04-04	1	Electrode boule, Ø 4 mm	Elettrodo a sfera, Ø 4 mm
80-823-02-04	1	Interrupteur à pédale double, avec câble de raccordement de 5 m	Interruttore a pedale doppio, con cavo di connessione di 5 m

80-108-02-04		Petit lot d'accessoires monopolaires ME 102 pour commande digitale, composé de:	Serie piccola di accessori monopolari standard ME 102, per attivazione a mano, composta di:
80-217-05-04	1	Manche porte-électrode smartPen avec un interrupteur digital, pour électrodes de 4 mm, avec fiche de KLS Martin	Manico portaelettrodi smartPen con una tasto, per elettrodi da 4 mm, con spina da KLS Martin
80-332-03-04	1	Electrode neutre en caoutchouc, 8 x 16 cm, avec câble de raccordement de 4 m	Elettrodo neutro di gomma, 8 x 16 cm, cavo di connessione di 4 m
80-372-00-04	1	Bande auto-adhésive, 90 cm	Nastro tessile auto-adesivo, 90 cm
80-505-00-04	1	Tampon de nettoyage pour électrodes, emballage stérile, UC = 100 pièces	Tampone di pulizia per elettrodi, imballaggio sterile, UV = 100 pezzi
80-511-04-04	1	Electrode lancette, coudée	Elettrodo a lancetta, angolato
80-515-04-04	1	Electrode couteau	Elettrodo a bisturi
80-520-04-04	1	Electrode aiguille	Elettrodo ad ago
80-562-04-04	1	Electrode boule, Ø 4 mm	Elettrodo a sfera, Ø 4 mm

80-150-00-04		Zubehörsatz bipolar für minicutter/ ME 102	Accessory set bipolar for miniCutter/ME 102	Juego de accesorios bipolar para miniCutter/ME 102
80-287-53-04	1	Anschlusskabel für bipolare Pinzetten	Connection cable for bipolar forceps	Cable de conexión para pinzas bipolares
80-924-16-04	1	Bipolare Pinzette, gerade, stumpf, 16 cm/6 1/4"	Bipolar forceps, straight, blunt, 16 cm/6 1/4"	Pinza bipolar, recta, roma, 16 cm/6 1/4"
80-945-20-04	1	Bipolare Pinzette, bajonettförmig, stumpf, 20 cm/8"	Bipolar forceps, bayonet-shaped, blunt, 20 cm/8"	Pinza bipolar, en forma bayoneta, roma, 20 cm/8"
80-925-16-04	1	Bipolare Pinzette, abgewinkelt, stumpf, 16 cm/6 1/4"	Bipolar forceps, angled, blunt, 16 cm/6 1/4"	Pinza bipolar, acodada, roma, 16 cm/6 1/4"
80-925-20-04	1	Bipolare Pinzette, abgewinkelt, stumpf, 20 cm/8"	Bipolar forceps, angled, blunt, 20 cm/8"	Pinza bipolar, acodada, roma, 20 cm/8"
80-924-20-04	1	Bipolare Pinzette, gerade, stumpf, 20 cm/8"	Bipolar forceps, straight, blunt, 20 cm/8"	Pinza bipolar, recta, roma, 20 cm/8"

80-150-01-04		Zubehörsatz bipolar mit non-Stick-red-Pinzetten für Minicutter/ ME 102	Set bipolar accessories with nonStick red forceps for miniCutter/ME 102	Juego de accesorios bipolar con pinzas bipolares nonStick red miniCutter/ME 102
80-287-53-04	1	Anschlusskabel für bipolare Pinzetten	Connection cable for bipolar forceps	Cable de conexión para pinzas bipolares
80-986-17-04	1	Bipolare Pinzette, nonStick red, gerade, stumpf, 16 cm/6 1/4"	Bipolar forceps, nonStick red, straight, blunt, 16 cm/6 1/4"	Pinza bipolar, nonStick red, recta, roma, 16 cm/6 1/4"
80-992-20-04	1	Bipolare Pinzette, nonStick red, bajonettförmig, stumpf, 20 cm/8"	Bipolar forceps, nonStick red, bayonet-shaped, blunt, 20 cm/8"	Pinza bipolar, nonStick red, en forma bayoneta, roma, 20 cm/8"
80-987-17-04	1	Bipolare Pinzette, nonStick red, abgewinkelt, stumpf, 16 cm/6 1/4"	Bipolar forceps, nonStick red, angled, blunt, 16 cm/6 1/4"	Pinza bipolar, nonStick red, acodada, roma, 16 cm/6 1/4"
80-987-20-04	1	Bipolare Pinzette, nonStick red, abgewinkelt, stumpf, 20 cm/8"	Bipolar forceps, nonStick red, angled, blunt, 20 cm/8"	Pinza bipolar, nonStick red, acodada, roma, 20 cm/8"
80-986-20-04	1	Bipolare Pinzette, nonStick red, gerade, stumpf, 20 cm/8"	Bipolar forceps, nonStick red, straight, blunt, 20 cm/8"	Pinza bipolar, nonStick red, recta, roma, 20 cm/8"



80-150-00-04		Lot d'accessoires bipolaire pour miniCutter/ME 102	Serie di accessori bipolare per miniCutter/ME 102
80-287-53-04	1	Câble de raccordement pour pinces bipolaires	Cavo di connessione per pinze bipolari
80-924-16-04	1	Pince bipolaire, droite, mousse, 16 cm/6 1/4"	Pinza bipolare, retta, smussa, 16 cm/6 1/4"
80-945-20-04	1	Pince bipolaire, en forme baïonnette, mousse, 20 cm/8"	Pinza bipolare, a forma baionetta, smussa, 20 cm/8"
80-925-16-04	1	Pince bipolaire, coudée, mousse, 16 cm/6 1/4"	Pinza bipolare, angolata, smussa, 16 cm/6 1/4"
80-925-20-04	1	Pince bipolaire, coudée, mousse, 20 cm/8"	Pinza bipolare, angolata, smussa, 20 cm/8"
80-924-20-04	1	Pince bipolaire, droite, mousse, 20 cm/8"	Pinza bipolare, retta, smussa, 20 cm/8"

80-150-01-04		Lot d'accessoires bipolaire avec pinces bipolaires nonStick red miniCutter/ME 102	Set bipolar accessories with nonStick red forceps for miniCutter/ME 102
80-287-53-04	1	Câble de raccordement pour pinces bipolaires	Connection cable for bipolar forceps
80-986-17-04	1	Pince bipolaire, nonStick red, droite, mousse, 16 cm/6 1/4"	Bipolar forceps, nonStick red, straight, blunt, 16 cm/6 1/4"
80-992-20-04	1	Pince bipolaire, nonStick red, en forme baïonnette, mousse, 20 cm/8"	Bipolar forceps, nonStick red, bayonet-shaped, blunt, 20 cm/8"
80-987-17-04	1	Pince bipolaire, nonStick red, coudée, mousse, 16 cm/6 1/4"	Bipolar forceps, nonStick red, angled, blunt, 16 cm/6 1/4"
80-987-20-04	1	Pince bipolaire, nonStick red, coudée, mousse, 20 cm/8"	Bipolar forceps, nonStick red, angled, blunt, 20 cm/8"
80-986-20-04	1	Pince bipolaire, nonStick red, droite, mousse, 20 cm/8"	Bipolar forceps, nonStick red, straight, blunt, 20 cm/8"

Weitere Zubehörsets zu verschiedenen Anwendungen finden Sie in der separaten Broschüre sowie auf der Homepage www.klsmartin.com

- Gynäkologie
- Allgemeine Chirurgie
- Herz- und Thoraxchirurgie
- Orthopädie
- Urologie
- Mund-, Kiefer- und Gesichts-Chirurgie
- HNO-Chirurgie
- Plastische Chirurgie
- Neurochirurgie
- Handchirurgie

Encontrará más kits de accesorios para las diferentes aplicaciones en el folleto separado y en el sitio web www.klsmartin.com

- Ginecología
- Cirugía general
- Cirugía cardíaca y torácica
- Ortopedia
- Urología
- Cirugía oral y maxilofacial
- Cirugía ORL
- Cirugía plástica
- Neurocirugía
- Cirugía de mano

Per ulteriori set di accessori relativi ad applicazioni diverse, consultare le brochure separate e la nostra homepage all'indirizzo www.klsmartin.com

- Ginecologia
- Chirurgia generale
- Chirurgia cardiaca e toracica
- Ortopedia
- Urologia
- Chirurgia orale e maxillofacciale.
- Chirurgia ORL
- Chirurgia plastica
- Neurochirurgia
- Chirurgia della mano

Additional accessory kits for various applications can be found in the separate brochures and at www.klsmartin.com

- Gynaecology
- General surgery
- Cardio- and thoracic surgery
- Orthopaedics
- Urology
- Oral and maxillofacial surgery
- ENT surgery
- Plastic surgery
- Neurosurgery
- Handsurgery

De plus amples sets d'accessoires pour différentes applications sont disponibles dans la brochure séparée ainsi que sur le site www.klsmartin.com

- Gynécologie
- Chirurgie générale
- Chirurgie cardiaque et thoracique
- Orthopédie
- Urologie
- Chirurgie orale et maxillofaciale
- Chirurgie ORL
- Chirurgie plastique
- Neurochirurgie
- Chirurgie de la main

Nummern-Index
Index of order numbers
Indice de números de referencia
Index numerique des références de commande
Elenco dei codici

15

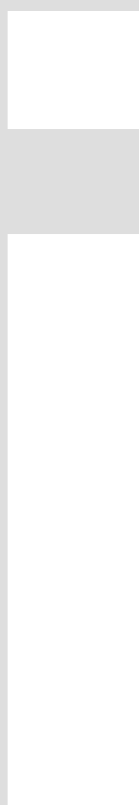

08

08-008-00-03.....	166
08-008-00-04.....	166
08-008-00-05.....	166
08-008-00-06.....	166
08-008-00-08.....	166
08-008-00-14.....	166
08-022-00-19.....	166
08-022-00-21.....	166
08-156-00-11.....	187

55

55-803-70-04.....	45
55-803-71-04.....	102
55-803-73-04.....	102
55-803-74-04.....	103
55-803-75-04.....	103
55-804-25-01.....	74, 75
55-804-42-01.....	74, 75
55-805-28-01.....	74, 75
55-805-45-01.....	74, 75
55-806-02-04.....	74, 75
55-806-07-04.....	74, 75

76

76-100-60-04.....	144, 145
-------------------	----------

79

79-225-02-04.....	144, 145
79-225-03-04.....	144, 145
79-225-06-04.....	144, 145
79-225-07-04.....	144, 145
79-225-08-04.....	144, 145
79-225-09-04.....	144, 145
79-225-10-04.....	144, 145
79-225-11-04.....	144, 145
79-800-02-04.....	144, 145

80

80-006-02-04.....	159
80-006-02-11.....	159
80-008-03-04.....	54, 159
80-008-03-12.....	159
80-010-02-04.....	54, 159
80-010-02-12.....	159
80-040-00-04.....	54
80-040-08-10.....	158
80-040-11-04.....	54, 158
80-040-11-10.....	158
80-040-12-04.....	54, 158
80-040-12-10.....	158
80-041-01-04.....	54
80-042-00-04.....	54, 134, 135, 156
80-042-02-04.....	54, 134, 135, 156
80-042-04-04.....	54, 134, 135, 156
80-042-10-04.....	198
80-042-11-04.....	202, 203
80-042-12-04.....	206, 207
80-042-22-04.....	206, 207
80-042-42-04.....	206, 207
80-043-00-04.....	54, 134, 135, 157

80-043-01-04.....	54, 134, 135, 157
80-043-02-04.....	54, 134, 135, 157
80-043-10-04.....	157
80-044-00-04.....	134, 135, 156
80-047-00-04.....	182, 183
80-048-00-04.....	134, 135, 182, 184, 185
80-048-01-04.....	182, 183
80-048-02-04.....	182, 183
80-048-03-04.....	134, 135, 182, 183
80-048-04-04.....	134, 135, 182, 183
80-048-05-04.....	134, 135, 182, 183
80-048-06-04.....	182, 183
80-060-00-04.....	140, 141
80-060-00-10.....	140, 141
80-060-01-04.....	144, 145
80-060-02-04.....	147
80-060-03-04.....	146
80-060-04-04.....	144, 145
80-060-05-04.....	144, 145
80-060-06-04.....	144, 145
80-061-00-04.....	140, 141
80-061-00-10.....	140, 141
80-062-00-04.....	142, 143
80-062-00-10.....	142, 143
80-062-01-04.....	142, 143
80-062-01-10.....	142, 143
80-062-05-04.....	142, 143
80-062-06-04.....	142, 143
80-065-00-04.....	152, 153
80-070-00-04.....	186, 187
80-070-01-04.....	187
80-070-02-04.....	186
80-070-03-04.....	186
80-070-04-04.....	186
80-070-05-04.....	187
80-070-06-04.....	186
80-091-01-04.....	144, 145
80-091-02-04.....	144, 145
80-093-00-04.....	112, 156
80-093-01-04.....	156
80-093-02-04.....	156
80-094-00-04.....	157
80-094-01-04.....	157
80-094-03-04.....	157
80-103-00-04.....	166
80-105-00-04.....	164
80-105-01-04.....	164
80-105-02-04.....	164
80-105-03-04.....	164
80-106-01-04.....	208, 209
80-107-00-04.....	208, 209
80-108-00-04.....	212, 213
80-108-01-04.....	212, 213
80-108-02-04.....	212, 213
80-108-03-04.....	210, 211
80-108-04-04.....	210, 211
80-108-05-04.....	210, 211
80-120-50-04.....	118
80-120-51-04.....	118
80-122-50-04.....	118

80-122-60-04.....	118
80-140-00-04.....	190
80-140-01-04.....	192, 193
80-150-00-04.....	190, 191, 214, 215
80-150-01-04.....	192, 193, 214, 215
80-160-00-04.....	194, 195
80-160-01-04.....	194, 195
80-160-02-04.....	196, 197
80-181-02-04.....	16, 124, 134, 135, 136, 137, 202, 203, 204, 205
80-181-05-04.....	125
80-181-07-04.....	127
80-181-08-04.....	127
80-181-10-04.....	125, 134, 135, 202, 203, 204, 205
80-181-11-04.....	125, 134, 135
80-181-12-04.....	126, 136, 137
80-181-13-04.....	127, 134, 135, 202, 203, 204, 205
80-181-14-04.....	127, 134, 135
80-181-15-04.....	127, 134, 135, 202, 203, 204, 205
80-181-16-04.....	127, 134, 135
80-181-17-04.....	132
80-181-23-04.....	130, 136, 137, 206
80-181-24-04.....	130, 136, 137, 206
80-181-25-04.....	130, 136, 137, 206
80-181-26-04.....	130
80-181-27-04.....	130
80-181-28-04.....	130
80-181-29-04.....	130
80-181-30-04.....	128, 136, 137, 206
80-181-31-04.....	128
80-181-32-04.....	130
80-181-40-04.....	131
80-181-41-04.....	131
80-181-42-04.....	131
80-181-43-04.....	131
80-181-44-04.....	131
80-181-50-04.....	133
80-181-51-04.....	133, 136, 137
80-181-52-04.....	133, 134, 135, 202, 203, 205, 206, 207
80-181-53-04.....	133, 134, 135, 206
80-181-54-04.....	133, 134, 135
80-181-55-04.....	133, 134, 135, 206
80-181-56-04.....	133, 134, 135
80-181-57-04.....	133, 134, 135
80-181-60-04.....	126
80-181-62-04.....	126
80-181-90-04.....	124, 128, 132, 136, 137
80-210-02-04.....	196, 197
80-210-03-04.....	19, 23
80-210-12-04.....	17, 22, 147
80-210-13-04.....	10, 14, 198, 199
80-210-16-04.....	19, 23
80-210-18-04.....	10, 14, 200, 201
80-210-21-04.....	12, 15

80-210-23-04.....	12, 15
80-213-01-04.....	21, 107
80-214-00-04.....	21
80-214-01-04.....	21
80-214-10-04.....	20, 23
80-214-11-04.....	20, 23, 208
80-214-12-04.....	13, 15, 208, 209
80-214-13-04.....	13, 15, 209
80-217-01-04.....	20, 22, 43, 152, 153, 210, 212
80-217-02-04.....	16, 22, 212
80-217-03-04.....	152, 153
80-217-05-04.....	13, 14, 210, 211, 213
80-217-12-04.....	16, 22
80-217-13-04.....	10, 14, 190, 191, 194, 195, 198, 199, 213
80-217-32-04.....	18
80-219-02-04.....	16, 22
80-219-12-04.....	16, 22
80-219-42-04.....	17, 22
80-220-00-04.....	16, 22, 152, 153, 212
80-220-02-04.....	11, 14, 192, 193, 210, 211, 213
80-220-30-04.....	18
80-220-31-04.....	11, 14
80-220-40-04.....	18
80-220-41-04.....	11, 14
80-221-02-04.....	19, 23, 194, 195
80-225-00-04.....	17, 22
80-225-01-04.....	17, 22
80-225-02-04.....	17, 22
80-227-00-04.....	12, 14
80-227-01-04.....	12, 14
80-227-02-04.....	12, 14
80-251-00-04.....	113
80-260-50-04.....	183, 198, 199, 200, 201, 202, 203, 204, 205, 206, 207
80-280-30-04.....	21, 107, 118
80-285-40-04.....	46, 119
80-285-50-04.....	46, 119
80-285-51-04.....	109
80-285-55-04.....	46, 107, 119
80-286-30-04.....	58, 60, 65, 73, 81, 83, 110, 120
80-286-40-04.....	65, 73, 81, 83, 120
80-286-50-04.....	58, 60, 65, 110, 120
80-286-60-04.....	110, 120
80-286-80-04.....	121
80-286-94-04.....	108, 119
80-286-95-04.....	108, 119
80-286-96-04.....	108, 119
80-287-33-04.....	58, 60, 65, 73, 81, 83, 109, 120, 198, 199, 202, 203, 206, 207
80-287-42-04.....	109, 120
80-287-44-04.....	110, 120

80-287-53-04..... 58, 60, 65, 73, 81,
 109, 120, 190, 191,
 192, 193, 214, 215
 80-287-60-04..... 109, 120
 80-287-70-04..... 110, 120
 80-287-72-04..... 59, 61, 65, 73,
 81, 83, 110, 120
 80-287-80-04..... 121
 80-287-89-04..... 58, 60, 65, 73, 81,
 83, 111, 120, 198,
 199, 200, 201, 203,
 204, 205, 206, 207
 80-287-90-04..... 58, 60, 65, 73,
 81, 83, 111, 120
 80-287-94-04..... 112, 121
 80-287-95-04..... 112, 121
 80-287-96-04..... 112, 121
 80-288-53-04..... 109, 121
 80-288-55-04..... 109, 121
 80-288-57-04..... 110, 111, 121
 80-288-60-04..... 111
 80-288-70-04..... 85
 80-288-72-04..... 85
 80-288-80-04..... 111, 121
 80-289-40-04..... 106, 118, 131,
 206, 207
 80-289-41-04..... 107, 118, 131
 80-289-42-04..... 106, 118
 80-290-40-04..... 107, 118
 80-291-40-04..... 65, 73, 81, 83, 120
 80-293-40-04..... 65, 73, 81, 83, 120
 80-294-40-04..... 52, 54, 55, 136,
 137, 194, 195, 198,
 199, 200, 201, 202,
 203, 204, 205, 206, 207
 80-294-43-04..... 52, 54, 55
 80-294-44-04..... 52, 54, 55, 152,
 153, 194, 195, 196,
 197, 203, 206, 207
 80-310-04-04..... 52, 208, 209
 80-332-03-04..... 50, 54, 210,
 211, 212, 213
 80-342-03-04..... 50, 54, 190, 191,
 192, 193, 194, 195
 80-342-04-04..... 50, 54
 80-342-05-04..... 50, 54
 80-342-06-04..... 51
 80-344-09-04..... 53, 54, 152, 153,
 194, 195, 196, 197,
 198, 199, 200, 201,
 202, 203, 204, 205,
 206, 207
 80-344-11-04..... 53, 54, 55
 80-344-12-04..... 53, 54, 55
 80-370-50-04..... 51, 210, 211,
 212, 213
 80-371-00-04..... 51, 190, 191,
 192, 193
 80-371-01-04..... 51, 190, 191,
 192, 193, 210, 211,
 212, 213

80-371-02-04..... 51
 80-372-00-04..... 51, 194, 195, 210,
 211, 212, 213
 80-408-00-01..... 45
 80-416-00-01..... 45, 190, 191,
 192, 193
 80-444-08-01..... 45, 208, 209
 80-460-04-04..... 44
 80-461-01-04..... 38, 208, 209
 80-461-02-04..... 38, 208, 209
 80-461-03-04..... 38
 80-461-04-04..... 39
 80-461-06-04..... 39
 80-461-07-04..... 39
 80-461-11-04..... 39
 80-461-12-04..... 39, 208, 209
 80-461-13-04..... 39
 80-461-14-04..... 40, 208, 209
 80-461-15-04..... 40, 208, 209
 80-461-16-04..... 40
 80-461-17-04..... 40
 80-461-18-04..... 40
 80-461-19-04..... 40
 80-461-20-04..... 40
 80-461-21-04..... 40
 80-461-22-04..... 41
 80-461-23-04..... 41
 80-461-24-04..... 41
 80-461-31-04..... 41, 208, 209
 80-461-32-04..... 41
 80-461-33-04..... 42
 80-461-34-04..... 42, 208, 209
 80-461-35-04..... 42
 80-461-36-04..... 42
 80-461-37-04..... 42
 80-462-01-04..... 38
 80-462-02-04..... 38
 80-462-11-04..... 39
 80-462-12-04..... 39
 80-462-13-04..... 39
 80-463-01-04..... 38
 80-464-02-04..... 38
 80-464-38-04..... 39
 80-466-01-04..... 38
 80-505-00-04..... 27, 190, 191, 192,
 193, 194, 195, 196,
 197, 198, 199, 200,
 201, 208, 209, 210,
 211, 212, 213
 80-510-04-04..... 29, 190, 191, 192,
 193, 198, 199, 200,
 201, 210, 211,
 212, 213
 80-510-06-04..... 26, 27
 80-510-08-04..... 28, 196, 197
 80-510-12-04..... 32
 80-511-04-04..... 29, 190, 191, 192,
 193, 194, 195, 198,
 199, 200, 201, 210,
 211, 212, 213
 80-511-06-04..... 26

80-515-04-04..... 29, 190, 191, 192,
 193, 194, 195, 198, 199,
 200, 201, 210, 211, 212, 213
 80-515-06-04..... 26, 27
 80-515-08-04..... 28, 196, 197
 80-515-12-04..... 32
 80-515-14-04..... 33
 80-515-16-04..... 33
 80-516-04-04..... 29
 80-516-06-04..... 26
 80-519-04-04..... 29
 80-520-04-04..... 29, 190, 191, 192,
 193, 194, 195, 210,
 211, 212, 213
 80-520-06-04..... 26, 27
 80-520-08-04..... 28, 196, 197
 80-520-09-04..... 28
 80-520-10-04..... 28
 80-521-02-04..... 26
 80-521-04-04..... 26
 80-522-04-04..... 26
 80-525-04-04..... 43
 80-530-04-04..... 42
 80-530-05-04..... 43
 80-531-00-04..... 44
 80-532-00-04..... 44
 80-533-00-04..... 44
 80-533-01-04..... 44
 80-534-06-04..... 34
 80-534-12-04..... 34
 80-540-04-04..... 29, 190, 191, 192,
 193, 210, 211,
 212, 213
 80-540-12-04..... 33
 80-542-04-04..... 29, 190, 191,
 192, 193, 210,
 211, 212, 213
 80-542-06-04..... 27
 80-542-08-04..... 28, 196, 197
 80-542-12-04..... 33
 80-545-04-04..... 29
 80-550-04-04..... 29, 190, 191,
 192, 193
 80-550-06-04..... 27
 80-552-04-04..... 29, 190, 191,
 192, 193
 80-560-04-04..... 29, 190, 191, 192,
 193, 198, 199, 200,
 201, 210, 211,
 212, 213
 80-560-06-04..... 27
 80-562-04-04..... 29, 190, 191,
 192, 193, 194, 195,
 210, 211, 212, 213
 80-562-06-04..... 27
 80-562-08-04..... 28, 196, 197
 80-563-04-04..... 29, 190, 191,
 192, 193
 80-563-05-04..... 43
 80-565-02-04..... 152, 153
 80-565-03-04..... 152, 153

80-570-00-04..... 59, 61
 80-570-04-04..... 29, 190, 191,
 192, 193
 80-570-18-04..... 58
 80-570-21-04..... 58
 80-570-23-04..... 58, 198, 199,
 200, 201, 202,
 203, 204, 205
 80-570-28-04..... 58
 80-571-18-04..... 59
 80-571-21-04..... 59
 80-571-23-04..... 59
 80-571-28-04..... 59
 80-572-04-04..... 29
 80-572-13-04..... 60
 80-572-14-04..... 60
 80-572-17-04..... 60
 80-574-04-04..... 29
 80-580-06-04..... 27
 80-610-10-04..... 36
 80-612-10-04..... 36
 80-630-12-04..... 94, 95
 80-630-15-04..... 94, 95, 96, 97
 80-630-17-04..... 94, 95, 96, 97
 80-630-18-04..... 94, 95, 96, 97
 80-630-34-04..... 96, 97
 80-630-35-04..... 96, 97
 80-630-41-04..... 94, 95
 80-630-42-04..... 96, 97
 80-630-43-04..... 96, 97
 80-630-45-04..... 94, 95, 96, 97
 80-630-50-04..... 98, 99
 80-630-51-04..... 98, 99
 80-630-52-04..... 98, 99
 80-630-53-04..... 98, 99
 80-630-58-04..... 92, 93, 98, 99
 80-630-59-04..... 98, 99
 80-630-83-04..... 98, 99
 80-630-90-04..... 98, 99
 80-630-91-04..... 98, 99
 80-630-92-04..... 98, 99
 80-632-00-04..... 92, 93
 80-632-01-04..... 92, 93
 80-632-18-04..... 92, 93
 80-633-00-04..... 100, 101
 80-633-04-04..... 100, 101
 80-633-05-04..... 100, 101
 80-633-09-04..... 100, 101
 80-633-11-04..... 100, 101
 80-633-12-04..... 100, 101
 80-633-13-04..... 100, 101
 80-650-00-04..... 84
 80-651-00-04..... 84
 80-652-00-04..... 84
 80-674-12-04..... 34
 80-674-13-04..... 34
 80-675-13-04..... 32
 80-676-13-04..... 34
 80-677-12-04..... 32
 80-678-05-04..... 35
 80-678-10-04..... 35

80-678-11-04.....	35
80-680-12-04.....	30
80-681-12-04.....	30
80-682-12-04.....	30
80-683-12-04.....	30
80-684-12-04.....	31
80-685-12-04.....	31
80-686-12-04.....	31
80-690-12-04.....	37
80-691-12-04.....	37
80-692-12-04.....	37
80-693-12-04.....	37
80-694-12-04.....	37
80-695-12-04.....	37
80-790-01-04.....	116
80-790-02-04.....	117
80-793-02-04.....	114
80-794-02-04.....	115
80-795-02-04.....	114
80-795-03-04.....	113
80-795-04-04.....	113
80-795-05-04.....	113
80-796-02-04.....	114
80-796-03-04.....	115
80-797-00-04.....	174
80-797-01-04.....	174
80-797-02-04.....	115
80-800-00-04.....	117
80-811-04-04.....	168, 172, 173, 174, 175, 176
80-811-30-04.....	136, 137, 171, 172, 174, 176, 194, 195, 196, 197, 202
80-811-32-04.....	172, 174, 176
80-811-50-04.....	144, 145, 152, 153, 168, 173, 174, 175, 176, 202, 206, 210, 211
80-812-10-04.....	168, 175, 208, 209
80-821-02-04.....	136, 137, 170, 174, 176, 177
80-821-03-04.....	170, 171, 174, 176, 177
80-821-04-04.....	173, 176
80-821-05-04.....	171, 174, 176
80-823-02-04.....	169, 175, 212, 213
80-824-01-04.....	169
80-824-01-04.....	175
80-825-30-04.....	174, 176
80-830-00-04.....	177, 192, 193
80-830-01-04.....	177, 198, 199, 200, 201, 203, 204, 205
80-830-02-04.....	177, 198, 199, 200, 201, 203, 204, 205, 206, 207
80-830-04-04.....	171, 177
80-830-05-04.....	171, 177
80-900-18-03.....	46
80-900-21-03.....	46
80-900-25-03.....	46
80-901-18-03.....	46
80-901-21-03.....	46

80-902-18-03.....	46
80-902-21-03.....	46
80-902-25-03.....	46
80-910-07-04.....	62
80-910-12-04.....	62
80-910-16-04.....	62
80-910-18-04.....	62
80-910-20-04.....	62
80-910-22-04.....	62
80-911-07-04.....	63
80-911-12-04.....	63
80-911-16-04.....	63
80-911-18-04.....	63
80-911-20-04.....	63
80-924-12-04.....	62
80-924-16-04.....	62, 190, 191, 202, 206, 214, 215
80-924-18-04.....	62
80-924-20-04.....	62, 190, 191, 214, 215
80-924-22-04.....	62
80-924-24-04.....	62
80-924-26-04.....	62
80-924-30-04.....	62
80-925-12-04.....	63
80-925-16-04.....	63, 190, 191, 214, 215
80-925-18-04.....	63
80-925-20-04.....	63, 190, 191, 214, 215
80-925-22-04.....	63
80-931-16-04.....	64
80-931-18-04.....	64
80-931-20-04.....	64
80-931-24-04.....	64
80-934-12-04.....	62
80-934-16-04.....	62
80-934-18-04.....	62
80-934-20-04.....	62
80-934-22-04.....	62
80-934-24-04.....	62
80-934-26-04.....	62
80-934-30-04.....	62
80-935-16-04.....	63
80-935-18-04.....	63
80-935-20-04.....	63
80-935-22-04.....	63
80-935-24-04.....	63
80-945-16-04.....	64
80-945-18-04.....	64
80-945-20-04.....	64, 190, 191, 214, 215
80-945-24-04.....	64
80-948-18-04.....	64
80-948-20-04.....	64
80-948-24-04.....	64
80-948-30-04.....	64
80-950-20-04.....	65
80-951-20-04.....	65
80-971-23-04.....	202
80-975-16-04.....	88

80-975-18-04.....	88
80-975-23-04.....	88, 198, 199, 200, 201, 203, 204, 205
80-975-28-04.....	89
80-976-23-04.....	90
80-977-23-04.....	91
80-978-23-04.....	90
80-981-01-04.....	78
80-981-02-04.....	78
80-981-03-04.....	78
80-981-04-04.....	78
80-981-05-04.....	79
80-981-06-04.....	79
80-981-07-04.....	78
80-981-08-04.....	79
80-982-12-04.....	68
80-982-17-04.....	68
80-982-20-04.....	68
80-982-23-04.....	68
80-983-12-04.....	69
80-983-17-04.....	69
80-984-12-04.....	68
80-984-17-04.....	68
80-984-20-04.....	68
80-985-12-04.....	69
80-985-17-04.....	69
80-985-20-04.....	69
80-986-12-04.....	68
80-986-17-04.....	68, 192, 193, 214, 215
80-986-20-04.....	68, 192, 193, 214, 215
80-986-23-04.....	68
80-987-12-04.....	69
80-987-17-04.....	69, 192, 193, 214, 215
80-987-20-04.....	69, 192, 193, 214, 215
80-987-23-04.....	69
80-988-17-04.....	68
80-988-20-04.....	68
80-988-23-04.....	68
80-988-30-04.....	68
80-989-17-04.....	69
80-989-20-04.....	69
80-989-23-04.....	69
80-989-25-04.....	69
80-989-28-04.....	69
80-989-30-04.....	69
80-990-17-04.....	70
80-990-20-04.....	70
80-990-23-04.....	70
80-990-25-04.....	70
80-991-17-04.....	70
80-991-20-04.....	70
80-991-23-04.....	70
80-991-25-04.....	70
80-992-17-04.....	70
80-992-20-04.....	70, 192, 193, 214, 215

80-992-23-04.....	70
80-992-25-04.....	70
80-993-17-04.....	70
80-993-20-04.....	70
80-993-23-04.....	70
80-993-25-04.....	70
80-994-20-04.....	71
80-994-23-04.....	71
80-994-25-04.....	71
80-995-20-04.....	71
80-995-23-04.....	71
80-995-25-04.....	71
80-996-23-04.....	71
80-996-25-04.....	71
80-997-23-04.....	71
80-997-25-04.....	71
80-998-23-04.....	72
80-999-23-04.....	72
80-999-24-04.....	72

83

83-120-50-04.....	47, 106, 149
83-120-51-04.....	47, 107, 149
83-122-50-04.....	106
83-122-60-04.....	106
83-124-50-04.....	107, 118
83-124-52-04.....	46, 107, 119
83-520-39-04.....	47
83-525-30-04.....	148
83-525-31-04.....	148
83-525-32-04.....	148
83-585-00-04.....	83
83-585-01-04.....	83
83-585-02-04.....	83
83-585-03-04.....	82
83-585-05-04.....	82
83-585-06-04.....	82
83-585-07-04.....	82

92

92-800-74-04.....	133
-------------------	-----

94

94-179-58-04.....	133
94-179-59-04.....	133
94-810-28-04.....	113



Der respektvolle Umgang mit Menschen, Gesellschaft und Umwelt ist für uns selbstverständlich. Die große Mehrzahl unserer Produkte ist auf Wiederverwertbarkeit und jahrelange Nutzung ausgelegt. Dies schont Ressourcen und reduziert das Abfallvolumen. Bei unserer Produktion kommen umweltfreundliche und recyclebare Stoffe zum Einsatz; Energie- und Wasserverbrauch werden überwacht. In unserer größten Produktionsstätte sorgt eine Wärmerückgewinnungsanlage für einen effizienten Energiehaushalt. Diese und viele weitere Maßnahmen sind Zeichen unseres Umwelt-Engagements.

The respectful treatment of people, society and the environment has always been a matter of course to us. By design, most of our products can be recycled and used over many years, thus saving resources and reducing waste. Environmentally-friendly and recyclable materials are used also for our production processes, and energy and water consumption monitoring is a top priority as well. A case in point: our largest manufacturing site includes a heat recovery plant for efficient energy utilization. These and many other measures are clear evidence of our environmental commitment.

Para nosotros, el trato respetuoso de las personas, la sociedad y el medio ambiente se sobreentiende. La gran mayoría de nuestros productos está diseñado para ser utilizado durante años y, finalmente, reciclado. Esto ahorra recursos y reduce el volumen de residuos. En nuestra producción utilizamos materiales reciclables y de bajo impacto ambiental; el consumo de energía y agua es controlado. Un sistema de recuperación de calor proporciona un balance energético eficiente en nuestra mayor sede de producción. Estás y numerosas otras medidas implementadas simbolizan nuestro compromiso medioambiental.

Un comportement respectueux envers les hommes, la société et l'environnement sont pour nous une évidence. La grande majorité de nos produits sont conçus pour être recyclés et utilisés pendant de longues années. Cela ménage les ressources naturelles et réduit le volume des déchets. Dans notre production, nous utilisons des matières écologiques et recyclables; nous avons à l'oeil la consommation d'eau et d'énergie. Dans notre plus grand site de production, les installations de récupération de chaleur assurent un bilan énergétique équilibré. Cette mesure et de nombreuses autres sont le signe de notre engagement en faveur de l'environnement.

Per noi è più che ovvio assumere un atteggiamento rispettoso nei confronti delle persone, della società e dell'ambiente. La maggior parte dei nostri prodotti sono creati con lo scopo della riutilizzabilità e dell'uso pluriennale. Ne consegue un risparmio delle risorse e la riduzione del volume di rifiuti. La nostra produzione prevede l'impiego di materie ecocompatibili e riciclabili, controllando il consumo energetico e idrico. Nel nostro maggiore centro di produzione un impianto di recupero del calore provvede ad un bilancio energetico efficiente. Queste e molte altre misure sono prove del nostro impegno per l'ambiente.

Weitere Informationen entnehmen Sie bitte der separaten Broschüre.

For further information please refer to our separate product brochure.

Encontrará informaciones adicionales en el folleto individual.

Vous trouverez des informations supplémentaires dans la brochure.

Per ulteriori informazioni vedasi il prospetto separato.



KLS Martin Group

KLS Martin Australia Pty Ltd.

Sydney · Australia
Tel.: +61 2 9439 5316
australia@klsmartin.com

Martin Italia S.r.l.

Milan · Italy
Tel. +39 039 605 67 31
italia@klsmartin.com

Gebrüder Martin GmbH & Co. KG

Moscow · Russia
Tel. +7 499 792-76-19
russia@klsmartin.com

KLS Martin do Brasil Ltda.

São Paulo · Brazil
Tel.: +55 11 3554 2299
brazil@klsmartin.com

Nippon Martin K.K.

Tokyo · Japan
Tel. +81 3 3814 1431
nippon@klsmartin.com

Gebrüder Martin GmbH & Co. KG

Dubai · United Arab Emirates
Tel. +971 4 454 16 55
middleeast@klsmartin.com

KLS Martin Medical (Shanghai) International Trading Co., Ltd.

Shanghai · China
Tel. +86 21 5820 6251
china@klsmartin.com

KLS Martin SE Asia Sdn. Bhd.

Penang · Malaysia
Tel.: +604 505 7838
malaysia@klsmartin.com

KLS Martin UK Ltd.

London · United Kingdom
Tel. +44 1189 000 570
uk@klsmartin.com

KLS Martin India Pvt Ltd.

Chennai · India
Tel. +91 44 66 442 300
india@klsmartin.com

Martin Nederland/Marned B.V.

Huizen · The Netherlands
Tel. +31 35 523 45 38
nederland@klsmartin.com

KLS Martin LP

Jacksonville · Florida, USA
Tel. +1 904 641 77 46
usa@klsmartin.com

Bitte laden Sie KLS Martin App Energy Devices herunter!
Die App ist für Android und iOS verfügbar.

Please download KLS Martin App Energy Devices!
The App is available for Android and iOS.

¡Por favor, descarga la Aplicación Energy Devices de KLS Martin!
La Aplicación está disponible para Android y iOS.

Si prega di scaricare l'App Energy Devices di KLS Martin!
L'App è disponibile per Android e iOS.

Veuillez télécharger s.v.p. l'App Energy Devices de KLS Martin!
L'App est disponible pour Android et iOS.



<https://itunes.apple.com/de/app/kls-martin-energy-devices/id1198171415?l=de&ls=1&mt=8>



<https://play.google.com/store/apps/details?id=com.klsmartin.energydevices>

Gebrüder Martin GmbH & Co. KG

A company of the KLS Martin Group

KLS Martin Platz 1 · 78532 Tuttlingen · Germany
P.O. Box 60 · 78501 Tuttlingen · Germany
Tel. +49 7461 706-0 · Fax +49 7461 706-193
info@klsmartin.com · www.klsmartin.com

